

WHELEN[®]

ENGINEERING COMPANY INC.

51 Winthrop Road,
Chester, Connecticut 06412-0684
Phone: (860) 526-9504
Fax: (860) 526-4078

Installation Guide: Edge[®] HC, LC, or SC Ultra Alley Light Kit

Internet: www.whelen.com
Sales e-mail: autosale@whelen.com
Canadian Sales e-mail: autocan@whelen.com
Customer Service e-mail: custserv@whelen.com

WARNING: The strobe light power supply is a high voltage device. Do not remove the strobe tubes or dismantle the strobe lightheads in the system while the unit is in operation. Wait 10 minutes after turning off power to work on the system.

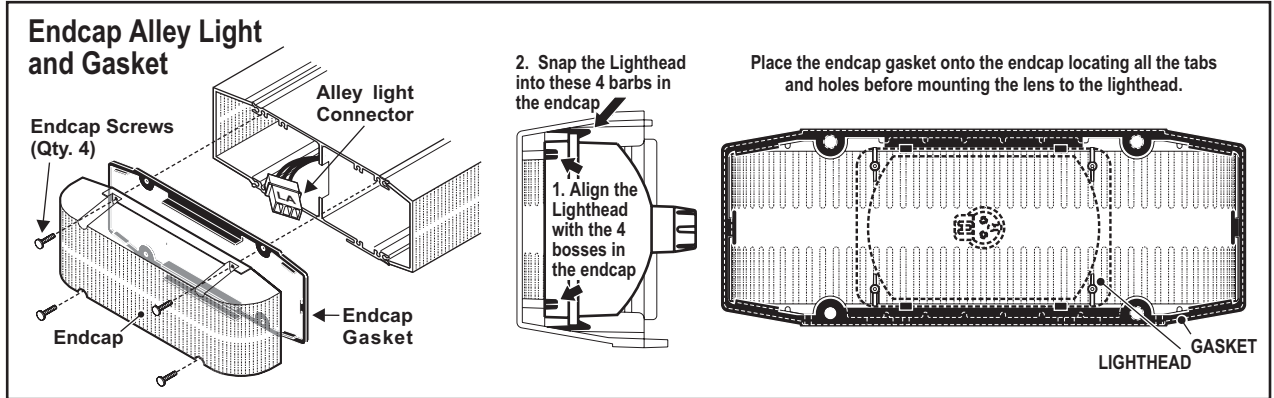

1. Remove the endcaps by first removing the 4 endcap screws and then pulling the endcap off. Install the alley lights onto the endcaps by aligning the reflector of the alley light with the 4 bosses in the endcap, then press the reflector in place until the 4 bars in the endcap snap into place and engage the reflector.
2. Plug the lightheads into the connectors labeled LA and RA and replace the endcaps. Installation is complete. Test the operation of the lightbar before returning it to service.

©2005 Whelen Engineering Company Inc.
Form No.13680B (053107)

For warranty information regarding this product, visit www.whelen.com/warranty

WHELEN[®]

ENGINEERING COMPANY INC.

51 Winthrop Road,
Chester, Connecticut 06412-0684
Phone: (860) 526-9504
Fax: (860) 526-4078

Installation Guide: Edge[®] HC, LC, or SC Ultra Alley Light Kit

Internet: www.whelen.com
Sales e-mail: autosale@whelen.com
Canadian Sales e-mail: autocan@whelen.com
Customer Service e-mail: custserv@whelen.com

WARNING: The strobe light power supply is a high voltage device. Do not remove the strobe tubes or dismantle the strobe lightheads in the system while the unit is in operation. Wait 10 minutes after turning off power to work on the system.

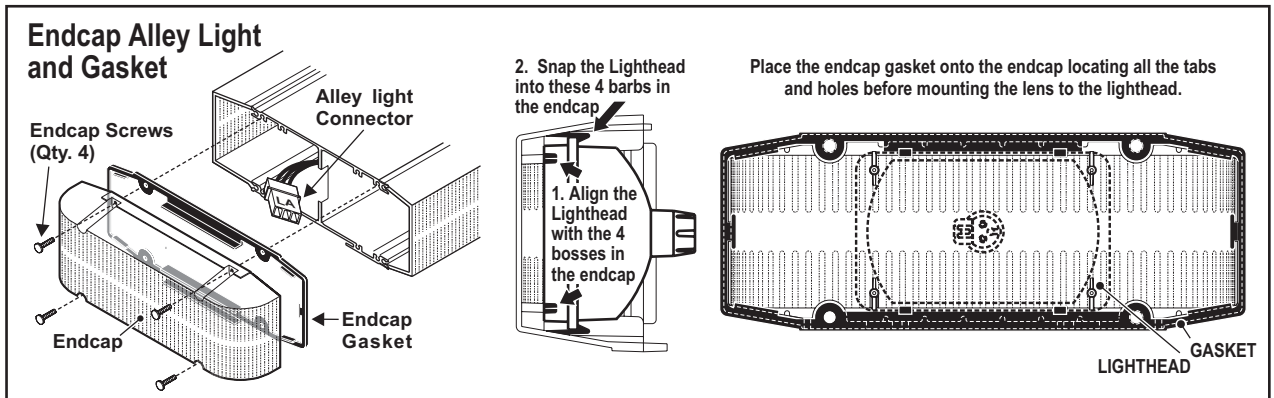

1. Remove the endcaps by first removing the 4 endcap screws and then pulling the endcap off. Install the alley lights onto the endcaps by aligning the reflector of the alley light with the 4 bosses in the endcap, then press the reflector in place until the 4 bars in the endcap snap into place and engage the reflector.
2. Plug the lightheads into the connectors labeled LA and RA and replace the endcaps. Installation is complete. Test the operation of the lightbar before returning it to service.

©2005 Whelen Engineering Company Inc.
Form No.13680B (053107)

For warranty information regarding this product, visit www.whelen.com/warranty