

## WHELEN<sup>®</sup> ENGINEERING COMPANY INC.

51 Winthrop Road  
 Chester, Connecticut 06412-0684  
 Phone: (860) 526-9504  
 Fax: (860) 526-4078  
 Internet: [www.whelen.com](http://www.whelen.com)  
 Sales e-mail: [autosale@whelen.com](mailto:autosale@whelen.com)  
 Canadian Sales e-mail: [autocan@whelen.com](mailto:autocan@whelen.com)  
 Customer Service e-mail: [custserv@whelen.com](mailto:custserv@whelen.com)

### Installation Guide: PCCHD1 Switch Box

**DANGER!** Sirens produces extremely loud emergency warning tones! Exposure to these tones without proper and adequate hearing protection, could cause ear damage and/or hearing loss! The Occupational Safety & Health Administration ([www.osha.gov](http://www.osha.gov)) provides information necessary to determine safe exposure times in Occupational Noise Exposure Section 1910.95. Until you have determined the safe exposure times for your specific application, operators and anyone else in the immediate vicinity should be required to wear an approved hearing protection device. **FAILURE TO FOLLOW THIS RECOMMENDATION COULD CAUSE HEARING LOSS!**

#### Safety First

This document provides all the necessary information to allow your Whelen product to be properly and safely installed. Before beginning the installation and/or operation of your new product, the installation technician and operator must read this manual completely. Important information is contained herein that could prevent serious injury or damage.

- Proper installation of this product requires the installer to have a good understanding of automotive electronics, systems and procedures.
- If mounting this product requires drilling holes, the installer **MUST** be sure that no vehicle components or other vital parts could be damaged by the drilling process. Check both sides of the mounting surface before drilling begins. Also de-burr any holes and remove any metal shards or remnants. Install grommets into all wire passage holes.
- If this manual states that this product may be mounted with suction cups, magnets, tape or Velcro®, clean the mounting surface with a 50/50 mix of isopropyl alcohol and water and dry thoroughly.
- Do not install this product or route any wires in the deployment area of your air bag. Equipment mounted or located in the air bag deployment area will damage or reduce the effectiveness of the air bag, or become a projectile that could cause serious personal injury or death. Refer to your vehicle owner's manual for the air bag deployment area. The User/Installer assumes full responsibility to determine proper mounting location, based on providing ultimate safety to all passengers inside the vehicle.
- For this product to operate at optimum efficiency, a good electrical connection to chassis ground must be made. The recommended procedure requires the product ground wire to be connected directly to the **NEGATIVE (-)** battery post.
- If this product uses a remote device to activate or control this product, make sure this control is located in an area that allows both the vehicle and the control to be operated safely in any driving condition. **DO NOT ATTEMPT TO ACTIVATE OR CONTROL THIS DEVICE IN A HAZARDOUS DRIVING SITUATION.**
- It is recommended that these instructions be stored in a safe place and referred to when performing maintenance and/or reinstallation of this product.
- **FAILURE TO FOLLOW THESE SAFETY PRECAUTIONS AND INSTRUCTIONS COULD RESULT IN DAMAGE TO THE PRODUCT OR VEHICLE AND/OR SERIOUS INJURY TO YOU AND YOUR PASSENGERS!**

**ACTIVATION OF THIS SIREN MAY DAMAGE UNPROTECTED EARS!**



**Wear Protection!**

**CAUTION**

Loud siren noise can cause hearing damage and/or loss. Refer to OSHA Section 1910.95 prior to putting ANY siren into service!

**For warranty information regarding this product, visit [www.whelen.com/warranty](http://www.whelen.com/warranty)**

## Installation:

1. Position the bail strap in the selected mounting location. Using an awl or other suitable tool, scribe the surface where the mounting holes are to be drilled.
2. Drill the mounting holes in the areas scribed. The size of the drill bit should be determined by the size of the mounting hardware (customer supplied) and thickness of the mounting surface.
3. Using your mounting hardware, secure bail strap to mounting location.
4. With the bail strap in place, insert the carriage bolt along with the external tooth lockwasher (supplied) into the assembly hole from the inner side of the bail strap as shown.
5. Place the split lockwasher and the acorn nut on the protruding bolt on the outer side of the bail strap. Loosely secure the acorn nut to the carriage bolt.
6. Now slide the control head onto the carriage bolts. Once it is in the position that the customer has chosen, tighten the acorn nuts until the unit is firmly secured.

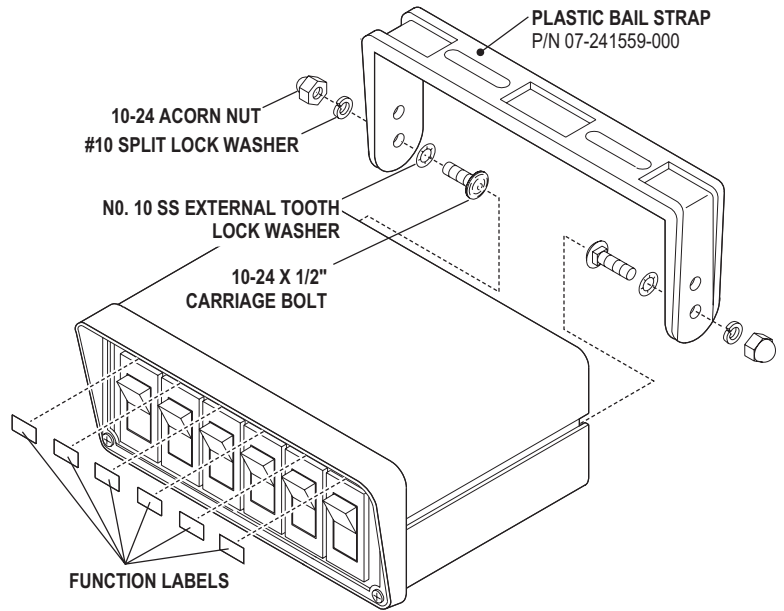

## Backlighting:

1. Plug in the 3-position input connector and extend and connect the BLACK wire to the vehicle's chassis ground.
2. Extend the RED wire to a user supplied fuse box (3 Amp fuse) and connect it to the vehicle accessory switch.

## Wiring:

You may control up to 6 options with a 25 Amp draw each.

Switches 1 through 6 will supply a maximum of 25 Amps each before a switch breaker trips. The total current draw for all 6 switches must not exceed 40 AMPS.

Connect whatever options you wish to control to the terminals in the rear of the unit as shown. Follow the diagram for correct fuse sizes.

**WARNING! All customer supplied wires that connect to the positive terminal of the battery must be sized to supply at least 125% of the maximum operating current and FUSED at the battery to carry that load. DO NOT USE CIRCUIT BREAKERS WITH THIS PRODUCT!**

