

WHELEN[®] ENGINEERING COMPANY INC.

51 Winthrop Road
 Chester, Connecticut 06412-0684
 Phone: (860) 526-9504
 Fax: (860) 526-4078
 Internet: www.whelen.com
 Sales e-mail: autosale@whelen.com
 Canadian Sales e-mail: autocan@whelen.com
 Customer Service e-mail: custserv@whelen.com

Installation Guide:
SA-314 Siren
2002 Chevy Blazer

DANGER! Sirens produces extremely loud emergency warning tones! Exposure to these tones without proper and adequate hearing protection, could cause ear damage and/or hearing loss! The Occupational Safety & Health Administration (www.osha.gov) provides information necessary to determine safe exposure times in Occupational Noise Exposure Section 1910.95. Until you have determined the safe exposure times for your specific application, operators and anyone else in the immediate vicinity should be required to wear an approved hearing protection device. **FAILURE TO FOLLOW THIS RECOMMENDATION COULD CAUSE HEARING LOSS!**

Safety First

This document provides all the necessary information to allow your Whelen product to be properly and safely installed. Before beginning the installation and/or operation of your new product, the installation technician and operator must read this manual completely. Important information is contained herein that could prevent serious injury or damage.

- Proper installation of this product requires the installer to have a good understanding of automotive electronics, systems and procedures.
- If mounting this product requires drilling holes, the installer **MUST** be sure that no vehicle components or other vital parts could be damaged by the drilling process. Check both sides of the mounting surface before drilling begins. Also de-burr any holes and remove any metal shards or remnants. Install grommets into all wire passage holes.
- If this manual states that this product may be mounted with suction cups, magnets, tape or Velcro™, clean the mounting surface with a 50/50 mix of isopropyl alcohol and water and dry thoroughly.
- Do not install this product or route any wires in the deployment area of your air bag. Equipment mounted or located in the air bag deployment area will damage or reduce the effectiveness of the air bag, or become a projectile that could cause serious personal injury or death. Refer to your vehicle owners manual for the air bag deployment area. The User/Installer assumes full responsibility to determine proper mounting location, based on providing ultimate safety to all passengers inside the vehicle.
- For this product to operate at optimum efficiency, a good electrical connection to chassis ground must be made. The recommended procedure requires the product ground wire to be connected directly to the **NEGATIVE (-)** battery post.
- If this product uses a remote device to activate or control this product, make sure this control is located in an area that allows both the vehicle and the control to be operated safely in any driving condition. **DO NOT ATTEMPT TO ACTIVATE OR CONTROL THIS DEVICE IN A HAZARDOUS DRIVING SITUATION.**
- It is recommended that these instructions be stored in a safe place and referred to when performing maintenance and/or reinstallation of this product.
- **FAILURE TO FOLLOW THESE SAFETY PRECAUTIONS AND INSTRUCTIONS COULD RESULT IN DAMAGE TO THE PRODUCT OR VEHICLE AND/OR SERIOUS INJURY TO YOU AND YOUR PASSENGERS!**

ACTIVATION OF THIS SIREN MAY DAMAGE UNPROTECTED EARS!



CAUTION

Loud siren noise can cause hearing damage and/or loss. Refer to OSHA Section 1910.95 prior to putting ANY siren into service!

For warranty information regarding this product, visit www.whelen.com/warranty

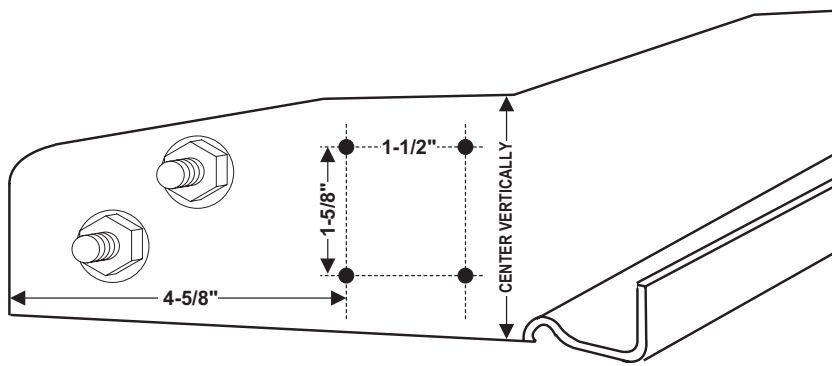

FIG. 2 MOUNTING MEASUREMENTS

NOTE: The support that the bracket will mount to, is shown here separated from the vehicle for illustration purposes only and is **NOT** to be removed from the vehicle for installation.

Installation:

This siren bracket can mount on either the driver or passenger side.

1. Forward of the front tire, find the vehicle support shown in figure 1 that the siren bracket will mount to. Measure 4-5/8" from the inside edge of the support and mark off the first mounting hole as shown. This hole will be about 1/2" from the bottom of the support.
2. Now, mark off the second mounting hole 1-5/8" directly above the first hole. Be sure that these two marks are approximately centered, between the top and bottom of the mounting surface.
3. Mark off the other two mounting holes 1-1/2 inches directly across from the first two as shown in figure 2. You may want to use a level to be sure that these two holes line up with and are square with the first two.
4. Drill the mounting holes with an appropriately sized drill.
5. Attach the siren to the bracket with the supplied mounting hardware.

Note: Be sure the wires from the siren will exit from the bottom of the siren after installation. The wire exit hole is also the sirens drain hole.

6. Now attach the bracket (with siren) to the vehicle using the supplied spacers and mounting hardware as shown and the installation is complete.
7. Extend the white (positive) and black (negative) siren wires to your siren amplifier and connect them as shown in the amplifier's instructions.

Fig. 1. MOUNTING AREA / PASSENGER SIDE

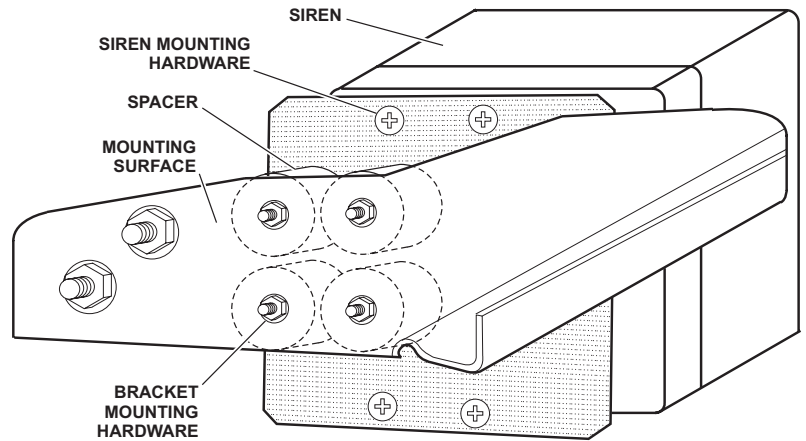
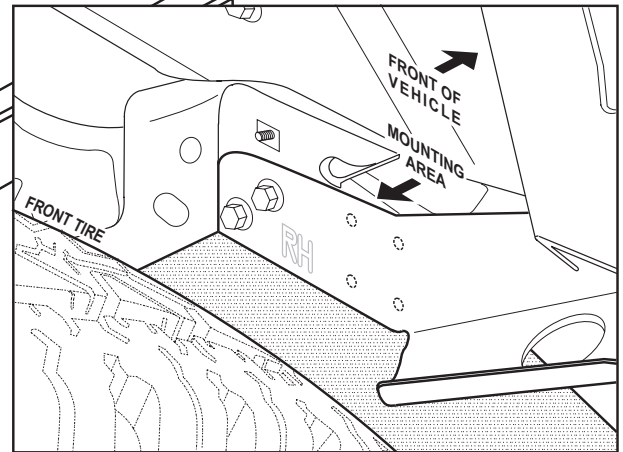
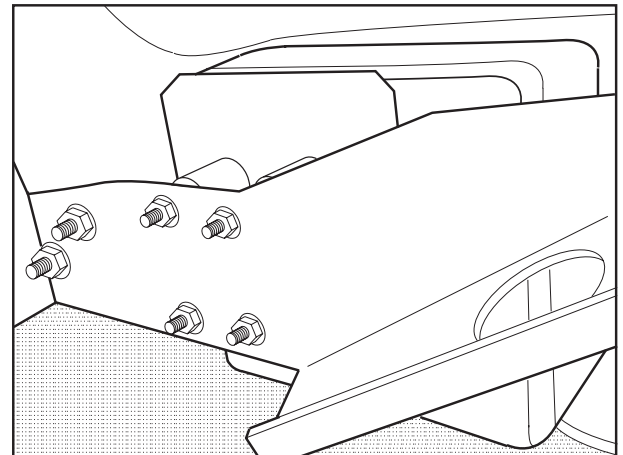

Fig. 3 SIREN & BRACKET MOUNTED TO VEHICLE



ACTIVATION OF THIS SIREN MAY DAMAGE UNPROTECTED EARS!

⚠ CAUTION

Loud siren noise can cause hearing damage and/or loss. Refer to OSHA Section 1910.95 prior to putting ANY siren into service!

Wear Protection!