

WHELEN[®]

ENGINEERING COMPANY INC.

Route 145, Winthrop Road,

Chester, Connecticut 06412

Phone: (860) 526-9504

Fax: (860) 526-4078

Internet: www.whelen.com

Sales e-mail: autosale@whelen.com

Canadian Sales e-mail: autocan@whelen.com

Customer Service e-mail: custserv@whelen.com

Installation Guide VP26HD and VP27HD Strobe Beacons

Safety First

This document provides all the necessary information to allow your Whelen product to be properly and safely installed. Before beginning the installation and/or operation of your new product, the installation technician and operator must read this manual completely. Important information is contained herein that could prevent serious injury or damage.

- **Proper installation of this product requires the installer to have a good understanding of automotive electronics, systems and procedures.**
- **If mounting this product requires drilling holes, the installer MUST be sure that no vehicle components or other vital parts could be damaged by the drilling process. Check both sides of the mounting surface before drilling begins. Also de-burr the holes and remove any metal shards or remnants. Install grommets into all wire passage holes.**
- **If this manual states that this product may be mounted with suction cups, magnets, tape or Velcro™, clean the mounting surface with a 50/50 mix of isopropyl alcohol and water and dry thoroughly.**
- **Do not install this product or route any wires in the deployment area of your air bag. Equipment mounted or located in the air bag deployment area will damage or reduce the effectiveness of the air bag, or become a projectile that could cause serious personal injury or death. Refer to your vehicle owners manual for the air bag deployment area. The User/Installer assumes full responsibility to determine proper mounting location, based on providing ultimate safety to all passengers inside the vehicle.**
- **For this product to operate at optimum efficiency, a good electrical connection to chassis ground must be made. The recommended procedure requires the product ground wire to be connected directly to the NEGATIVE (-) battery post (this does not include products that use cigar power cords).**
- **If this product uses a remote device for activation or control, make sure that this device is located in an area that allows both the vehicle and the device to be operated safely in any driving condition.**
- **Do not attempt to activate or control this device in a hazardous driving situation.**
- **This product contains either strobe light(s), halogen light(s), high-intensity LEDs or a combination of these lights. Do not stare directly into these lights. Momentary blindness and/or eye damage could result.**
- **Use only soap and water to clean the outer lens. Use of other chemicals could result in premature lens cracking (crazing) and discoloration. Lenses in this condition have significantly reduced effectiveness and should be replaced immediately. Inspect and operate this product regularly to confirm its proper operation and mounting condition. Do not use a pressure washer to clean this product.**
- **It is recommended that these instructions be stored in a safe place and referred to when performing maintenance and/or reinstallation of this product.**
- **FAILURE TO FOLLOW THESE SAFETY PRECAUTIONS AND INSTRUCTIONS COULD RESULT IN DAMAGE TO THE PRODUCT OR VEHICLE AND/OR SERIOUS INJURY TO YOU AND YOUR PASSENGERS!**

For warranty information regarding this product, visit www.whelen.com/warranty

Introduction: The VP26HD and VP27HD Series Strobe Beacons, features a combination base which may be used for either Flange Mount, 1" (NPT) Pipe Mount, or Permanent Mount. The threading for a 1 inch (NPT) pipe mounting is precast in the die-cast base. Magnetic Mount models are also available.

Installation: FLANGE MOUNT

1. Using the base gasket as a template, mark the 3 mounting holes and wire access hole onto the mounting surface.
2. Drill holes for the three 10 X 5/8" pan head sheet metal mounting screws which are supplied.
3. Drill the wire access hole using a 1/2" drill.

Note: You should also install a rubber grommet in the wire access hole to protect the wires.

4. Place base gasket on mounting surface aligned with the holes on the mounting surface. After connecting the strobe beacon to the power cable, feed the wires through the wire access hole. Place strobe beacon into proper position. Align the three holes in the base with the three mounting holes in the base gasket and mounting surface. Use the three enclosed mounting screws to attach the strobe light securely to the mounting surface.

Installation: PIPE MOUNT

1. Feed power cable through the 1 inch pipe and connect the cable to the wires of the beacon.
2. Screw the strobe beacon onto the 1 inch pipe, taking precaution not to damage the connected power wires.

Removing Dome & Strobe Power Supply Assembly:

IMPORTANT: When removing dome and strobe power supply assembly, be sure to tape or remove any unused wires

1. Remove the polycarbonate optic dome from the base by removing the two base screws (Fig. 1).
2. Remove the 3 screws that hold down the strobe power supply assembly and separate it from the base.
3. Remove the spring clip and insulator (Figs. 3-7 on page 2).

Fig. 1

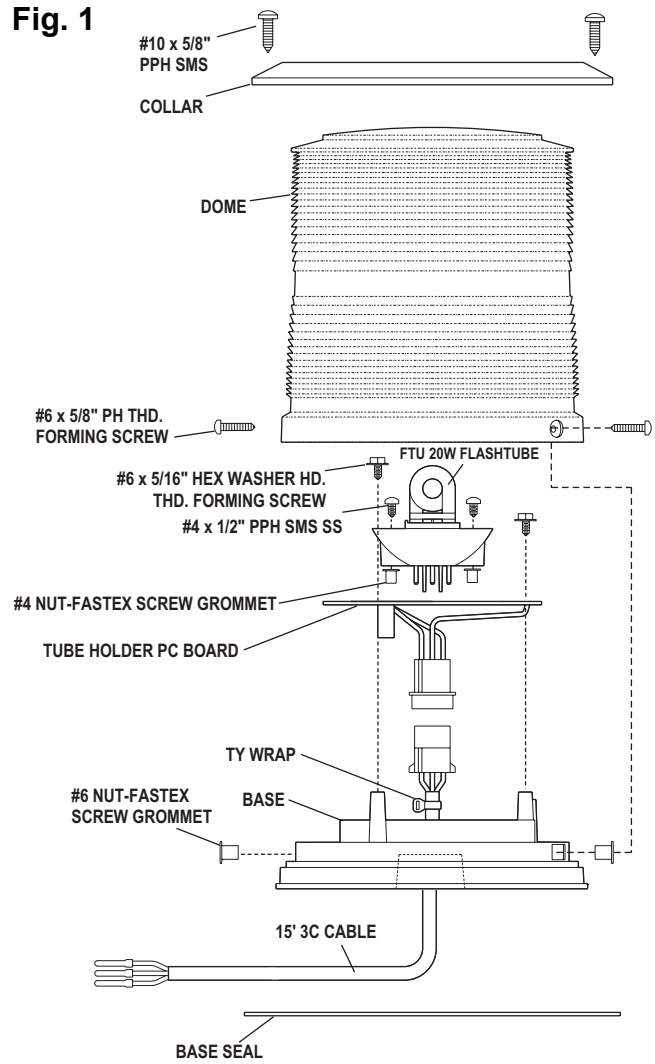

WARNING: The use of any magnetically mounted warning beacon on the outside of a vehicle while in motion is not recommended and is at the sole discretion and risk of the user.

WARNING! All customer supplied wires that connect to the positive terminal of the battery must be sized to supply at least 125% of the maximum operating current and FUSED at the battery to carry that load. DO NOT USE CIRCUIT BREAKERS WITH THIS PRODUCT!

Installation: PERMANENT MOUNT

This mounting of the beacon is a tamper proof way to secure the unit to the mounting surface. The mounting screws are hidden inside the base, and are not accessible unless the strobe beacon is disassembled.

1. Remove the polycarbonate optic dome from the base (See "Removing Dome & Strobe Power Supply Assembly").
2. Locate the four 0.164 inch dimples equally spaced within the perimeter of the die-cast base of the power supply assembly (Fig. 2). Punch these dimples out to create a hole for the mounting screws.
3. Using the base of the power supply assembly as a template mark the four mounting holes on the mounting surface. Mark in the center between the four mounting holes the location of the wire access hole.
4. Drill mounting holes in the mounting surface to fit customer supplied mounting hardware. Also drill a wire access hole using a 1/2 inch drill. (Fig. 2) **NOTE:** You should also install a rubber grommet in the wire access hole to protect the wires.

5. Base gasket will be used between the strobe beacon base and the mounting surface. Cut the gasket along perforation to fit the diameter of the base.
6. After connecting the strobe light beacon to the power cable, feed the wires through the cable access hole and place the base with the gasket on the mounting surface, lining up the mounting holes in the base with the ones in the mounting surface. Secure the strobe light beacon base firmly to the mounting surface with customer supplied hardware.
7. Reassemble the strobe light beacon.

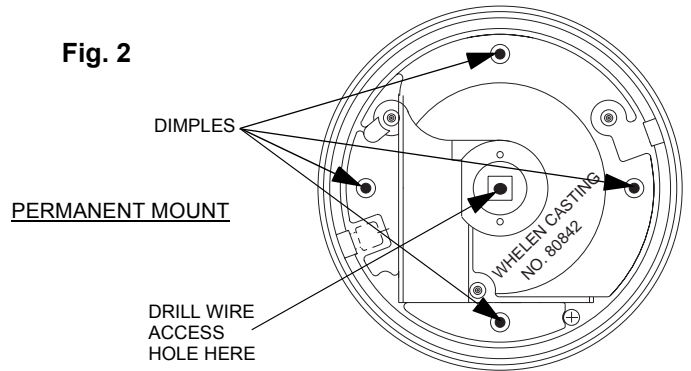

ASSEMBLY INSTRUCTIONS OF STROBE LIGHT POWER SUPPLY TO DIE CAST BASE, TO ENSURE PREVENTION OF AN ELECTRICAL SHORT CIRCUIT BETWEEN THESE TWO PARTS.

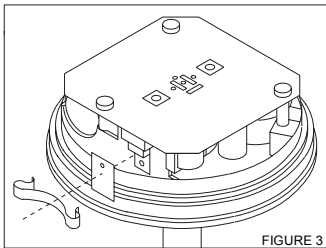

WARNING: The strobe light power supply is a high voltage device. Do not touch or remove strobe tube assembly while unit is in operation. Wait at least 10 minutes after turning off power before starting work or any trouble shooting on the unit.

On this page is described the assembly procedure of the strobe light power supply to the die-cast base. It is extremely important that the assembly steps, as described below, be faithfully followed to insure the proper insulation of the power supply from the base.

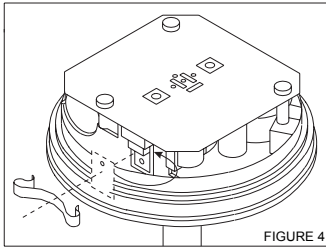

FIGURE 3. Lower the power supply onto the base with the three mounting holes lined up with the holes located on the three mounting studs. During this assembly operation, the transistor on the power supply has to be positioned on the outside of the transistor mounting boss. Secure the power supply to the mounting studs with enclosed self tapping screws.

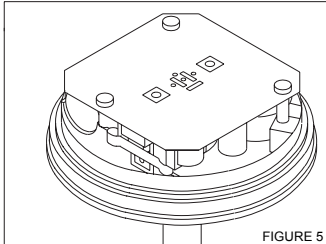

FIGURE 4. Slightly bend the transistor on the power supply away from the transistor mounting boss. Slip the Cho-Therm insulator behind the transistor with the hole directed towards the top (See Figure 6"A"). Position the top of the Cho-Therm insulator against the circuit board of the power supply, making sure that some of it shows below the transistor (See Figure 6"B"). It is important that the transistor does not contact the transistor mounting boss at any place, to prevent a damaging electrical short circuit.

FIGURE 5. Use the transistor spring clip to secure firmly the Cho-Therm insulator and the power supply transistor to the mounting boss of the base. Wrap one end of the clip around one side of the mounting boss, then press the other end in position using needle nose pliers.

