

WHELEN[®]

ENGINEERING COMPANY INC.

Route 145, Winthrop Road,
Chester, Connecticut 06412

Phone: (860) 526-9504

Fax: (860) 526-4078

Internet: www.whelen.com

Sales e-mail: autosale@whelen.com

Canadian Sales e-mail: autocan@whelen.com

Customer Service e-mail: custserv@whelen.com

Replacement Guide: LFL (LC-series) I/O Board

Safety First

This document provides all the necessary information to allow your Whelen product to be properly and safely installed. Before beginning the installation and/or operation of your new product, the installation technician and operator must read this manual completely. Important information is contained herein that could prevent serious injury or damage.

- **Proper installation of this product requires the installer to have a good understanding of automotive electronics, systems and procedures.**
- **If mounting this product requires drilling holes, the installer MUST be sure that no vehicle components or other vital parts could be damaged by the drilling process. Check both sides of the mounting surface before drilling begins. Also de-burr any holes and remove any metal shards or remnants. Install grommets into all wire passage holes.**
- **If this manual states that this product may be mounted with suction cups, magnets, tape or Velcro™, clean the mounting surface with a 50/50 mix of isopropyl alcohol and water and dry thoroughly.**
- **Do not install this product or route any wires in the deployment area of your air bag. Equipment mounted or located in the air bag deployment area will damage or reduce the effectiveness of the air bag, or become a projectile that could cause serious personal injury or death. Refer to your vehicle owners manual for the air bag deployment area. The User/Installer assumes full responsibility to determine proper mounting location, based on providing ultimate safety to all passengers inside the vehicle.**
- **For this product to operate at optimum efficiency, a good electrical connection to chassis ground must be made. The recommended procedure requires the product ground wire to be connected directly to the NEGATIVE (-) battery post.**
- **If this product uses a remote device to activate or control this product, make sure that this control is located in an area that allows both the vehicle and the control to be operated safely in any driving condition.**
- **Do not attempt to activate or control this device in a hazardous driving situation.**
- **This product contains either strobe light(s), halogen light(s), high-intensity LEDs or a combination of these lights. Do not stare directly into these lights. Momentary blindness and/or eye damage could result.**
- **Use only soap and water to clean the outer lens. Use of other chemicals could result in premature lens cracking (crazing) and discoloration. Lenses in this condition have significantly reduced effectiveness and should be replaced immediately. Inspect and operate this product regularly to confirm its proper operation and mounting condition. Do not use a pressure washer to clean this product.**
- **It is recommended that these instructions be stored in a safe place and referred to when performing maintenance and/or reinstallation of this product.**
- **FAILURE TO FOLLOW THESE SAFETY PRECAUTIONS AND INSTRUCTIONS COULD RESULT IN DAMAGE TO THE PRODUCT OR VEHICLE AND/OR SERIOUS INJURY TO YOU AND YOUR PASSENGERS!**

For warranty information regarding this product, visit www.whelen.com/warranty

Opening the Lightbar

WARNING! Disconnect both battery terminals before proceeding!

- Using a Torx™ head screwdriver, remove the 4 endcap screws from each endcap. Remove the endcaps and gasket from the extrusion.

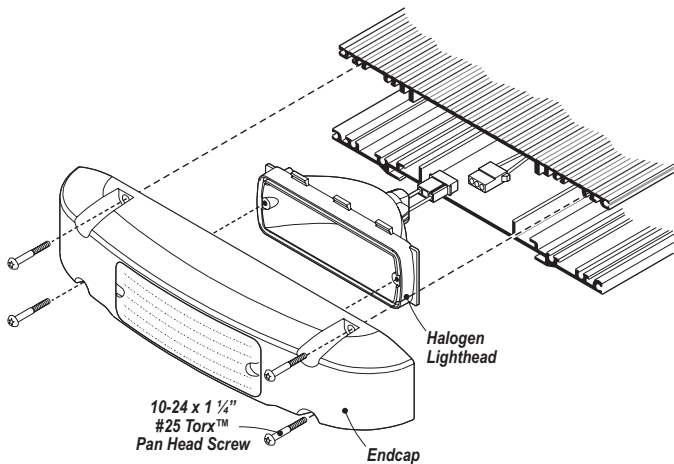

- Remove all lenses and dividers. **Note the location of each lens and divider so that each may be returned to their original location.**
- Slide the 4 corner strobes out of the extrusion.
- Using a Torx™ head screwdriver, remove the 4 screws located on the top of the lightbar extrusion. Remove the top of the extrusion from the lightbar.

Replacing I/O Boards with Grey Main Voltage Connectors.

- Record the location of where each connector plugs into the I/O board. Beginning with the main voltage cables, unplug each connector from the I/O board.

Note: If old I/O board has a personality module installed, this must be removed and transferred onto the new I/O board! Do NOT install the provided jumper onto this type of board.

- Locate and remove the 5 Phillips-head screws that secure the I/O board to its mounting plate. Carefully lift the I/O board up and away from the mounting plate. **Remnants of insulating material may remain on the mounting plate after the board has been removed. These remnants must be completely removed from the mounting plate prior to installation of the new I/O board.**
- Install the new I/O board onto the mounting plate using the original mounting hardware.
- Return all the connectors to their original location.
- Re-assemble the lightbar and reconnect the vehicle battery. Test the lightbar for proper operation. If the lightbar does not operate correctly, contact Whelen technical support.

Replacing I/O Boards with Red & Black Main Voltage Connectors.

- Follow steps 1, 2 & 3 from the previous section.

Note: If old I/O board has a personality module installed, this must be removed and transferred onto the new I/O board! If no module was present, install the provided jumper as shown.

- Separate the RED and BLACK connectors from each other. This can be accomplished by prying them apart using a small flat blade screwdriver.

- To remove the crimped terminal from the plastic connector housing, a flat metal retaining blade must be pressed down. With the connector housing intact, this can be an awkward procedure. The procedure is much easier if the connector is broken in such a way that the retaining blade is completely exposed. With the blade depressed, pull on the cable for removal from the connector.

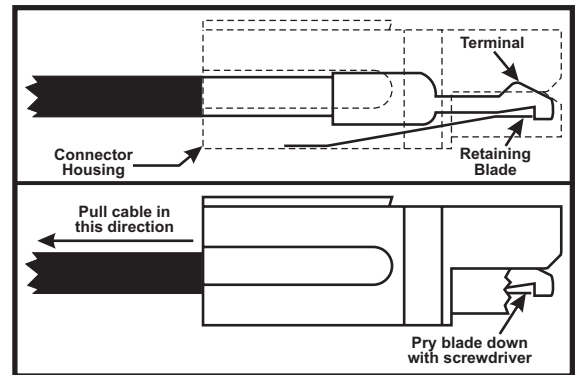

- Locate the new connector housing provided. Insert the RED (Positive) and BLACK (Ground) cables into the connector housing as shown, noting the orientation of the terminals and the housing. Insert the cables until the lip cable terminal is beyond the edge of the retaining blade. A firm pull on the cables will confirm proper installation.

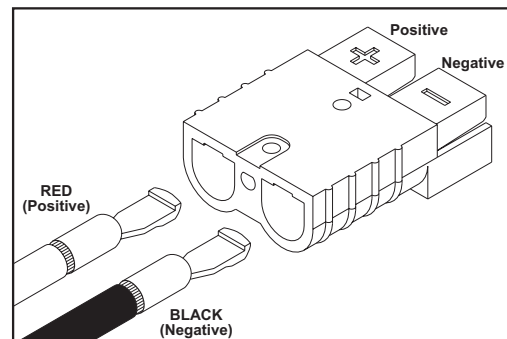

IMPORTANT! The Positive and Negative main voltage cables connect to the new circuit board in different locations than the previously used board. Pay strict attention to the polarity of these connections!

- Install the new connector assembly onto the new circuit board. As shown, align the connector with the power cable contacts. Insert the connector assembly onto the circuit board contacts until it is fully seated.
- If the old I/O board was not equipped with a personality module, a jumper (included) must be installed at the location shown.

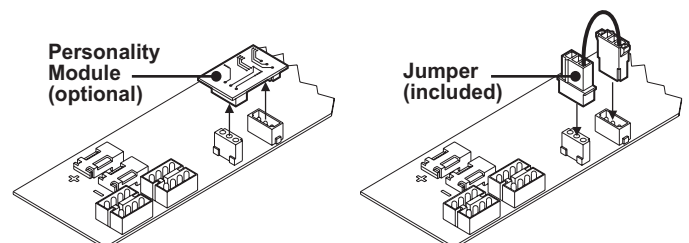

- Re-assemble the lightbar and reconnect the vehicle battery. Test the lightbar for proper operation. If the lightbar does not operate correctly, contact Whelen technical support.