

WHELEN[®]

ENGINEERING COMPANY INC.

51 Winthrop Road
 Chester, Connecticut 06412-0684
 Phone: (860) 526-9504
 Fax: (860) 526-4078
 Internet: www.whelen.com
 Sales e-mail: autosale@whelen.com
 Canadian Sales e-mail: autocan@whelen.com
 Customer Service e-mail: custserv@whelen.com

Installation Guide: Model ALPHA22M Remote Siren Amplifier

DANGER! Sirens produces extremely loud emergency warning tones! Exposure to these tones without proper and adequate hearing protection, could cause ear damage and/or hearing loss! The Occupational Safety & Health Administration (www.osha.gov) provides information necessary to determine safe exposure times in Occupational Noise Exposure Section 1910.95. Until you have determined the safe exposure times for your specific application, operators and anyone else in the immediate vicinity should be required to wear an approved hearing protection device. **FAILURE TO FOLLOW THIS RECOMMENDATION COULD CAUSE HEARING LOSS!**

Safety First

This document provides all the necessary information to allow your Whelen product to be properly and safely installed. Before beginning the installation and/or operation of your new product, the installation technician and operator must read this manual completely. Important information is contained herein that could prevent serious injury or damage.

- Proper installation of this product requires the installer to have a good understanding of automotive electronics, systems and procedures.
- If mounting this product requires drilling holes, the installer **MUST** be sure that no vehicle components or other vital parts could be damaged by the drilling process. Check both sides of the mounting surface before drilling begins. Also de-burr any holes and remove any metal shards or remnants. Install grommets into all wire passage holes.
- If this manual states that this product may be mounted with suction cups, magnets, tape or Velcro™, clean the mounting surface with a 50/50 mix of isopropyl alcohol and water and dry thoroughly.
- Do not install this product or route any wires in the deployment area of your air bag. Equipment mounted or located in the air bag deployment area will damage or reduce the effectiveness of the air bag, or become a projectile that could cause serious personal injury or death. Refer to your vehicle owners manual for the air bag deployment area. The User/Installer assumes full responsibility to determine proper mounting location, based on providing ultimate safety to all passengers inside the vehicle.
- For this product to operate at optimum efficiency, a good electrical connection to chassis ground must be made. The recommended procedure requires the product ground wire to be connected directly to the **NEGATIVE (-)** battery post.
- If this product uses a remote device to activate or control this product, make sure this control is located in an area that allows both the vehicle and the control to be operated safely in any driving condition. **DO NOT ATTEMPT TO ACTIVATE OR CONTROL THIS DEVICE IN A HAZARDOUS DRIVING SITUATION.**
- It is recommended that these instructions be stored in a safe place and referred to when performing maintenance and/or reinstallation of this product.
- **FAILURE TO FOLLOW THESE SAFETY PRECAUTIONS AND INSTRUCTIONS COULD RESULT IN DAMAGE TO THE PRODUCT OR VEHICLE AND/OR SERIOUS INJURY TO YOU AND YOUR PASSENGERS!**

**ACTIVATION OF THIS
 SIREN MAY DAMAGE
 UNPROTECTED EARS!**



CAUTION
 Loud siren noise can cause hearing damage and/or loss. Refer to OSHA Section 1910.95 prior to putting ANY siren into service!

For warranty information regarding this product, visit www.whelen.com/warranty

WARNING! If the ALPHA22M is replacing the siren amplifier in an existing siren system, that systems switches MUST be rewired to match the corresponding Alpha switch wiring diagram found in this manual. If the existing system does not use Alpha switches, refer to the wiring information on page 7 to rewire your switches.

Mounting the ALPHA22M

1. Locate a suitable mounting location for the ALPHA22M. The vertical wall between the trunk and the passenger compartment is often a good choice and is the method discussed in this manual.
2. Be sure that the remote amplifier fits properly and does not interfere with any parts of the trunk lid or seat back.
3. Position the remote amplifier on the proposed mounting location. Using an awl or other suitable tool, scribe the mounting surface where the mounting holes are to be drilled.

CAUTION! As mounting the ALPHA22M will require drilling, it is absolutely necessary to make sure that no other vehicle components could be damaged by the drilling process. If any vehicle component could suffer any potential harm, select a different mounting location.

4. Carefully drill the mounting holes using a drill bit sized for a #10 sheet metal screw.
5. Using the supplied #10 x 3/4" sheet metal screws, secure the remote amplifier to the vertical trunk wall.

Wiring the ALPHA22M 16 position connector

Connecting to Power:

1. Extend the RED and BLACK wires through the firewall and into the engine compartment.
2. Follow the factory wiring harness towards your vehicle's battery.

WARNING! All customer supplied wires that connect to the positive terminal of the battery must be sized to supply at least 125% of the maximum operating current and FUSED at the battery to carry that load. DO NOT USE CIRCUIT BREAKERS WITH THIS PRODUCT!

Dip Switch Functions:

Mechanical Siren Mode

Dip Switch 3	Dip Switch 4	Horn Ring Function
ON	ON	Initiate Air Horn with horn ring
ON	OFF	Simulate mechanical siren "brake" with horn ring
OFF	ON	Initiate Manual tone with horn ring
OFF	OFF	INVALID SELECTION - Do Not Use

NOTE - Dip Switch 5 has no function in mechanical siren Mode

Power Call Mode

Dip Switch 3	Worble Override Options
ON	Worble has push-on/push-off override
OFF	Worble has no override

Dip Switch 4	Wail/Worble Override Options
ON	Wail has push-on/push-off Worble override
OFF	Worble has 10-second Worble override

Dip Switch 5	Wail Tone Options
ON	Simulated mechanical tone for Wail
OFF	Normal Wail Tone

3. Connect the RED wire to one end of a user supplied fuse block. Do not connect this unit to the battery yet!
4. Connect the BLACK wire directly to the NEGATIVE battery terminal.

Connecting to your Speaker(s):

1. Route the ORANGE, YELLOW and BROWN wires along the factory wiring harness towards your speaker(s).
2. Connect the ORANGE wire to the POSITIVE (+) terminal on speaker #1. If two speakers (100 watt max. each) are used, connect the YELLOW wire to the POSITIVE (+) terminal on speaker #2.

If only one speaker is being used, the YELLOW wire must be cut flush with its insulation and capped to prevent this wire from shorting to ground.

3. Connect the BROWN wire to the NEGATIVE (-) terminal on speaker #1. If two speakers are used, splice and connect the BROWN wire to the NEGATIVE (-) terminals on speakers #1 and #2.

Wiring the ALPHA22M

The ALPHA22M can operate in two modes:

- **Mechanical Siren-mode (default)**
- **Power Call-mode**

The operating mode is determined by the position of Dip Switch #6. In the default position (mechanical siren-mode) this switch is ON. Moving this switch to the OFF position places the ALPHA22M in Power Call-mode. The remaining 5 dip switches perform different functions in each mode. Additionally, the wiring of the ALPHA22M is different for each mode. Refer to the appropriate section for detailed wiring information.

**Mechanical Siren Mode -
Wiring Diagram using the Alpha 1 switch assembly**

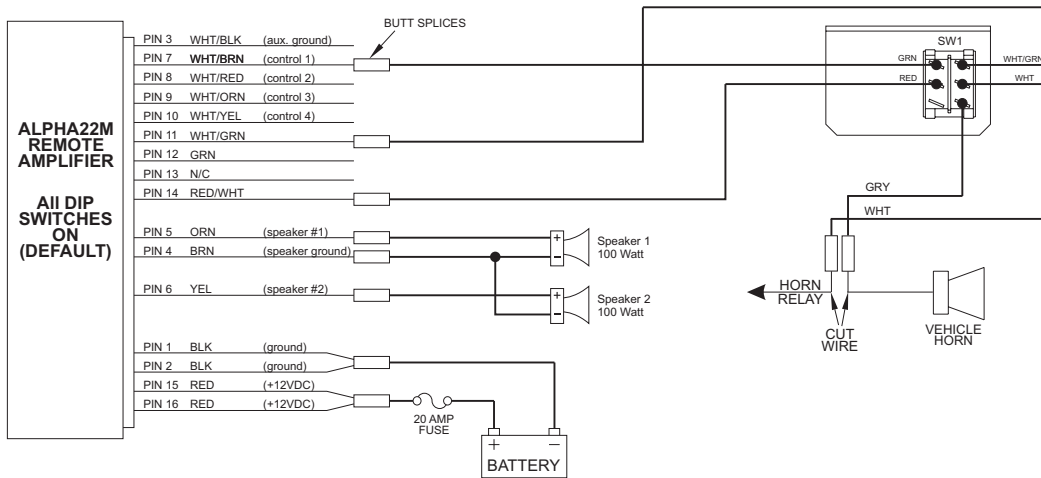

When switch is in this position....	this siren tone is generated....	and the Horn Ring activates....
SW1 ON	Mechanical Wail	Air Horn
SW1 OFF	NO TONE	Vehicle Horn

Wiring Diagram using the Alpha 2 switch assembly

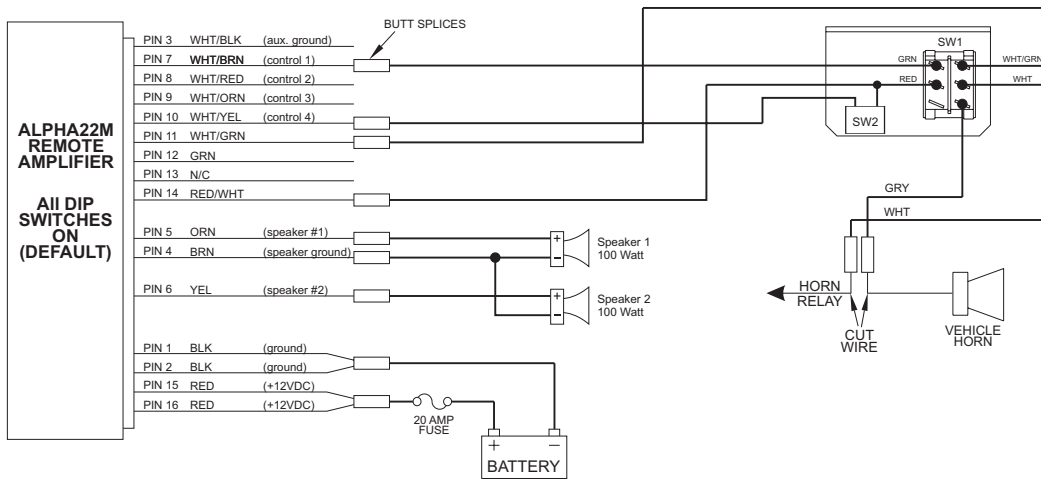

When switches are in this position....	this siren tone is generated....	and pressing SW2 will activate....	and the Horn Ring activates....
SW1 ON	Mechanical Wail	Air Horn	Air Horn
SW1 OFF	NO TONE	Air Horn	Vehicle Horn

Wiring Diagram using the Alpha 3 switch assembly

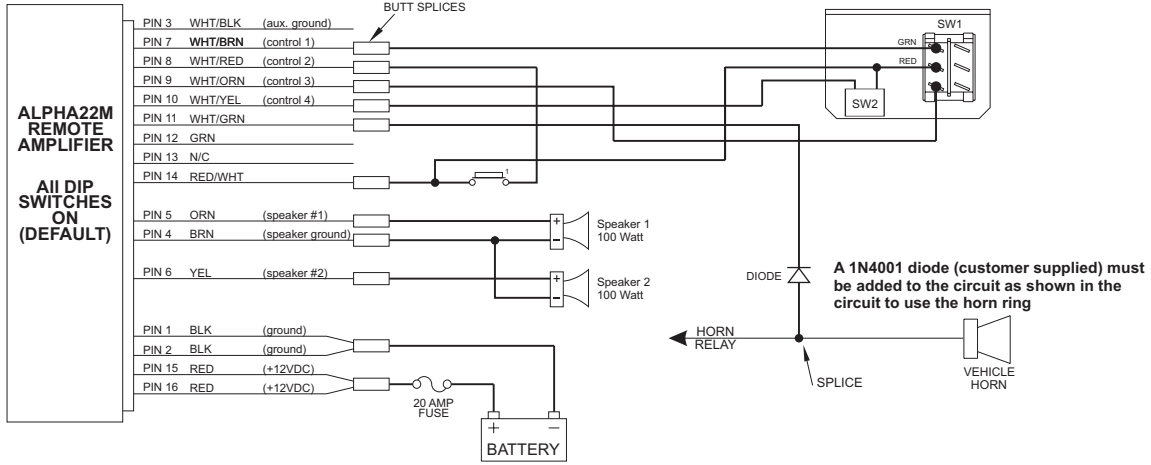

When switches are in this position....	this siren tone is generated....	and pressing SW2 will activate....	and the Horn Ring activates....	and the customer supplied Momentary switch activates....
SW1 TONE 1	Mechanical Wail	Air Horn	Air Horn + Vehicle Horn	Manual override of Mechanical Wail
SW1 OFF	NO TONE	Air Horn	Air Horn + Vehicle Horn	Manual tone activation (with ramp down on release)
SW1 TONE 2	Manual mode*	Air Horn	Air Horn + Vehicle Horn	Manual tone activation (with ramp down on release)

*when the siren is in "Manual mode", no tone is generated until the customer supplied momentary switch is pressed. While this switch is pressed, the siren will produce a tone that will ramp up to a high pitched tone. This tone will be maintained at this pitch until the switch is released. The tone will then ramp down and stop.

Wiring Diagram using the Alpha 4 switch assembly

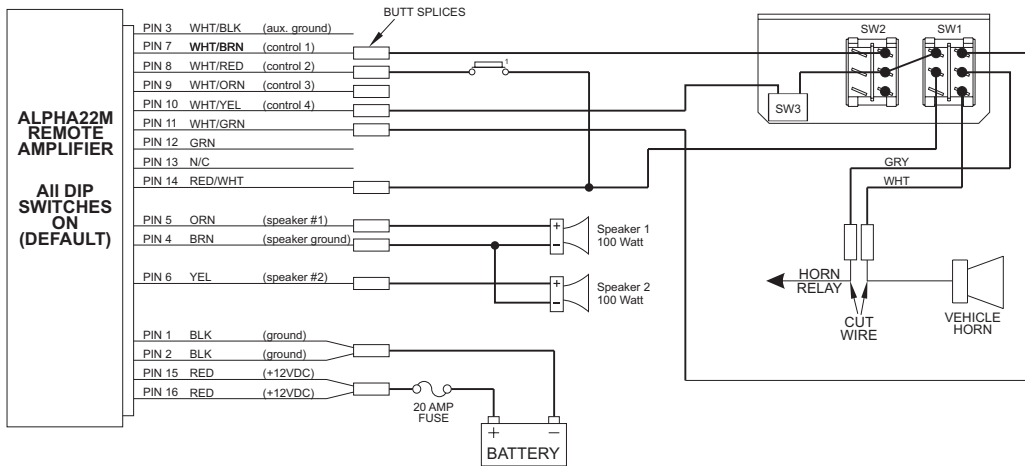

When switches are in this position....	this siren tone is generated....	and pressing SW3 will activate....	and the Horn Ring activates....	and the customer supplied momentary switch activates....	
SW2 TONE 1	SW1 ON	Mechanical Wail	Air Horn	Air Horn	Manual override of Mechanical Wail
	SW1 OFF	NO TONE	NO TONE	Vehicle Horn	Manual tone activation (ramp down on release)
SW2 OFF	SW1 ON	Manual mode*	Air Horn	Air Horn	Manual tone activation (ramp down on release)
	SW1 OFF	NO TONE	NO TONE	Vehicle Horn	Manual tone activation (ramp down on release)
SW2 TONE 2	SW1 ON	Manual mode*	Air Horn	Air Horn	Manual tone activation (ramp down on release)
	SW1 OFF	NO TONE	NO TONE	Vehicle Horn	Manual tone activation (ramp down on release)

*when the siren is in "Manual mode", no tone is generated until the customer supplied momentary switch is pressed. While this switch is pressed, the siren will produce a tone that will ramp up to a high pitched tone. This tone will be maintained at this pitch until the switch is released. The tone will then ramp down and stop.

**Power Call Mode -
Wiring Diagram using the Alpha 1 switch assembly**

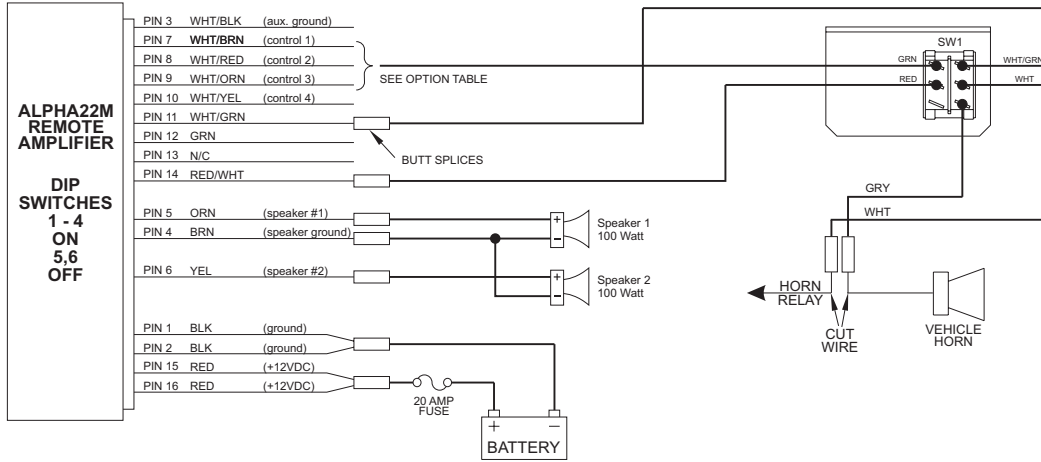

When switch is in this position....	connecting the GREEN to this wire will generate this siren tone....	and the Horn Ring activated override tone is....
SW1 ON	WHT/BRN = Whoop WHT/RED = Warble WHT/ORN = Wail	Air Horn Whoop Warble
SW1 OFF	NO TONE	Vehicle Horn

Wiring Diagram using the Alpha 2 switch assembly

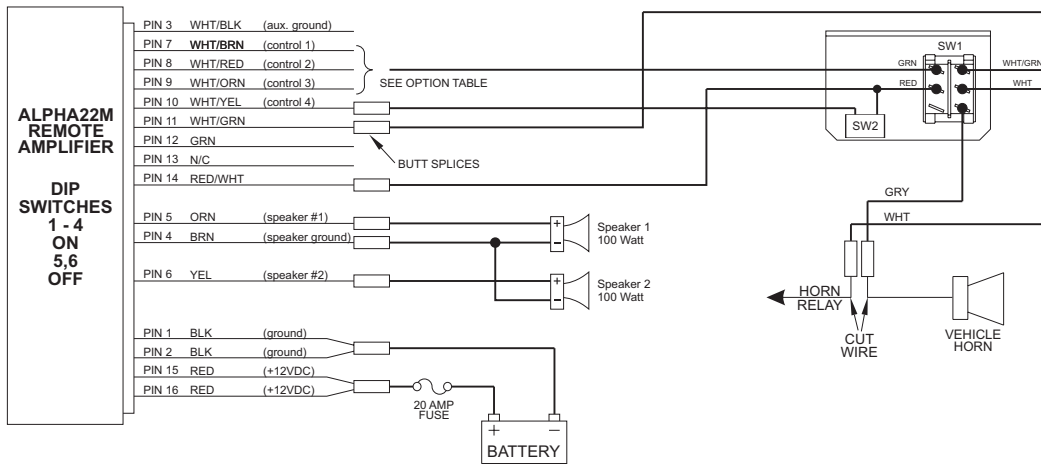

When switch is in this position....	connecting the GREEN to this wire will generate this siren tone....	and pressing SW2 will activate....	and the Horn Ring activated override tone is....
SW1 ON	WHT/BRN = Whoop WHT/RED = Warble WHT/ORN = Wail	Air Horn	Air Horn Whoop Warble
SW1 OFF	NO TONE	Air Horn	Vehicle Horn

Wiring Diagram using the Alpha 3 switch assembly

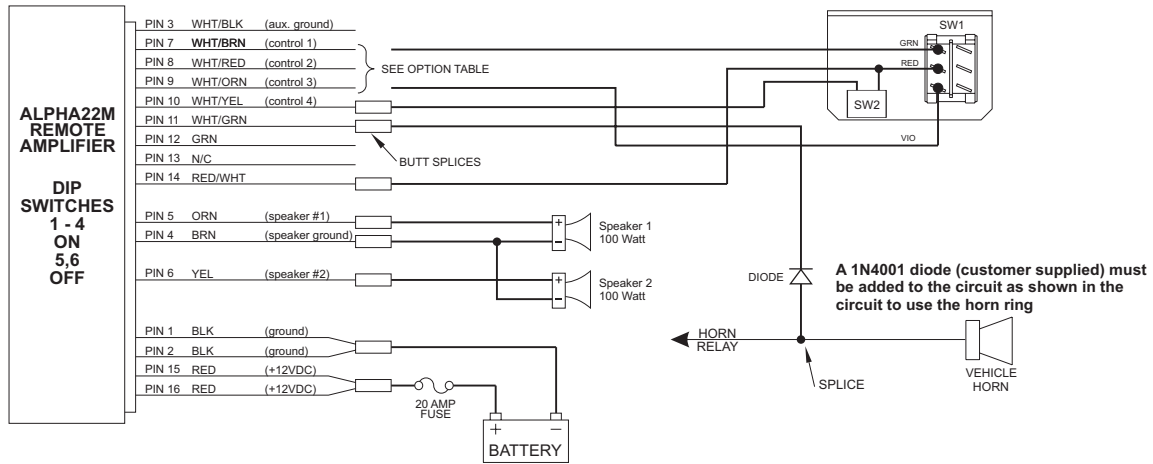

When switch is in this position....	connecting the GREEN wire to this wire will determine Tone 1....	and pressing SW2 will activate....	and the Horn Ring activated override tone is....
SW1 Tone 1	WHT/BRN = Whoop WHT/RED = Warble WHT/ORN = Wail	Air Horn Air Horn Air Horn	Air Horn + Vehicle Horn Whoop + Vehicle Horn Warble + Vehicle Horn
SW1 OFF	NO TONE	Air Horn	Vehicle Horn
When switch is in this position....	connecting the VIOLET wire to this wire will determine Tone 2....	and pressing SW2 will activate....	and the Horn Ring activated override tone is....
SW1 Tone 2	WHT/BRN = Whoop WHT/RED = Warble WHT/ORN = Wail	Air Horn Air Horn Air Horn	Air Horn + Vehicle Horn Whoop + Vehicle Horn Warble + Vehicle Horn

Wiring Diagram using the Alpha 4 switch assembly

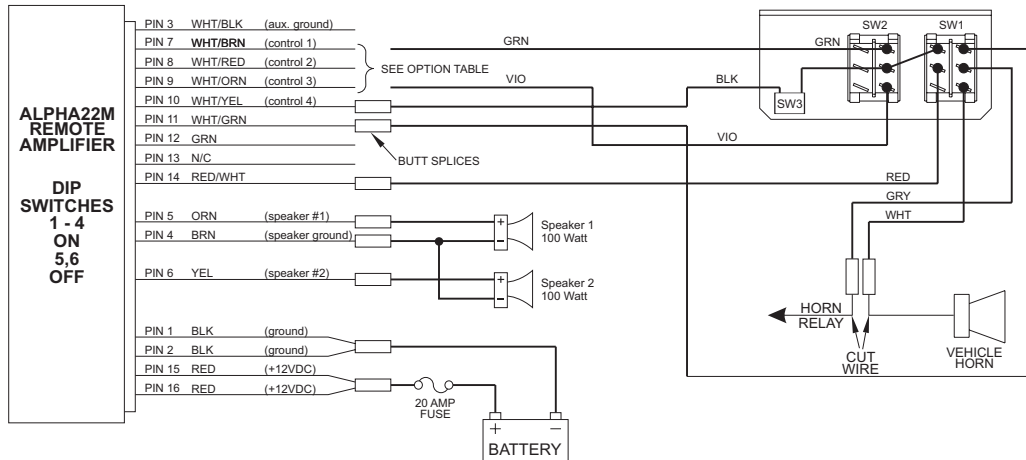

When switches are in this position....	connecting the GREEN wire to this wire will determine Tone 1....	and pressing SW3 will activate....	and the Horn Ring activates....
SW2 TONE 1	SW1 ON	WHT/BRN = Whoop WHT/RED = Warble WHT/ORN = Wail	Air Horn + Vehicle Horn Whoop + Vehicle Horn Warble + Vehicle Horn
	SW1 OFF	NO TONE	Vehicle Horn
SW2 OFF	SW1 ON	NO TONE	Air Horn
	SW1 OFF	NO TONE	Vehicle Horn
When switches are in this position....	connecting the VIOLET wire to this wire will determine Tone 2....	and pressing SW3 will activate....	and the Horn Ring activates....
SW2 TONE 2	SW1 ON	WHT/BRN = Whoop WHT/RED = Warble WHT/ORN = Wail	Air Horn + Vehicle Horn Whoop + Vehicle Horn Warble + Vehicle Horn
	SW1 OFF	NO TONE	Vehicle Horn

The following diagrams provides basic switching information for installations that will not use Alpha switches.

Mechanical Siren Mode -

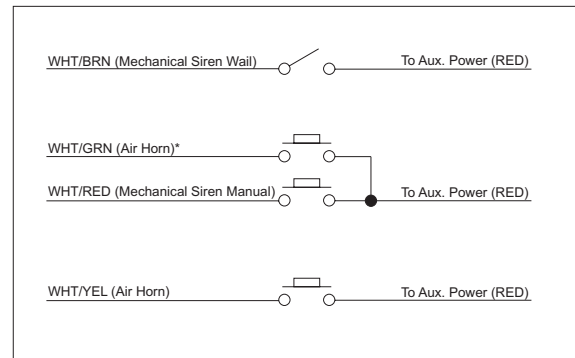
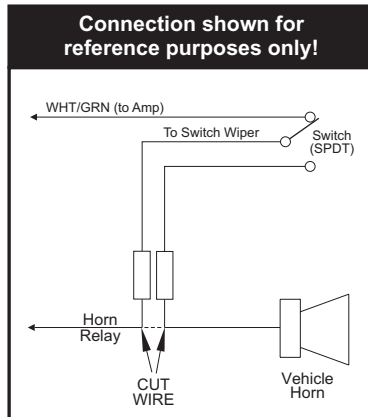

Power Call Mode -

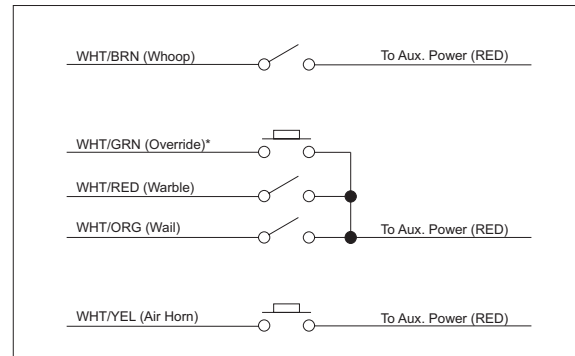

Connecting to your Horn Relay:

1. Locate your vehicle's horn relay. Now locate the wire that connects the vehicle horn to the horn relay and cut this wire.
2. Extend each end of the cut wire (using a minimum 16 gauge wire) to a user supplied SPDT horn transfer switch.
3. Connect the wire coming from the horn relay to the switch "wiper" (see reference diagram above).
4. Connect the wire coming from the horn to one side of the switch (see reference diagram above).
5. Connect the WHITE/GREEN* wire from the 16 position connector to the other side of the switch as shown.

*** The wiring diagrams assume the vehicle uses a positive activated horn ring signal. If this signal is ground activated, use the solid GREEN wire instead of the WHITE/GREEN wire**

The installation of your ALPHA22M series siren amplifier will be complete after the fuse block wire is connected to the POSITIVE (+) terminal of the battery. After this connection has been made, visually inspect the fuse on top of the amplifier and at the battery. If either of these fuses is blown, carefully inspect all of the circuit wires and make sure they are wired correctly. Replace the blown fuses with ones of an identical amp rating as the original. If these fuses blow after installation or activation, contact Whelen Engineering Technical Support.

Specifications

Input Voltage	- 13.5 VDC ±20%
Input Current (Off)	- 0 mA
Input Current (Stand-By)	- 90mA
Input Current (Siren)	- 16 AMPS (w/200W Siren) - 8 AMPS (w/100W Siren)
Output Voltage	- 34 V RMS (MAX.)
Speaker	- 11 ohm (2 100 Watt MAX.)
Output Power@15VDC	- 200 WATTS (MAX.)
Control Voltage	- Input Voltage
Control Current	- 125mA (TYP.)
H/R Voltage	- Input Voltage or Ground
H/R Current	- 15mA (TYP.)
Operating Temp.	- -30° C. to +60° C.
Operating Humidity	- 95% Non Condensing

ACTIVATION OF THIS SIREN MAY DAMAGE UNPROTECTED EARS!



**Wear
Protection!**

⚠ CAUTION

Loud siren noise can cause hearing damage and/or loss. Refer to OSHA Section 1910.95 prior to putting ANY siren into service!

Wire Gauge Calculation Chart

		Wire Gage (AWG)										
		22	20	18	16	14	12	10	8	6	4	2
Current Draw (AMPS)	5	6	9.5	15	24.5	39	62	98	156	248	395	629
	10	3	5	7.5	12	19.5	31	49	78	124	197	314
	15	INS.	3	5	8	13	20.5	32.5	52	82.5	131	209
	20	INS.	INS.	4	6	9.5	15.5	24.5	39	62	98.5	157
	25	INS.	INS.	3	5	8	12.5	19.5	31	49.5	79	125
	30	INS.	INS.	INS.	4	6.5	10.5	16.5	26	41.5	66	104
	35	INS.	INS.	INS.	3.5	5.5	9	14	22.5	35.5	56.5	89.5
	40	INS.	INS.	INS.	3	5	7.5	12.5	19.5	31	49.5	78.5
	45	INS.	INS.	INS.	INS.	4.5	7	11	17.5	27.5	44	69.5
	50	INS.	INS.	INS.	INS.	4	6	10	15.5	25	39.5	63
	55	INS.	INS.	INS.	INS.	3.5	5.5	9	14	22.5	36	57
	60	INS.	INS.	INS.	INS.	3	5	8	13	20.5	33	52.5
	65	INS.	INS.	INS.	INS.	3	5	7.5	12	19	30.5	48.5
	70	INS.	INS.	INS.	INS.	3	4.5	7	11	17.5	28	45
	75	INS.	INS.	INS.	INS.	INS.	4	6.5	10.5	16.5	26.5	42
	80	INS.	INS.	INS.	INS.	INS.	4	6	10	15.5	24.5	39
	85	INS.	INS.	INS.	INS.	INS.	3.5	6	9	14.5	23	37
90	INS.	INS.	INS.	INS.	INS.	3.5	5.5	8.5	14	22	35	
95	INS.	INS.	INS.	INS.	INS.	3.5	5	8	13	21	33	
100	INS.	INS.	INS.	INS.	INS.	3	5	8	12.5	19.5	31.5	

INS. = Insufficient All Distances Shown Are In Feet

To use this chart...

1. Determine the amount of current being drawn through the wire. Locate this number in the vertical left-hand column. If the current value is between adjacent values, use the higher number.
2. Follow this row until the length of the installed wire is shown. If the exact length is between adjacent values, use the higher number. Follow this column upwards to find the recommended size (gage) for this wire.

In the example shown below, the size for a wire with an installed length of 36 feet, through which 22 amps of current will be drawn, must be determined.

A row for 22 amps is not shown, so the row for 25 amps will be used. Follow this row to the right. A column for 36 feet is not shown, so the column for 49.5 feet will be used. Following this column to the top will show that the size of this wire must be at least 6 gage.