

WHELEN[®]

ENGINEERING COMPANY INC.

51 Winthrop Road
 Chester, Connecticut 06412-0684
 Phone: (860) 526-9504
 Fax: (860) 526-2009
 Internet: www.whelen.com
 Sales/Service e-mail: aviation@whelen.com

Installation Guide: Model 70905 ()-series Model 7090501 P/N:01-0770905-01 LED Flashing Anti-Collision Light Assembly



TSO-C96a CLASS I
 APPROVED

The conditions and tests required for TSO approval of this article are minimum performance standards. It is the responsibility of those installing this article either on or within a specific type or class of aircraft to determine that the aircraft installation conditions are within the TSO standards. TSO articles must have separate approval for installation in aircraft. The article may be installed only if performed under 14 CFR part 43 or the applicable airworthiness requirements.

OPERATING INSTRUCTIONS:

Operational Voltage:24 - 32 VDC
Average Input Current:0.45 Amps
Peak Input Current:2.5 Amps @ .25 Seconds

EQUIPMENT LIMITATIONS:

Rotorcraft for which type certificate was applied for after April 1, 1957 to August 11, 1971:

The anti-collision system must produce a minimum of 100 effective candelas in Aviation Red or White, 360° around the vertical axis, 30° above and below the horizontal plane. A single beacon will meet this requirement.

Rotorcraft for which type certificate was applied for after August 11, 1971 to February 5, 1976:

The anti-collision system must produce a minimum of 400 effective candelas in Aviation Red or White, 360° around the vertical axis, 30° above and below the horizontal plane. This beacon does not meet this requirement.

Rotorcraft for which type certificate was applied for after February 5, 1976:

The anti-collision system must produce a minimum of 150 effective candelas in Aviation Red, 360° around the vertical axis, 30° above and below the horizontal plane. A single beacon will meet this requirement.

Certain types of installations may require additional testing.

CONTINUED AIRWORTHINESS: The 70905 series LED anti-collision light assembly is designed with 5 columns consisting of 5 LEDs each, and 5 columns consisting of 4 LEDs each. Should any one LED or any vertical column fail, the unit must be repaired or replaced.

NOTE: To reduce eye strain, use an optical filter such as dark glasses or a blue covering dome during LED inspection. Inspect the lens. Replace if there is any excessive scratching, pitting, discoloration or cracking.

INSTALLATION PROCEDURES: The following information is to assist in the installation of a Whelen LED Flashing Anti-collision Light System.

1. The installation procedure described in the following text will be confined to a single light installation, but is identical for multiple light installations.
2. Prepare the aircraft for means to secure the LED Flashing Anti-collision Light assembly (see reference AC 43.13-2A Chapter 4)
3. 28 VDC (+) and (-) ground leads equipped with an appropriate sized breaker to be supplied to the LED Flashing Anti-collision Light Assembly System. Both leads must be connected by an approved FAA connection.

Insure that the wire leads are all clear of any obstructions and ty-wrap as required.

4. Install the light assembly by securing to aircraft using the appropriate, approved hardware. **Note:** Lens mounting screws installed with 5-7 in./lbs. of torque.
5. Check all avionics systems for interference from this installation.
6. A flight check should be performed by a properly certified pilot.
7. All inverted (bottom) mounted units shall require waterproofing of the mounting hardware. An application of single-part silicone (RTV) or equivalent applied over top of the mounting hardware, after installation, is recommended. Reference page 2 for an illustration. Inverted and/or standard mounted units, when necessary, may require waterproofing around any open area where water could get in. Specifically, the lens to the flasher base assembly, and the flasher base assembly to the aircraft. **Note:** It is permissible to drill a 1/8" drain hole in the center of the lens for bottom mount units.
8. Update aircraft records, complete Form 337 and obtain FAA field approval for installation, as necessary.

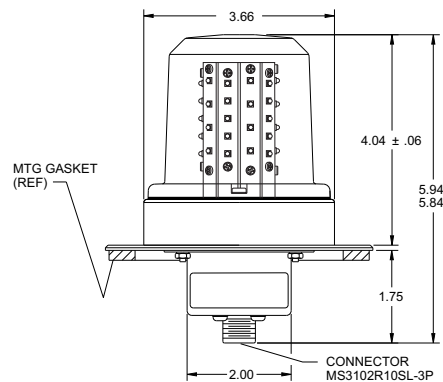
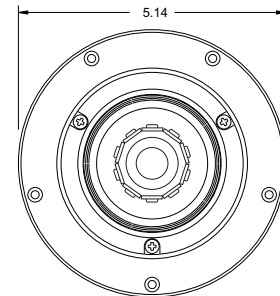

Aviation

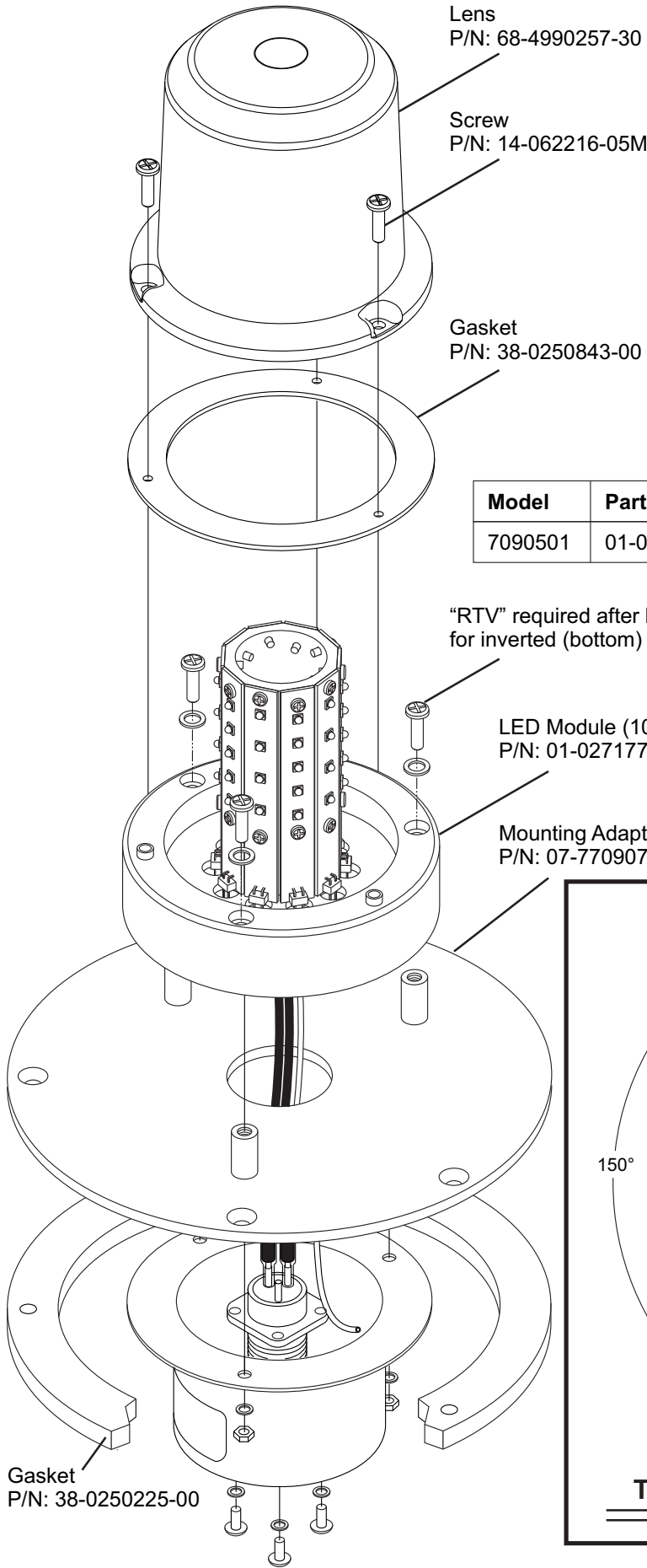

Model	Part Number	Description
7090501	01-0770905-01	28VDC, MS Connector

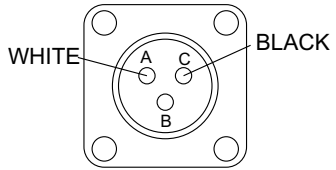

MS CONNECTOR WIRING
(REAR VIEW)

