

WHELEN[®]

ENGINEERING COMPANY INC.

Route 145, Winthrop Road,
Chester, Connecticut 06412
Phone: (860) 526-9504
Fax: (860) 526-4078

Internet: www.whelen.com
Sales e-mail: autosale@whelen.com
Canadian Sales e-mail: autocan@whelen.com
Customer Service e-mail: custserv@whelen.com

Installation Guide 2 Channel/6 Outlet LED Flasher

Safety First

This document provides all the necessary information to allow your Whelen product to be properly and safely installed. Before beginning the installation and/or operation of your new product, the installation technician and operator must read this manual completely. Important information is contained herein that could prevent serious injury or damage.

- Proper installation of this product requires the installer to have a good understanding of automotive electronics, systems and procedures.
- If mounting this product requires drilling holes, the installer **MUST** be sure that no vehicle components or other vital parts could be damaged by the drilling process. Check both sides of the mounting surface before drilling begins. Also de-burr any holes and remove any metal shards or remnants. Install grommets into all wire passage holes.
- If this product is mounted with tape or Velcro™, clean the mounting surface with a 50/50 mix of isopropyl alcohol and water and dry thoroughly.
- Do not install this product or route any wires in the deployment area of your air bag. Equipment mounted or located in the air bag deployment area will damage or reduce the effectiveness of the air bag, or become a projectile that could cause serious personal injury or death. Refer to your vehicle owners manual for the air bag deployment area. The User/Installer assumes full responsibility to determine proper mounting location, based on providing ultimate safety to all passengers inside the vehicle.
- For this product to operate at optimum efficiency, a good electrical connection to chassis ground must be made. The recommended procedure requires the product ground wire to be connected directly to the NEGATIVE (-) battery post.
- If this product uses a remote device to activate or control this product, make sure that this control is located in an area that allows both the vehicle and the control to be operated safely in any driving condition.
- Do not attempt to activate or control this device in a hazardous driving situation.
- It is recommended that these instructions be stored in a safe place and referred to when performing maintenance and/or reinstallation of this product.
- FAILURE TO FOLLOW THESE SAFETY PRECAUTIONS AND INSTRUCTIONS COULD RESULT IN DAMAGE TO THE PRODUCT OR VEHICLE AND/OR SERIOUS INJURY TO YOU AND YOUR PASSENGERS!

©2003 Whelen Engineering Company Inc.
Form No.13855A (031704)

WHELEN[®]

ENGINEERING COMPANY INC.

Route 145, Winthrop Road,
Chester, Connecticut 06412
Phone: (860) 526-9504
Fax: (860) 526-4078

Internet: www.whelen.com
Sales e-mail: autosale@whelen.com
Canadian Sales e-mail: autocan@whelen.com
Customer Service e-mail: custserv@whelen.com

Installation Guide 2 Channel/6 Outlet LED Flasher

Safety First

This document provides all the necessary information to allow your Whelen product to be properly and safely installed. Before beginning the installation and/or operation of your new product, the installation technician and operator must read this manual completely. Important information is contained herein that could prevent serious injury or damage.

- Proper installation of this product requires the installer to have a good understanding of automotive electronics, systems and procedures.
- If mounting this product requires drilling holes, the installer **MUST** be sure that no vehicle components or other vital parts could be damaged by the drilling process. Check both sides of the mounting surface before drilling begins. Also de-burr any holes and remove any metal shards or remnants. Install grommets into all wire passage holes.
- If this product is mounted with tape or Velcro™, clean the mounting surface with a 50/50 mix of isopropyl alcohol and water and dry thoroughly.
- Do not install this product or route any wires in the deployment area of your air bag. Equipment mounted or located in the air bag deployment area will damage or reduce the effectiveness of the air bag, or become a projectile that could cause serious personal injury or death. Refer to your vehicle owners manual for the air bag deployment area. The User/Installer assumes full responsibility to determine proper mounting location, based on providing ultimate safety to all passengers inside the vehicle.
- For this product to operate at optimum efficiency, a good electrical connection to chassis ground must be made. The recommended procedure requires the product ground wire to be connected directly to the NEGATIVE (-) battery post.
- If this product uses a remote device to activate or control this product, make sure that this control is located in an area that allows both the vehicle and the control to be operated safely in any driving condition.
- Do not attempt to activate or control this device in a hazardous driving situation.
- It is recommended that these instructions be stored in a safe place and referred to when performing maintenance and/or reinstallation of this product.
- FAILURE TO FOLLOW THESE SAFETY PRECAUTIONS AND INSTRUCTIONS COULD RESULT IN DAMAGE TO THE PRODUCT OR VEHICLE AND/OR SERIOUS INJURY TO YOU AND YOUR PASSENGERS!

©2003 Whelen Engineering Company Inc.
Form No.13855A (031703)

This product is designed for use with 12 volt LED lighthead. Do not exceed 5 Amps total current draw per channel.

Mounting - Position the flasher unit onto its proposed mounting surface. Do not select a location where it will be exposed to water or extreme heat. Using the unit as a template, mark the area where the mounting holes are to be drilled. Secure the unit using appropriately sized hardware.

Wiring - As seen from the rear of the 16-position connector, the wire color/functions are as shown.

1. Extend the RED wire to a Single Pole/Single Throw switch. From this switch, extend a wire to +12VDC. Fuse this wire @ 15 Amps.

All customer supplied wires that connect to the Positive (+) battery terminal must be sized to supply at least 125% of the maximum operating current and fused "at the battery" to carry that load.

2. Extend the BLK wire to chassis ground.
3. Extend the WHT/VIO wire to a user controlled momentary switch. From this switch extend a wire to +12VDC. Fuse this wire @ 1 Amp.
4. If other flashers are to be synchronized, butt splice the GRY wires together (refer to the Sync section for more information). If Sync is not desired, cut and cap this wire.

Synchronizing - To sync two or more units, configure all flashers to display the same Phase 1 pattern. When activated, the patterns displayed will be synchronized. To configure specific lighthead to alternate their patterns with other lighthead, advance the pattern of the desired flasher(s) to the Phase 2 mode of the current pattern (see Sync pattern table for pattern list).

This flasher has 4 unique modes for each of the 5 available patterns; Alternating Phase 1, Alternating Phase 2, Simultaneous Phase 1 and Simultaneous Phase 2. In Alternating mode, even numbered outlets will alternate with odd numbered outlets. In Simultaneous mode, all outlets will flash simultaneously.

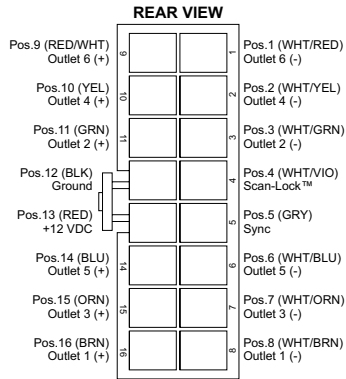

This product is designed for use with 12 volt LED lighthead. Do not exceed 5 Amps total current draw per channel.

Mounting - Position the flasher unit onto its proposed mounting surface. Do not select a location where it will be exposed to water or extreme heat. Using the unit as a template, mark the area where the mounting holes are to be drilled. Secure the unit using appropriately sized hardware.

Wiring - As seen from the rear of the 16-position connector, the wire color/functions are as shown.

1. Extend the RED wire to a Single Pole/Single Throw switch. From this switch, extend a wire to +12VDC. Fuse this wire @ 15 Amps.

All customer supplied wires that connect to the Positive (+) battery terminal must be sized to supply at least 125% of the maximum operating current and fused "at the battery" to carry that load.

2. Extend the BLK wire to chassis ground.
3. Extend the WHT/VIO wire to a user controlled momentary switch. From this switch extend a wire to +12VDC. Fuse this wire @ 1 Amp.
4. If other flashers are to be synchronized, butt splice the GRY wires together (refer to the Sync section for more information). If Sync is not desired, cut and cap this wire.

Synchronizing - To sync two or more units, configure all flashers to display the same Phase 1 pattern. When activated, the patterns displayed will be synchronized. To configure specific lighthead to alternate their patterns with other lighthead, advance the pattern of the desired flasher(s) to the Phase 2 mode of the current pattern (see Sync pattern table for pattern list).

This flasher has 4 unique modes for each of the 5 available patterns; Alternating Phase 1, Alternating Phase 2, Simultaneous Phase 1 and Simultaneous Phase 2. In Alternating mode, even numbered outlets will alternate with odd numbered outlets. In Simultaneous mode, all outlets will flash simultaneously.

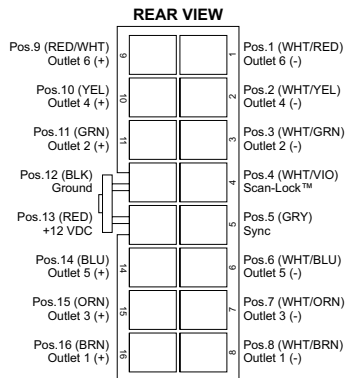

The diagram below shows the relationship between two flashers. Keep in mind that all flashers connected by the Grey wire must be configured to flash the same pattern (as shown, both flashers are displaying Signal Alert™).

Scan-Lock™ / Pattern Selection - To advance to the next pattern, press the momentary switch (step 3) for less than 1 second and release. Hold this switch for more than 1 second to cycle backwards through the patterns.

To reset to the Factory Default Pattern - Turn off power to the flasher. While holding down the momentary switch, turn the flasher on. Continue to hold the switch for 5 seconds.

Pattern Table -

- | | |
|----------------------------------|----------------------------------|
| 1. SignalAlert™ (Alt. / Phase 1) | 11. DoubleFlash (Sim. / Phase 1) |
| 2. SignalAlert™ (Alt. / Phase 2) | 12. DoubleFlash (Sim. / Phase 2) |
| 3. SignalAlert™ (Sim. / Phase 1) | 13. SingleFlash (Alt. / Phase 1) |
| 4. SignalAlert™ (Sim. / Phase 2) | 14. SingleFlash (Alt. / Phase 2) |
| 5. CometFlash® (Alt. / Phase 1) | 15. SingleFlash (Sim. / Phase 1) |
| 6. CometFlash® (Alt. / Phase 2) | 16. SingleFlash (Sim. / Phase 2) |
| 7. CometFlash® (Sim. / Phase 1) | 17. ComAlert™ (Alt. / Phase 1) |
| 8. CometFlash® (Sim. / Phase 2) | 18. ComAlert™ (Alt. / Phase 2) |
| 9. DoubleFlash (Alt. / Phase 1) | 19. ComAlert™ (Sim. / Phase 1) |
| 10. DoubleFlash (Alt. / Phase 2) | 20. ComAlert™ (Sim. / Phase 2) |

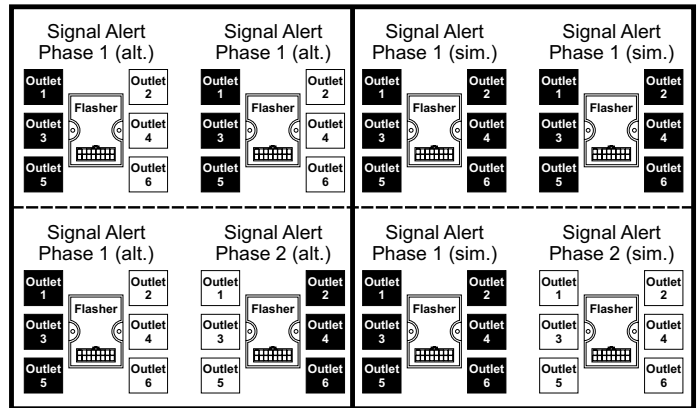

The diagram below shows the relationship between two flashers. Keep in mind that all flashers connected by the Grey wire must be configured to flash the same pattern (as shown, both flashers are displaying Signal Alert™).

Scan-Lock™ / Pattern Selection - To advance to the next pattern, press the momentary switch (step 3) for less than 1 second and release. Hold this switch for more than 1 second to cycle backwards through the patterns.

To reset to the Factory Default Pattern - Turn off power to the flasher. While holding down the momentary switch, turn the flasher on. Continue to hold the switch for 5 seconds.

Pattern Table -

- | | |
|----------------------------------|----------------------------------|
| 1. SignalAlert™ (Alt. / Phase 1) | 11. DoubleFlash (Sim. / Phase 1) |
| 2. SignalAlert™ (Alt. / Phase 2) | 12. DoubleFlash (Sim. / Phase 2) |
| 3. SignalAlert™ (Sim. / Phase 1) | 13. SingleFlash (Alt. / Phase 1) |
| 4. SignalAlert™ (Sim. / Phase 2) | 14. SingleFlash (Alt. / Phase 2) |
| 5. CometFlash® (Alt. / Phase 1) | 15. SingleFlash (Sim. / Phase 1) |
| 6. CometFlash® (Alt. / Phase 2) | 16. SingleFlash (Sim. / Phase 2) |
| 7. CometFlash® (Sim. / Phase 1) | 17. ComAlert™ (Alt. / Phase 1) |
| 8. CometFlash® (Sim. / Phase 2) | 18. ComAlert™ (Alt. / Phase 2) |
| 9. DoubleFlash (Alt. / Phase 1) | 19. ComAlert™ (Sim. / Phase 1) |
| 10. DoubleFlash (Alt. / Phase 2) | 20. ComAlert™ (Sim. / Phase 2) |

