

WHELEN[®]

ENGINEERING COMPANY INC.

51 Winthrop Road
 Chester, Connecticut 06412-0684
 Phone: (860) 526-9504
 Fax: (860) 526-2009
 Internet: www.whelen.com
 Sales/Service e-mail: aviation@whelen.com

Installation Guide: Model 90088()-Series Models: 9008803, 9008804 P/N: 01-0790088-03, 01-0790088-04 LED Ground Recognition Light Assembly

OPERATING INSTRUCTIONS:

Operational Voltage: 28 VDC
 (operation from 22-32 VDC)

Average Input Current: 0.56 Amps

Pulse: 3 Amps

Flashrate 45± 5 FPM

CONTINUED AIRWORTHINESS: Model 90088() LED ground recognition light assembly is designed with 2 banks of 7 LEDs each. If any one LED or bank fail, the unit should be repaired or replaced.

Note: To reduce eye strain use an optical filter such as dark glasses or a blue covering dome during LED inspection. Inspect the lens and replace if there's excessive scratching, pitting, discoloration or cracking.

INSTALLATION PROCEDURES:

The following information is to assist in the installation of a Whelen LED Ground Recognition Light Assembly.

1. Choose the appropriate light assembly. Lower mounts have a drain hole in the lens.
2. Using the mounting detail information provided, prepare the aircraft for means to secure the LED assembly.
3. Connect the light inputs according to the chart shown. Connect the power lead to an appropriately sized breaker. Connections to be in accordance with FAA approved methods.
4. Carefully remove the screws and lens retainer. Remove the lens and gasket from the light assembly. **CAUTION:** Do not touch the LED with either fingers or sharp objects as this could soil and/or damage the LED and effect the optical performance of the light.
5. Using the appropriate hardware install the baseplate gasket and light assembly to the aircraft. Ensure that all leads are clear of any obstacles and are secured as required.
6. Reinstall gasket, lens and retainer. Confirm proper gasket fit. Reinsert screws and tighten firmly.
7. Check all avionics systems for interference from the installation.
8. A flight check should be performed by a properly certified pilot.
9. Update aircraft records, complete Form 337 and obtain FAA field approval for installation, as necessary.

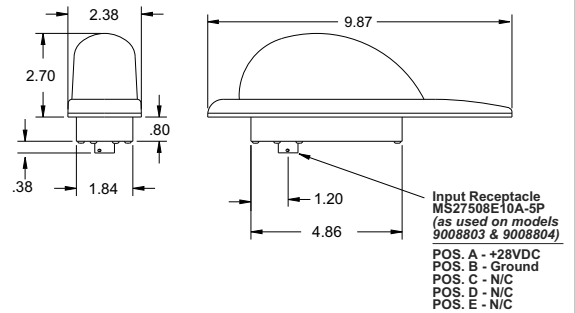
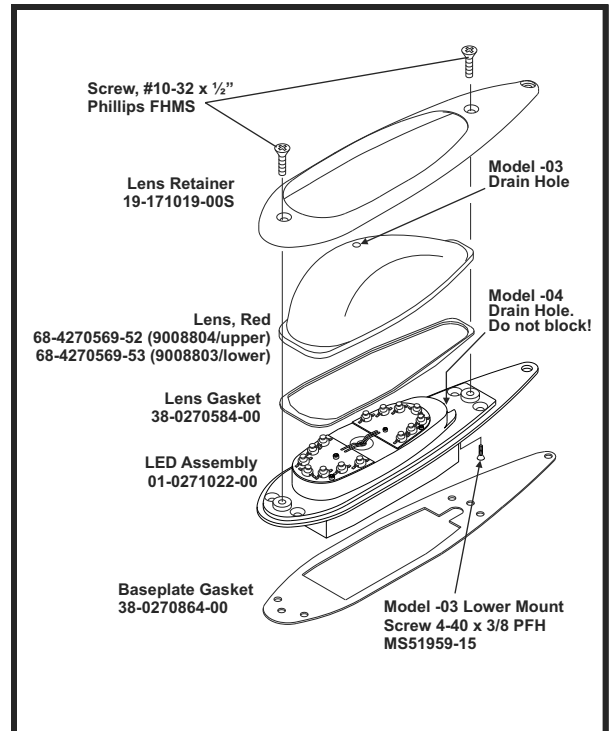

SUGGESTED MOUNTING PATTERN

