

# WHELEN<sup>®</sup>

ENGINEERING COMPANY INC.

Route 145, Winthrop Road,  
Chester, Connecticut 06412  
Phone: (860) 526-9504  
Fax: (860) 526-2009  
Internet: [www.whelen.com](http://www.whelen.com)  
Sales/Service e-mail: [aviation@whelen.com](mailto:aviation@whelen.com)

## Installation Guide: Models 7096600, 7096601, 7096602 P/N:01-0770966-00, 01-0770966-01, 01-0770966-02 LED Tail Position Light Assembly



TSO-C30c  
TYPE III  
APPROVED



The conditions and tests required for TSO approval of this article are minimum performance standards. It is the responsibility of those installing this article either on or within a specific type or class of aircraft to determine that the aircraft installation conditions are within the TSO standards. TSO articles must have separate approval for installation in aircraft. The article may be installed only if performed under 14 CFR part 43 or the applicable airworthiness requirements.

### OPERATING INSTRUCTIONS:

**Nominal Voltage:** . . . . . 28 VDC

**Operational Voltages:** . . . . . 24 - 30 VDC

**Input Current:** . . . . . 0.30 Amps

**EQUIPMENT LIMITATIONS:** The approved tail position light assembly should be mounted vertically and as far aft on the aircraft as possible, on a thermally conductive surface

**CONTINUED AIRWORTHINESS:** The LED tail position light assembly is designed with 6 LED's. If any one LED fails, the unit must be repaired or replaced.

**INSTALLATION PROCEDURES:** The following information is to assist you in installing a Whelen tail position light.

1. Choose the appropriate model light assembly which is most applicable to your aircraft.
2. Remove the old light, locate and save the existing +28VDC lead and (-) ground lead. Clean and prep ends as required.
3. Use the existing mounting holes and hardware.

**Note: If a special adaptor plate is required, contact Whelen Aviation Division for requirements.**

4. Connect the existing +28 VDC lead to the white 20 AWG lead on the input cable assembly (supplied with light assembly). Connect the existing ground lead to the black or white/blue 20 AWG wire on the input cable assembly. If a chassis ground wire exists on the aircraft, connect it to the chassis ground wire assembly. Both leads must be connected by FAA approved techniques using approved hardware.
5. Make sure the existing system is equipped with an appropriate sized breaker.
6. Remove two #4-40 screws from tail light assembly. Save these screws.

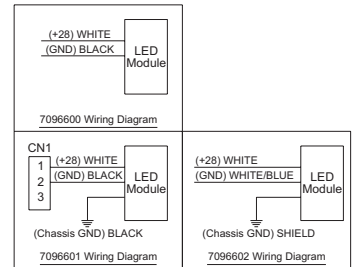
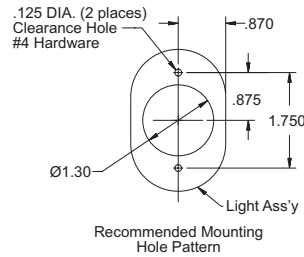
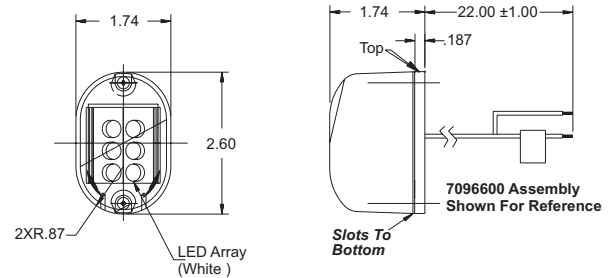

7. Install the light assembly and insure that all the leads are clear of any obstructions and ty-wrap as required. Secure light assembly using approved vibration resistant hardware methods. Note "Top" marking on the unit.
8. Re-mount the lens onto the assembly. Attach lens with mounting screws (provided). **NOTE: These screws feature a nylon thread locking patch.**
9. Check all avionics systems for interference from this installation.
10. When waterproofing the assembly to the aircraft, apply aviation-approved single part silicone (RTV) or equivalent around the periphery with caution. Do not fill the drain holes at bottom of unit. **RTV should never be used between the rear surface of the light assembly and its mounting surface.**
11. Update aircraft records, complete Form 337 and obtain FAA field approval for installation.

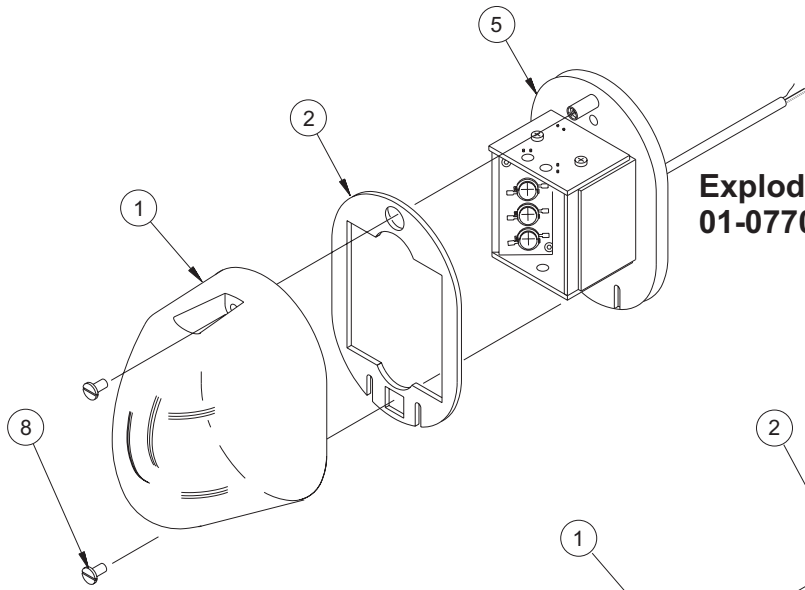

**Exploded View:  
01-0770966-02**

**NOTE (all models):**  
The lens should be periodically inspected for cracks or scratches and replaced as necessary.

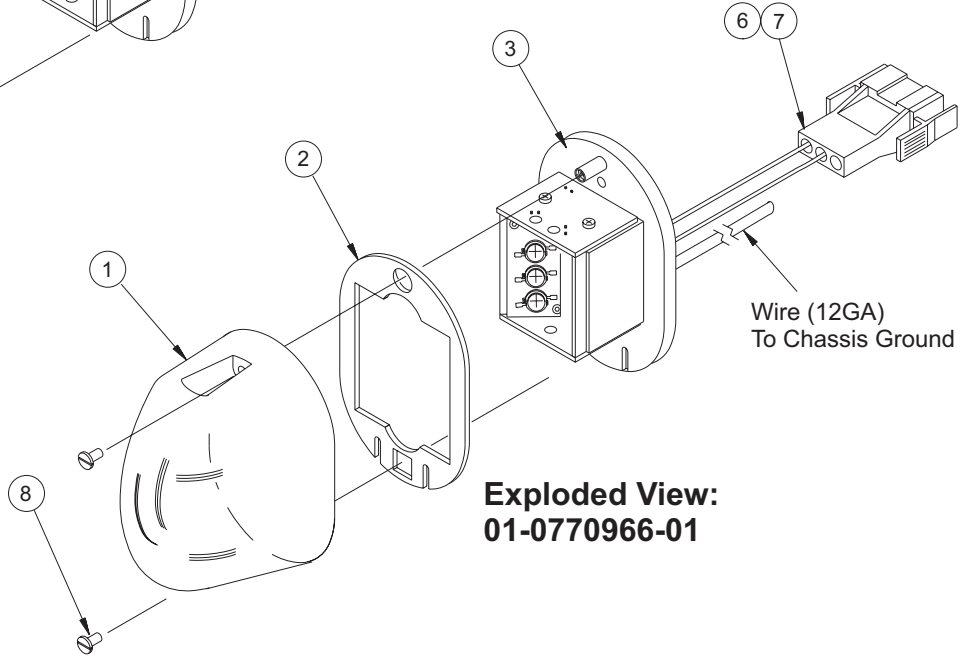

**Exploded View:  
01-0770966-01**

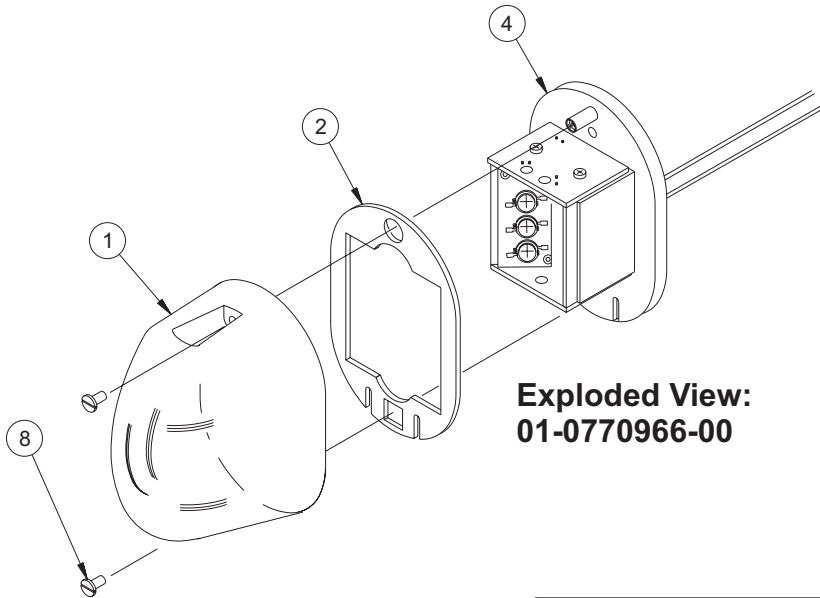

**Exploded View:  
01-0770966-00**

QTY	QTY	QTY	ITEM	PART NUMBER	DESCRIPTION
		*		01-0770966-00	LED TAIL POSITION LIGHT
	*			01-0770966-01	LED TAIL POSITION LIGHT
*				01-0770966-02	LED TAIL POSITION LIGHT
1	1	1	1	68-3970804A30	LENS, LED TAIL POSITION LIGHT
1	1	1	2	38-0250855-00	GASKET, LENS
-	-	1	3	01-0290273-00	LED/PCB MODULE ASSEMBLY
-	1	-	4	01-0290273-01	LED/PCB MODULE ASSEMBLY w/GROUND WIRE
1	-	-	5	01-0290273-02	LED/PCB MODULE ASSEMBLY w/SHIELDED CABLE
-	1	-	6	39-0403024-91	AMP 3-PIN CONN. #207359-1
-	2	-	7	00-0000000-00	AMP PIN #66103-4, 20-24 AWG
2	2	2	8	00-0000000-00	#4 - 40 X 5/16 SLOT SHOULDER (w/Nylon Patch)