

WHELEN[®]

ENGINEERING COMPANY INC.

51 Winthrop Road
Chester, Connecticut 06412-0684
Phone: (860) 526-9504
Fax: (860) 526-4078
Internet: www.whelen.com
Sales e-mail: autosale@whelen.com
Canadian Sales e-mail: autocan@whelen.com
Customer Service e-mail: custserv@whelen.com

Installation Guide:
Edge[®] 4500 Plus+[™] Series Lightbar
Model(s): 45KKKRL, 45KKKFL, 45TA****

Safety First

This document provides all the necessary information to allow your Whelen product to be properly and safely installed. Before beginning the installation and/or operation of your new product, the installation technician and operator must read this manual completely. Important information is contained herein that could prevent serious injury or damage.

- Proper installation of this product requires the installer to have a good understanding of automotive electronics, systems and procedures.
- If mounting this product requires drilling holes, the installer **MUST** be sure that no vehicle components or other vital parts could be damaged by the drilling process. Check both sides of the mounting surface before drilling begins. Also de-burr any holes and remove any metal shards or remnants. Install grommets into all wire passage holes.
- If this manual states that this product may be mounted with suction cups, magnets, tape or Velcro[®], clean the mounting surface with a 50/50 mix of isopropyl alcohol and water and dry thoroughly.
- Do not install this product or route any wires in the deployment area of your air bag. Equipment mounted or located in the air bag deployment area will damage or reduce the effectiveness of the air bag, or become a projectile that could cause serious personal injury or death. Refer to your vehicle owner's manual for the air bag deployment area. The User/Installer assumes full responsibility to determine proper mounting location, based on providing ultimate safety to all passengers inside the vehicle.
- For this product to operate at optimum efficiency, a good electrical connection to chassis ground must be made. The recommended procedure requires the product ground wire to be connected directly to the **NEGATIVE (-)** battery post.
- If this product uses a remote device to activate or control this product, make sure that this control is located in an area that allows both the vehicle and the control to be operated safely in any driving condition.
- Do not attempt to activate or control this device in a hazardous driving situation.
- This product contains either strobe light(s), halogen light(s), high-intensity LEDs or a combination of these lights. Do not stare directly into these lights. Momentary blindness and/or eye damage could result.
- Use only soap and water to clean the outer lens. Use of other chemicals could result in premature lens cracking (crazing) and discoloration. Lenses in this condition have significantly reduced effectiveness and should be replaced immediately. Inspect and operate this product regularly to confirm its proper operation and mounting condition. Do not use a pressure washer to clean this product.
- It is recommended that these instructions be stored in a safe place and referred to when performing maintenance and/or reinstallation of this product.
- **FAILURE TO FOLLOW THESE SAFETY PRECAUTIONS AND INSTRUCTIONS COULD RESULT IN DAMAGE TO THE PRODUCT OR VEHICLE AND/OR SERIOUS INJURY TO YOU AND YOUR PASSENGERS!**

For warranty information regarding this product, visit www.whelen.com/warranty

IMPORTANT! The lightbar should be located a minimum of 16" from any radio antennas!

Installation:

Note: When routing the wires, it is important to choose a path that will keep these wires away from excessive heat and from any vehicle equipment that could compromise the integrity of the wires (ex. trunk lids, door jams, etc.).

1. This lightbar attaches to the vehicle by 1-1/4" bolts extending from the rear of the housing. Position the unit in its proposed mounting location to ensure that it fits properly. With the lightbar in place, use an awl or other suitable tool and scribe the areas to be drilled.
2. Remove the lightbar from its mounting area and, using an appropriately sized drill bit, drill a hole in each of the areas scribed in step 1.
3. Return the lightbar to its mounting location and using the supplied hardware, secure it to the vehicle.

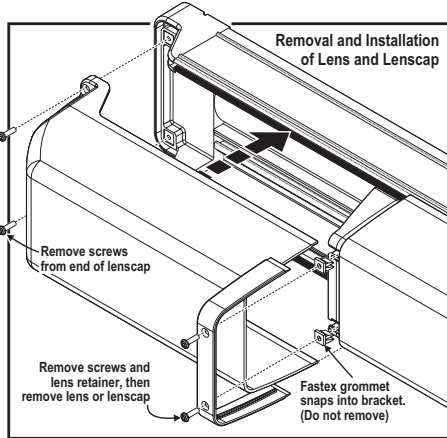
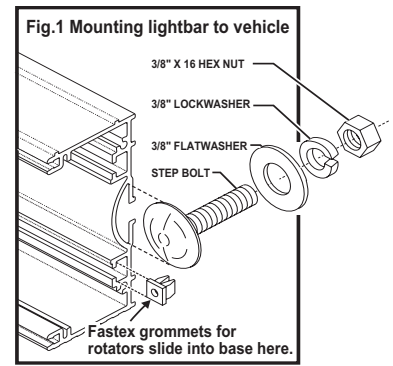

Wiring:

Extend the control wires to your switch panel and make the appropriate connections using the wiring information provided in this manual.

Servicing your Lightbar:

This section will cover the removal and installation of the components of your lightbar for repair or replacement purposes.

Lens or Lenscap: Removal or Installation

To remove a lenscap, remove the 2 screws from the end of the lenscap that thread into the lightbar base. Remove the 2 screws from the opposite side that thread through the lens retainer into the lighthouse mounting bracket. Pull the lenscap off.

To remove a lens, remove the 4 phillips head screws that thread through the lens retainer into the lighthouse mounting bracket and then pull the lens off. NOTE: Be sure the gaskets are properly seated before remounting.

Corner Linear-LED® Removal:

1. Disconnect the lightbar from its power source and remove the endcap in front of the lighthouse you wish to replace or service.
2. Spread the ends of the corner strobe support bracket (A) apart to disengage it from the tab on the lighthouse, and lift this end of the lighthouse out.
3. Pull the clips back on the mounting bracket (B) as you lift the lighthouse off of the two raised bosses on the bracket, then carefully lift the lighthouse out of the lightbar base and disconnect the power cord (C), and remove the lighthouse from the lightbar.

Corner Linear-LED® Installation:

1. Plug the lighthouse into the wiring harness (C).
2. Insert the end of the bracket into the 2 bosses, and snap the side of the lighthouse into the clips in the bracket (B), then snap the lighthouse tab into the corner strobe support bracket (A) and replace the endcap. Reconnect to power.

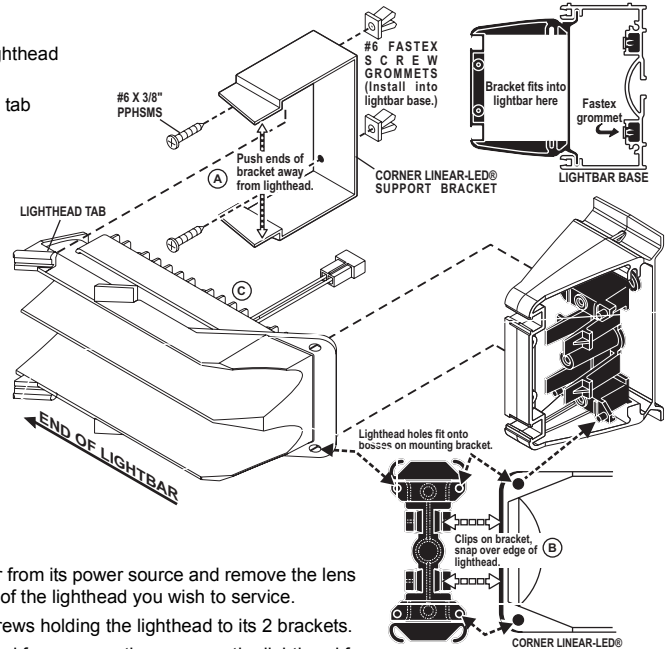

Halogen Lighthouse: Load Light / Rear Facing

Removal:

1. Disconnect the lightbar from its power source and remove the lens and/or endcap in front of the lighthouse you wish to service.
2. Unscrew the 4 lens screws holding the lighthouse to its 2 brackets.
3. Disconnect the lighthouse from power, then remove the lighthouse from the lightbar.

Installation:

1. Plug the lighthouse connector into the lightbar harness.
2. Attach the lighthouse (and lens) to its mounting brackets using the lens screws you removed.
3. Replace the lightbar lenses or endcaps and the installation is complete.

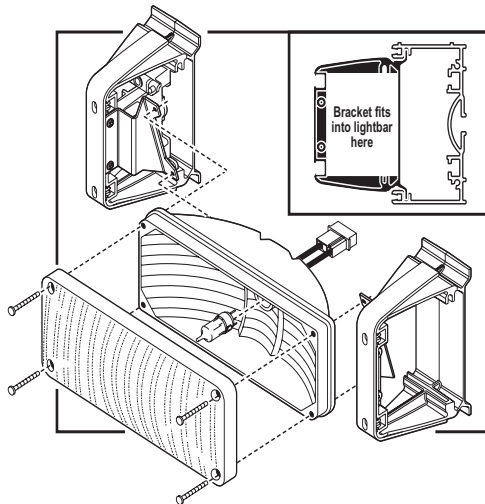

Removal or Installation / Halogen or LED Lighthouse:

1. Disconnect the lightbar from its power source and first remove the lens or lenscap necessary to access the lighthouse you wish to service or replace.
2. Pull the clips back on the mounting bracket that secure the lighthouse as you lift the lighthouse off of the raised bosses on the bracket.
3. Carefully lift the lighthouse out of the lightbar base, disconnect its connector from the lightbar wiring harness, then lift the lighthouse out of the lightbar.
4. To reinstall the lighthouse, plug the lighthouse connector into the lightbar, snap it back into the brackets and replace any lenses or lenscaps you had to remove.

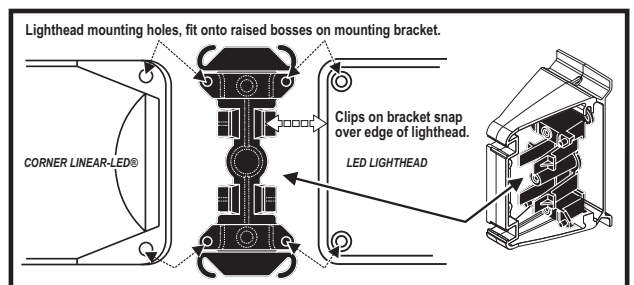

OPTION 1: ADD LEDS with FLASHER. Flasher mounts behind lighthouse on passenger side

POS 1: BLACK
POS 2: RED
POS 3: WHITE
POS 4: NC

OPTION 2: ADD LEDS
Requires External Flasher

+12 VDC
GROUND
+12 VDC
GROUND

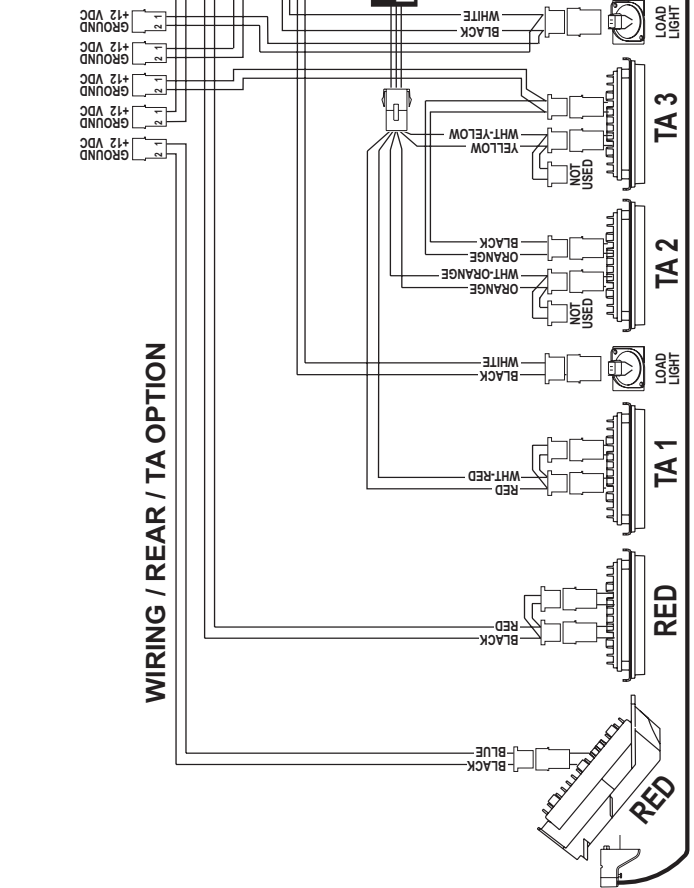
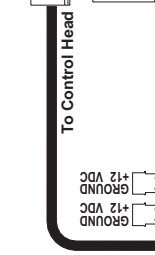
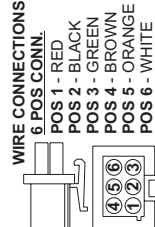
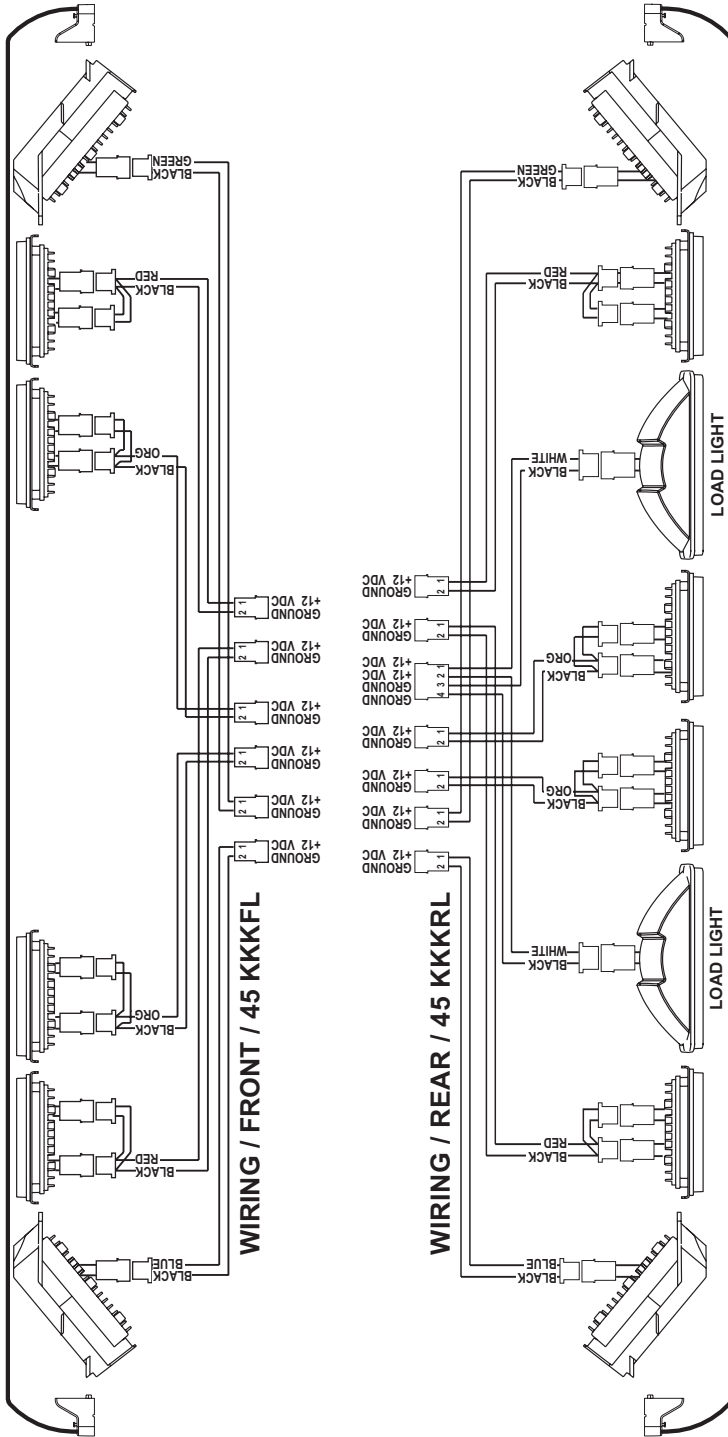
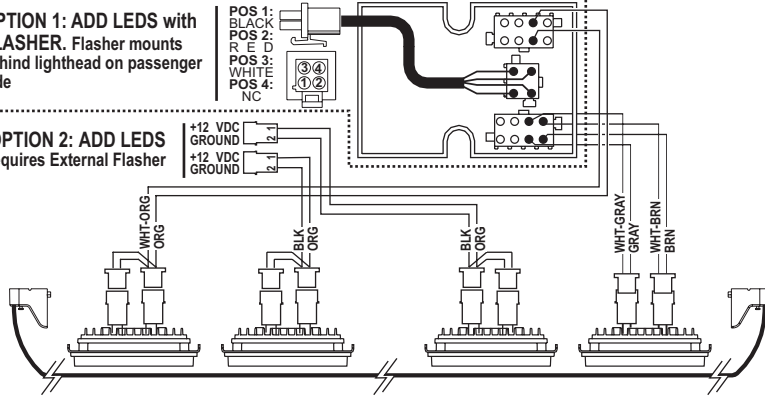

QTY	QTY	ITEM	PART NUMBER	DESCRIPTION
*			01-0684015-00	LIGHTBAR 45KKKRL / REAR
*			01-0684015-01	LIGHTBAR 45KKKFL / FRONT
*			01-0684015-10	LIGHTBAR 45TA*** / REAR with TA OPTION
4	4	1	14-104286-16JA	SCREW / 10-24 X 1.25" TX PAN HD SWEDGE FORM
4	4	2	16-1001620-35	WASHER / #10 FLAT
2	2	3	02-0342932-00	SUB ASSY / MOUNTING BASE
A/R	A/R	4	11-463582-***	EXTRUSION / MACHINED
A/R	A/R	5	02-0483903-A0	ASSY / LED ICC LIGHTS - AMBER
A/R	A/R	6	02-0483903-R0	ASSY / LED ICC-BTT LIGHTS - RED
4	4	7	01-0441771-00	KIT / MOUNTING STEP BOLT
1	1	8	10-0522977-01	LABEL
1	1	9	21-11263204-0	1" GROMMET
4	4	10	15-06121B-082	SCREW / #6 X 1/2" PPHSMS TYPE A BLK SS
A/R	A/R	11	38-0522954-00	SEAL / CORD / FT
4	4	12	02-0342933-00	SUB ASSY / DIVIDER
2	2	13	11-920397-000	LOUVER / 1" 6 TAB with SCREEN
2	2	14	38-0223051-00	FILTER / AIR VENT
-	-	A/R	02-0483910-**	SUB ASSY / LOAD LIGHTS 4500 SERIES
A/R	A/R	16	02-0363932-***	ASSY / 400 LINEAR-LED@ SPLIT
A/R	A/R	17	02-0463748-**	ASSY / CORNER LED 4500 SERIES
A/R	A/R	18	68-3983813-***	LENSCAP

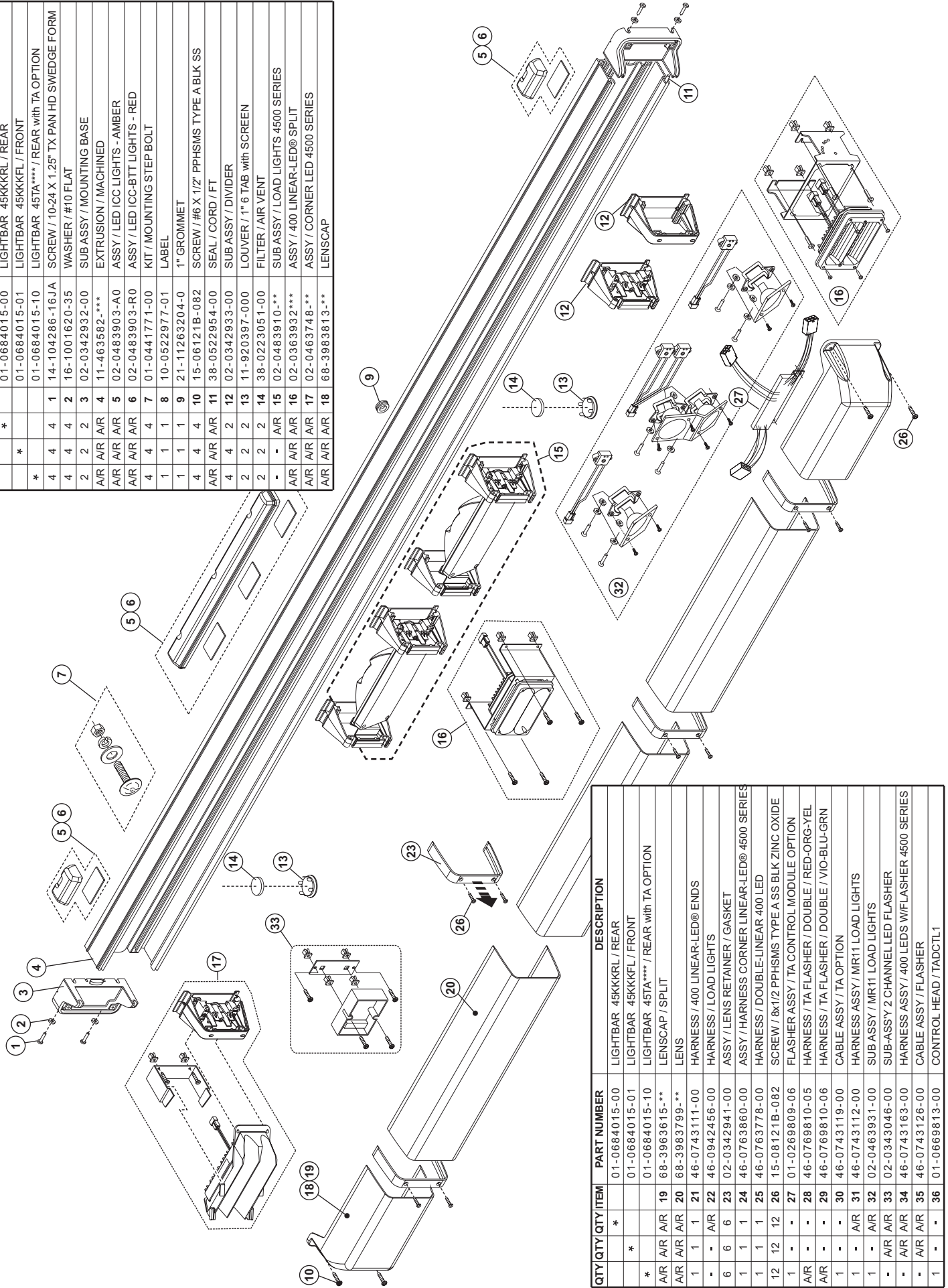

QTY	QTY	ITEM	PART NUMBER	DESCRIPTION
*			01-0684015-00	LIGHTBAR 45KKKRL / REAR
*			01-0684015-01	LIGHTBAR 45KKKFL / FRONT
*			01-0684015-10	LIGHTBAR 45TA*** / REAR with TA OPTION
A/R	A/R	19	68-3983813-***	LENSCAP / SPLIT
A/R	A/R	20	68-3983799-**	LENS
1	1	21	46-0743111-00	HARNES / 400 LINEAR-LED@ ENDS
-	A/R	22	46-0942456-00	HARNES / LOAD LIGHTS
6	6	23	02-0342941-00	ASSY / LENS RETAINER / GASKET
1	1	24	46-0763860-00	ASSY / HARNES CORNER LINEAR-LED@ 4500 SERIES
1	1	25	46-0763778-00	HARNES / DOUBLE-LINEAR 400 LED
12	12	26	15-08121B-082	SCREW / #8X1/2 PPHSMS TYPE A SS BLK ZINC OXIDE
1	-	27	01-0269809-06	FLASHER ASSY / TA CONTROL MODULE OPTION
A/R	-	28	46-0769810-05	HARNES / TA FLASHER / DOUBLE / RED-ORG-YEL
A/R	-	29	46-0769810-06	HARNES / TA FLASHER / DOUBLE / VIO-BLU-GRN
1	-	30	46-0743119-00	CABLE ASSY / TA OPTION
1	-	31	46-0743112-00	HARNES ASSY / MR11 LOAD LIGHTS
1	-	32	02-0463931-00	SUB ASSY / MR11 LOAD LIGHTS
-	A/R	33	02-0343046-00	SUB-ASSY 2 CHANNEL LED FLASHER
-	A/R	34	46-0743163-00	HARNES ASSY / 400 LEDS W/FLASHER 4500 SERIES
-	A/R	35	46-0743126-00	CABLE ASSY / FLASHER
1	-	36	01-0669813-00	CONTROL HEAD / TADCTL1