

WHELEN[®]

ENGINEERING COMPANY INC.

51 Winthrop Road
Chester, Connecticut 06412-0684
Phone: (860) 526-9504
Fax: (860) 526-4078
Internet: www.whelen.com
Sales e-mail: autosale@whelen.com
Canadian Sales e-mail: canadiansales@whelen.com
Customer Service e-mail: custserv@whelen.com

Installation Guide: Dominator Series Traffic Advisor™

Warnings to Installers

Whelen's emergency vehicle warning devices must be properly mounted and wired in order to be effective and safe. Read and follow all of Whelen's written instructions when installing or using this device. Emergency vehicles are often operated under high speed stressful conditions which must be accounted for when installing all emergency warning devices. Controls should be placed within convenient reach of the operator so that they can operate the system without taking their eyes off the roadway. Emergency warning devices can require high electrical voltages and/or currents. Properly protect and use caution around live electrical connections. Grounding or shorting of electrical connections can cause high current arcing, which can cause personal injury and/or vehicle damage, including fire. Many electronic devices used in emergency vehicles can create or be affected by electromagnetic interference. Therefore, after installation of any electronic device it is necessary to test all electronic equipment simultaneously to insure that they operate free of interference from other components within the vehicle. Never power emergency warning equipment from the same circuit or share the same grounding circuit with radio communication equipment. All devices should be mounted in accordance with the manufacturer's instructions and securely fastened to vehicle elements of sufficient strength to withstand the forces applied to the device. Driver and/or passenger air bags (SRS) will affect the way equipment should be mounted. This device should be mounted by permanent installation and within the zones specified by the vehicle manufacturer, if any. Any device mounted in the deployment area of an air bag will damage or reduce the effectiveness of the air bag and may damage or dislodge the device. Installer must be sure that this device, its mounting hardware and electrical supply wiring does not interfere with the air bag or the SRS wiring or sensors. Mounting the unit inside the vehicle by a method other than permanent installation is not recommended as unit may become dislodged during swerving; sudden braking or collision. Failure to follow instructions can result in personal injury. Whelen assumes no liability for any loss resulting from the use of this warning device. PROPER INSTALLATION COMBINED WITH OPERATOR TRAINING IN THE PROPER USE OF EMERGENCY WARNING DEVICES IS ESSENTIAL TO INSURE THE SAFETY OF EMERGENCY PERSONNEL AND THE PUBLIC.

Warnings to Users

Whelen's emergency vehicle warning devices are intended to alert other operators and pedestrians to the presence and operation of emergency vehicles and personnel. However, the use of this or any other Whelen emergency warning device does not guarantee that you will have the right-of-way or that other drivers and pedestrians will properly heed an emergency warning signal. Never assume you have the right-of-way. It is your responsibility to proceed safely before entering an intersection, driving against traffic, responding at a high rate of speed, or walking on or around traffic lanes. Emergency vehicle warning devices should be tested on a daily basis to ensure that they operate properly. When in actual use, the operator must ensure that both visual and audible warnings are not blocked by vehicle components (i.e.: open trunks or compartment doors), people, vehicles, or other obstructions. It is the user's responsibility to understand and obey all laws regarding emergency warning devices. The user should be familiar with all applicable laws and regulations prior to the use of any emergency vehicle warning device. Whelen's audible warning devices are designed to project sound in a forward direction away from the vehicle occupants. However, because sustained periodic exposure to loud sounds can cause hearing loss, all audible warning devices should be installed and operated in accordance with the standards established by the National Fire Protection Association.

Safety First

This document provides all the necessary information to allow your Whelen product to be properly and safely installed. Before beginning the installation and/or operation of your new product, the installation technician and operator must read this manual completely. Important information is contained herein that could prevent serious injury or damage.

- **Proper installation of this product requires the installer to have a good understanding of automotive electronics, systems and procedures.**
- **Whelen Engineering requires the use of waterproof butt splices and/or connectors if that connector could be exposed to moisture.**
- **Failure to use specified installation parts and/or hardware will void the product warranty.**
- **If mounting this product requires drilling holes, the installer MUST be sure that no vehicle components or other vital parts could be damaged by the drilling process. Check both sides of the mounting surface before drilling begins. Also de-burr the holes and remove any metal shards or remnants. Install grommets into all wire passage holes.**
- **If this manual states that this product may be mounted with suction cups, magnets, tape or Velcro®, clean the mounting surface with a 50/50 mix of isopropyl alcohol and water and dry thoroughly.**
- **Do not install this product or route any wires in the deployment area of your air bag. Equipment mounted or located in the air bag deployment area will damage or reduce the effectiveness of the air bag, or become a projectile that could cause serious personal injury or death. Refer to your vehicle owner's manual for the air bag deployment area. The User/Installer assumes full responsibility to determine proper mounting location, based on providing ultimate safety to all passengers inside the vehicle.**
- **For this product to operate at optimum efficiency, a good electrical connection to chassis ground must be made. The recommended procedure requires the product ground wire to be connected directly to the NEGATIVE (-) battery post (this does not include products that use cigar power cords).**
- **If this product uses a remote device for activation or control, make sure that this device is located in an area that allows both the vehicle and the device to be operated safely in any driving condition.**
- **Do not attempt to activate or control this device in a hazardous driving situation.**
- **This product contains either strobe light(s), halogen light(s), high-intensity LEDs or a combination of these lights. Do not stare directly into these lights. Momentary blindness and/or eye damage could result.**
- **Use only soap and water to clean the outer lens. Use of other chemicals could result in premature lens cracking (crazing) and discoloration. Lenses in this condition have significantly reduced effectiveness and should be replaced immediately. Inspect and operate this product regularly to confirm its proper operation and mounting condition. Do not use a pressure washer to clean this product.**
- **It is recommended that these instructions be stored in a safe place and referred to when performing maintenance and/or reinstallation of this product.**
- **FAILURE TO FOLLOW THESE SAFETY PRECAUTIONS AND INSTRUCTIONS COULD RESULT IN DAMAGE TO THE PRODUCT OR VEHICLE AND/OR SERIOUS INJURY TO YOU AND YOUR PASSENGERS!**

Installation:

WARNING! When the Traffic Advisor™ is mounted to the rear of the vehicle, the cable exit must be on the passenger side. If not, the flash sequence you choose on the control head will be incorrect. For example a left flashing pattern will flash right.

- Position the unit in its proposed mounting location to ensure that it fits properly. Draw a pencil line on the mounting surface using the top and bottom of the extrusion as a guide.
- Two 1/4" holes are required to mount this unit. These holes may be located anywhere along the horizontal centerline of the unit, but must be centered between the upper and lower lines made in step 1. It's best to locate the mounting holes as far apart as possible.
- Drill a hole in each of the areas scribed in the last step (1/4" drill bit).
- Slide the 2 carriage bolts (installed in the rear of the bar) over to the 2 mounting holes, install the rubber gaskets onto the bolts as shown then insert them into the mounting holes
- Secure the unit by threading the flat washer and elastic stop nut onto each bolt and tightening them firmly.

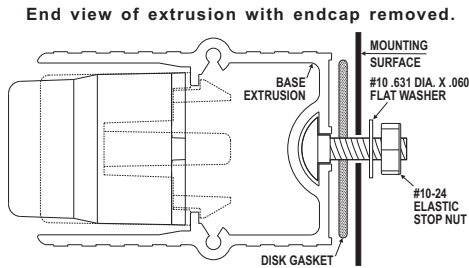

WARNING! All customer supplied wires that connect to the positive terminal of the battery must be sized to supply at least 125% of the maximum operating current and FUSED at the battery to carry the load. **DO NOT USE CIRCUIT BREAKERS WITH THIS PRODUCT!**

WIRING DIAGRAM

IMPORTANT: Switches must be sized to accommodate a minimum of 5 Amps.

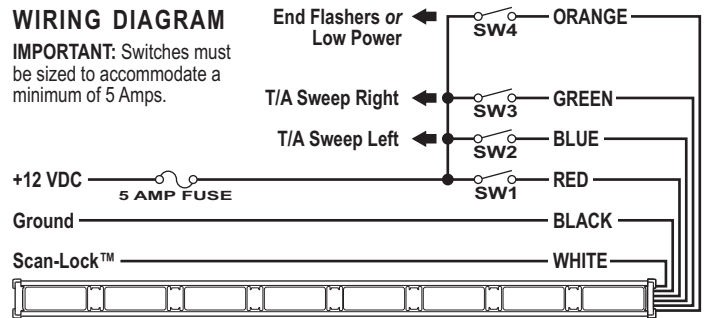

Scan-Lock™ can select a different pattern for END FLASHERS, T/A and FLASHERS.

Patterns (Flashers or End Flashers):

- SignalAlert™
- CometFlash®
- SingleFlash 375
- SingleFlash 150
- SingleFlash 75
- ActionFlash™
- ActionScan™

T/A Patterns:

- Seq.On (Solid)
- Seq.On - Seq.Off
- 1-Lamp TripleFlash™
- 2-Lamp TripleFlash™

FUNCTION	SWITCHES			
	SW1	SW2	SW3	SW4
Left Sweep	ON	ON	OFF	OFF
Right Sweep	ON	OFF	ON	OFF
Split Sweep	ON	ON	ON	OFF
TA Flasher	ON	OFF	OFF	OFF
End Flashers	X	X	X	ON

X = Switch position doesn't affect operation.

Low Power / Orange Wire: If your lightbar is not equipped with End Flashers the ORANGE wire will activate Low Power. This feature steps the lightbar down to low power for nighttime use. Applying +12 volts to the ORANGE wire holds the Traffic Advisor in low power mode until voltage is removed. (a toggle switch is recommended).

Scan-Lock™ / White Wire:

Operation: With the lightbar switched on, activate whichever function you wish to change the flash pattern of and follow the instructions below.

TO CYCLE THROUGH ALL PATTERNS: Apply +12 volts to the WHITE wire for less than 1 second and release to cycle forward. Apply +12 volts to the WHITE wire for more than 1 second and release to cycle backward.

TO SET A PATTERN AS DEFAULT: Allow the desired pattern to run for more than 5 seconds. The lighthead will now display this pattern when active.

TO RESET TO THE FACTORY DEFAULT PATTERN: Turn off power and apply +12 volts to the WHITE wire while turning power on.

You may want to connect the Scan-Lock™ wire to a switch. An SPST momentary switch is recommended.

IMPORTANT WARNING!

CAUTION! DO NOT LOOK DIRECTLY AT THESE LEDS WHILE THEY ARE ON. MOMENTARY BLINDNESS AND/OR EYE DAMAGE COULD RESULT!

PART NUMBER KEY:
For TA 8 Light with End Flashers
01-0684608-

#2 End Flasher Color
#1 End Flasher Color

END FLASHER COLORS:

- 1 = AMBER
- 2 = BLUE
- 3 = WHITE
- 4 = RED

QTY	QTY	QTY	ITEM	PART NUMBER	DESCRIPTION
		*		01-0684608-06	Dominator™ T/A - 6 Lighthead (23.26")
		*		01-0684608-08	Dominator™ T/A - 8 Lighthead (30.36")
	*			01-0684608-__	Dominator™ T/A - 6 w/End Flashers (30.36")
1	1	1	1	11-263726-000	ENDCAP, 3TIR (w/o HOLE)
9	9	7	2	38-0463725-00	DIVIDER, EXTRUSION MOUNT
A/R	8	6	3	02-036B494612	LIGHTHEAD, 3TIR LED (AMB-STEADY)
A/R	-	-	4	02-036B494622	LIGHTHEAD, 3TIR LED (BLU-STEADY)
A/R	-	-	5	02-036B494632	LIGHTHEAD, 3TIR LED (WHT-STEADY)
A/R	-	-	6	02-036B494652	LIGHTHEAD, 3TIR LED (RED-STEADY)
-	-	1	7	01-0269778-A6	MODULE, T/A 6-LIGHT
-	1	-	8	01-0269778-A8	MODULE, T/A 8-LIGHT
1	-	-	9	01-0269778A6F	MODULE, T/A 8-LIGHT w/END FLASHERS
1	1	1	10	46-0743389-00	CABLE w/CONNECTOR & ENDCAP
-	-	1	11	11-443031-022	EXTRUSION - 22.90"
1	1	-	12	11-443031-030	EXTRUSION - 30.00"
4	4	4	13	14-062219-06D	SCREW, #6-32 X 3/8 PPHMS ROLOK ZN
2	2	2	14	14-104066-100	CARRIAGE BOLT, #10-24 X 5/8 LG SS
2	2	2	15	38-0223063-00	GASKET, DISK
2	2	2	16	16-1002220-50	WASHER, #10 FLAT .631 DIA. X .060
2	2	2	17	13-104120-062	NUT, #10-24 ELASTIC STOP
1	1	1	18	21-11121602-0	GROMMET, 1/2"
1	1	1	19	26-0215001-06	TY-WRAP, 6" BLACK

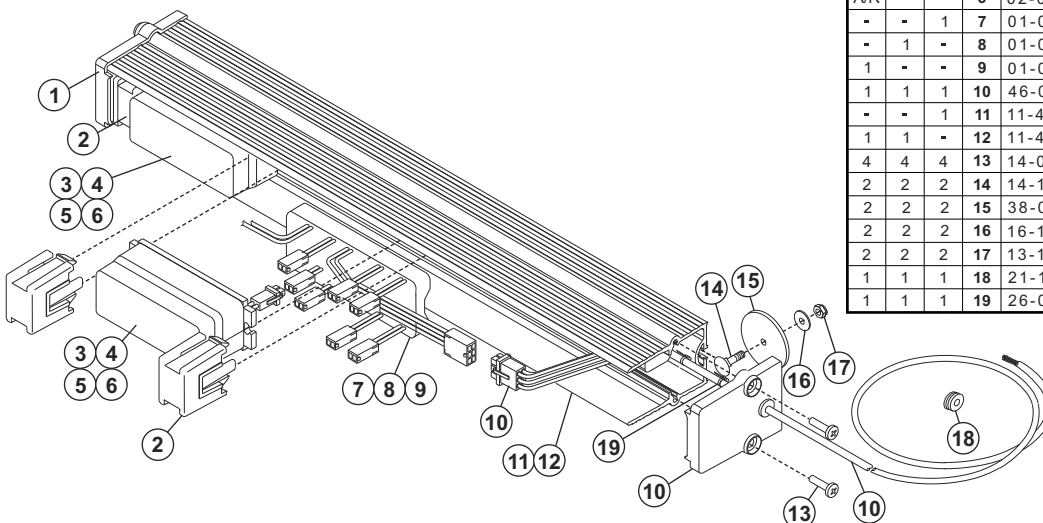

Note: Optional, non-Standard length cables are not for use with Sequence to Solid or Sequence On/Off flash patterns.