

# WHELEN<sup>®</sup>

ENGINEERING COMPANY INC.

51 Winthrop Road,  
Chester, Connecticut 06412-0684  
Phone: (860) 526-9504  
Fax: (860) 526-4078

## Installation Guide: TADCTL1 Control Head for the Dominator™ Series Traffic Advisor™ Lightbar

Internet: [www.whelen.com](http://www.whelen.com)  
Sales e-mail: [autosale@whelen.com](mailto:autosale@whelen.com)  
Canadian Sales e-mail: [autocan@whelen.com](mailto:autocan@whelen.com)  
Customer Service e-mail: [custserv@whelen.com](mailto:custserv@whelen.com)

### Installation: Mounting Control Head

1. Position the bail strap in the selected mounting location. Using an awl or other suitable tool, scribe the surface where the mounting holes are to be drilled.

**CAUTION:** As mounting will require drilling, it is absolutely necessary to make sure that no other vehicle components could be damaged in the process. Check both sides of the mounting surface before starting. If damage is likely, select a different mounting location.

2. Carefully drill the mounting holes in the areas scribed in step one. The size of the drill bit should be determined by the size of the mounting hardware (customer supplied) and the thickness of the mounting surface.
3. Using the customer supplied mounting hardware, secure the bail strap to the mounting location.

**NOTE:** There are 2 sets of holes on the bail strap that can be used to position the control head at 2 different heights.

4. With the bail strap in place, insert the carriage bolt along with the external tooth lockwasher (supplied) into the assembly hole from the inner side of the bail strap as shown.
5. Place the split lockwasher and the acorn nut on the protruding bolt on the outer side of the bail strap. Loosely secure the acorn nut to the carriage bolt.
6. Now slide the control head onto the carriage bolts. Once it is in the position that the customer has chosen, tighten the acorn nuts until the unit is firmly secured.

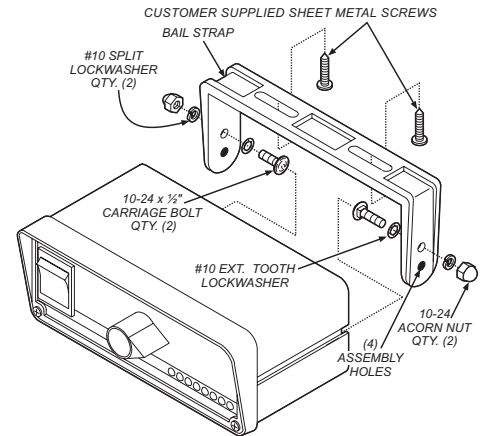

©2004 Whelen Engineering Company Inc.  
Form No.13908B (073107)

For warranty information regarding this product, visit [www.whelen.com/warranty](http://www.whelen.com/warranty)

# WHELEN<sup>®</sup>

ENGINEERING COMPANY INC.

51 Winthrop Road,  
Chester, Connecticut 06412-0684  
Phone: (860) 526-9504  
Fax: (860) 526-4078

## Installation Guide: TADCTL1 Control Head for the Dominator™ Series Traffic Advisor™ Lightbar

Internet: [www.whelen.com](http://www.whelen.com)  
Sales e-mail: [autosale@whelen.com](mailto:autosale@whelen.com)  
Canadian Sales e-mail: [autocan@whelen.com](mailto:autocan@whelen.com)  
Customer Service e-mail: [custserv@whelen.com](mailto:custserv@whelen.com)

### Installation: Mounting Control Head

1. Position the bail strap in the selected mounting location. Using an awl or other suitable tool, scribe the surface where the mounting holes are to be drilled.

**CAUTION:** As mounting will require drilling, it is absolutely necessary to make sure that no other vehicle components could be damaged in the process. Check both sides of the mounting surface before starting. If damage is likely, select a different mounting location.

2. Carefully drill the mounting holes in the areas scribed in step one. The size of the drill bit should be determined by the size of the mounting hardware (customer supplied) and the thickness of the mounting surface.
3. Using the customer supplied mounting hardware, secure the bail strap to the mounting location.

**NOTE:** There are 2 sets of holes on the bail strap that can be used to position the control head at 2 different heights.

4. With the bail strap in place, insert the carriage bolt along with the external tooth lockwasher (supplied) into the assembly hole from the inner side of the bail strap as shown.
5. Place the split lockwasher and the acorn nut on the protruding bolt on the outer side of the bail strap. Loosely secure the acorn nut to the carriage bolt.
6. Now slide the control head onto the carriage bolts. Once it is in the position that the customer has chosen, tighten the acorn nuts until the unit is firmly secured.

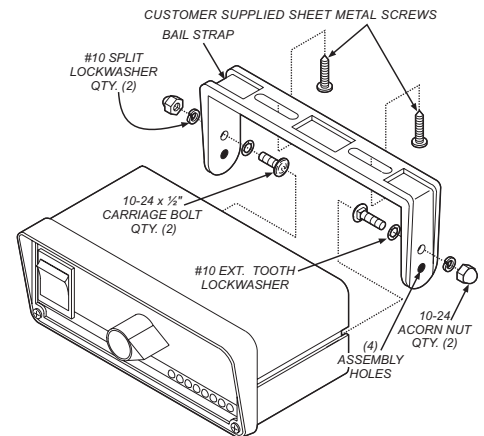

©2004 Whelen Engineering Company Inc.  
Form No.13908B (073107)

For warranty information regarding this product, visit [www.whelen.com/warranty](http://www.whelen.com/warranty)

**OPERATION:**

**ROCKER SWITCH IS SET TO ON:**

**Rotary switch turned to the LEFT:**  
the flash pattern will sweep to the left.

**Rotary switch turned to the RIGHT:**  
the flash pattern will sweep to the right.

**Rotary switch turned to the CENTER:**  
the flash pattern will start at the center and sweep out to the two ends.

**ROCKER SWITCH IS SET TO AUX:**

Same operation as above except, if equipped with end flashers they will activate. If not, nothing will happen.

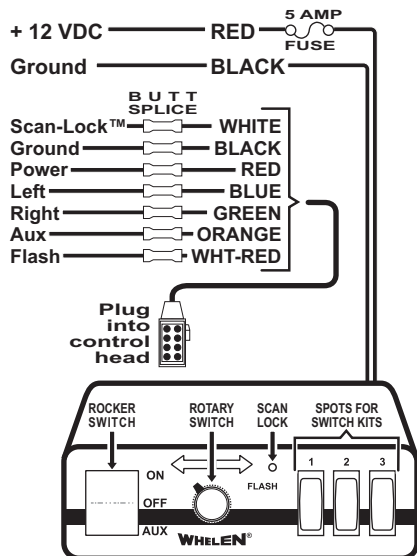

**OPERATION:**

**ROCKER SWITCH IS SET TO ON:**

**Rotary switch turned to the LEFT:**  
the flash pattern will sweep to the left.

**Rotary switch turned to the RIGHT:**  
the flash pattern will sweep to the right.

**Rotary switch turned to the CENTER:**  
the flash pattern will start at the center and sweep out to the two ends.

**ROCKER SWITCH IS SET TO AUX:**

Same operation as above except, if equipped with end flashers they will activate. If not, nothing will happen.

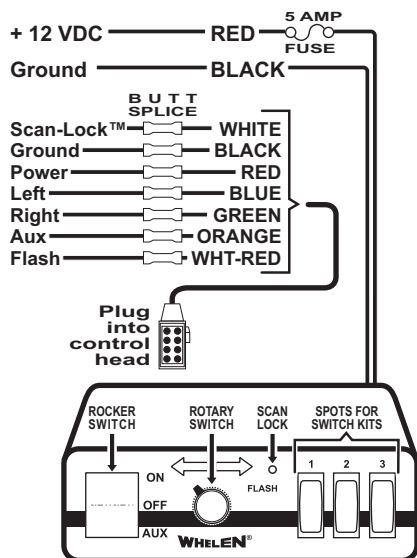

**Scan-Lock™:** This feature allows the user to select from a variety of flash patterns.

Use an implement with a diameter of 1/8" or less, to press the switch (momentary) located under the surface of the face plate. Follow the instructions below. Pressing the switch will apply power only while the switch is engaged.

**TO CYCLE THROUGH ALL PATTERNS:** Press the Scan-Lock button for less than 1 second and release to cycle forward. Press the Scan-Lock button for more than 1 second and release to cycle backward.

**TO SET A PATTERN AS DEFAULT:** When the desired pattern is displayed, allow it to run for more than 5 seconds. The TA will now display this pattern when active.

**RESET TO FACTORY DEFAULT PATTERN:** Turn off power, press the Scan-Lock button, then turn power on.

**With the ROTARY SWITCH set to FLASH MODE:** Scan-Lock will operate with the flash patterns listed below.

**Available Flash Patterns - 6 & 8 Lamp Arrays:** SignalAlert™75, CometFlash@75, SingleFlash 375, SingleFlash 150, ActionScan™, ActionFlash™, SingleFlash 75

**With the ROTARY SWITCH set to ANY OTHER POSITION:** Scan-Lock will operate with the flash patterns listed below.

**Available Flash Patterns - 6 & 8 Lamp Arrays (All modes except Flash):** Sequence On / Sequence Off, 1-Lamp TripleFlash™, 2-Lamp TripleFlash

**In a TA equipped with End Flashers:**

**With the ROTARY SWITCH set to FLASH MODE and the ROCKER SWITCH on AUX:** Scan-Lock will operate with the flash patterns listed below.

**Available Flash Patterns - 6 & 8 Lamp Arrays (Flash Mode):** SignalAlert™75, CometFlash@75, SingleFlash 375, SingleFlash 150, ActionScan™, ActionFlash™, SingleFlash 75

**Scan-Lock™:** This feature allows the user to select from a variety of flash patterns.

Use an implement with a diameter of 1/8" or less, to press the switch (momentary) located under the surface of the face plate. Follow the instructions below. Pressing the switch will apply power only while the switch is engaged.

**TO CYCLE THROUGH ALL PATTERNS:** Press the Scan-Lock button for less than 1 second and release to cycle forward. Press the Scan-Lock button for more than 1 second and release to cycle backward.

**TO SET A PATTERN AS DEFAULT:** When the desired pattern is displayed, allow it to run for more than 5 seconds. The TA will now display this pattern when active.

**RESET TO FACTORY DEFAULT PATTERN:** Turn off power, press the Scan-Lock button, then turn power on.

**With the ROTARY SWITCH set to FLASH MODE:** Scan-Lock will operate with the flash patterns listed below.

**Available Flash Patterns - 6 & 8 Lamp Arrays:** SignalAlert™75, CometFlash@75, SingleFlash 375, SingleFlash 150, ActionScan™, ActionFlash™, SingleFlash 75

**With the ROTARY SWITCH set to ANY OTHER POSITION:** Scan-Lock will operate with the flash patterns listed below.

**Available Flash Patterns - 6 & 8 Lamp Arrays (All modes except Flash):** Sequence On / Sequence Off, 1-Lamp TripleFlash™, 2-Lamp TripleFlash

**In a TA equipped with End Flashers:**

**With the ROTARY SWITCH set to FLASH MODE and the ROCKER SWITCH on AUX:** Scan-Lock will operate with the flash patterns listed below.

**Available Flash Patterns - 6 & 8 Lamp Arrays (Flash Mode):** SignalAlert™75, CometFlash@75, SingleFlash 375, SingleFlash 150, ActionScan™, ActionFlash™, SingleFlash 75