

WHELEN[®]

ENGINEERING COMPANY INC.

51 Winthrop Road
Chester, Connecticut 06412-0684
Phone: (860) 526-9504
Fax: (860) 526-4078
Internet: www.whelen.com
Sales e-mail: autosale@whelen.com
Canadian Sales e-mail: canadiansales@whelen.com
Customer Service e-mail: custserv@whelen.com

Installation Guide: L53 LED Beacon

Safety First

This document provides all the necessary information to allow your Whelen product to be properly and safely installed. Before beginning the installation and/or operation of your new product, the installation technician and operator must read this manual completely. Important information is contained herein that could prevent serious injury or damage.

- **Proper installation of this product requires the installer to have a good understanding of automotive electronics, systems and procedures.**
- **Failure to use specified installation parts and/or hardware will void the product warranty!**
- **If mounting this product requires drilling holes, the installer MUST be sure that no vehicle components or other vital parts could be damaged by the drilling process. Check both sides of the mounting surface before drilling begins. Also de-burr the holes and remove any metal shards or remnants. Install grommets into all wire passage holes.**
- **If this manual states that this product may be mounted with suction cups, magnets, tape or Velcro®, clean the mounting surface with a 50/50 mix of isopropyl alcohol and water and dry thoroughly.**
- **Do not install this product or route any wires in the deployment area of your air bag. Equipment mounted or located in the air bag deployment area will damage or reduce the effectiveness of the air bag, or become a projectile that could cause serious personal injury or death. Refer to your vehicle owner's manual for the air bag deployment area. The User/Installer assumes full responsibility to determine proper mounting location, based on providing ultimate safety to all passengers inside the vehicle.**
- **For this product to operate at optimum efficiency, a good electrical connection to chassis ground must be made. The recommended procedure requires the product ground wire to be connected directly to the NEGATIVE (-) battery post (this does not include products that use cigar power cords).**
- **If this product uses a remote device for activation or control, make sure that this device is located in an area that allows both the vehicle and the device to be operated safely in any driving condition.**
- **Do not attempt to activate or control this device in a hazardous driving situation.**
- **This product contains either strobe light(s), halogen light(s), high-intensity LEDs or a combination of these lights. Do not stare directly into these lights. Momentary blindness and/or eye damage could result.**
- **Use only soap and water to clean the outer lens. Use of other chemicals could result in premature lens cracking (crazing) and discoloration. Lenses in this condition have significantly reduced effectiveness and should be replaced immediately. Inspect and operate this product regularly to confirm its proper operation and mounting condition. Do not use a pressure washer to clean this product.**
- **It is recommended that these instructions be stored in a safe place and referred to when performing maintenance and/or reinstallation of this product.**
- **FAILURE TO FOLLOW THESE SAFETY PRECAUTIONS AND INSTRUCTIONS COULD RESULT IN DAMAGE TO THE PRODUCT OR VEHICLE AND/OR SERIOUS INJURY TO YOU AND YOUR PASSENGERS!**

For warranty information regarding this product, visit www.whelen.com/warranty

Mounting:

The L53 beacon is available in Permanent mount, Magnetic mount and mirror mount. The L53 beacon is designed to be mounted in a normal dome-up position.

WARNING! All customer supplied wires that connect to the positive terminal of the battery must be sized to supply at least 125% of the maximum operating current and FUSED at the battery to carry that load. DO NOT USE CIRCUIT BREAKERS WITH THIS PRODUCT!

Permanent mount:

1. Position the beacon in its mounting location (refer to warnings on page 1).
2. Locate the 3 mounting holes on the bottom of the base. Using the base as a template, mark the location of these holes onto the mounting surface. Remove the beacon and make a mark in the center of the beacons mounted position for a wire passage hole.
3. Using a #16 drill bit, drill the three mounting holes marked in the previous step. The wire access hole should be drilled using a 3/8" drill bit. Deburr all holes and install the rubber grommet (supplied) to protect the wires.
4. Position the mounting gasket onto the mounting surface so that the gasket holes are aligned with the mounting holes.
5. Feed the wires through the wire access hole in the mounting surface.
6. Align base with mounting holes and secure with #10 sheet metal screws.

Wire Function:

Color	Function	Connect to:	Switch Type	Fuse @
COLOR of LED*	Power	+12 or 24 VDC	SP/ST	1 Amp
BLACK	Ground	Chassis Ground	N/A	N/A

*Wire will be the same color the LED in the beacon is (RED, AMBER, BLUE or WHITE).

Magnetic Mount:

Place the beacon on any flat metal surface and plug the cigar cord into the vehicles cigar lighter. The beacon is controlled with the On/Off cigar cord switch.

IMPORTANT! The use of any magnetically mounted warning beacon on the outside of a vehicle while in motion is not recommended and is at the sole discretion and responsibility of the user.

Mirror Mount Bracket

1. Secure the Beacon to the bracket using the supplied sheet metal screws and elastic stop nuts.
2. Secure the bracket to the mirror or other part of the vehicle using the two supplied U-Bolts and elastic stop nuts.

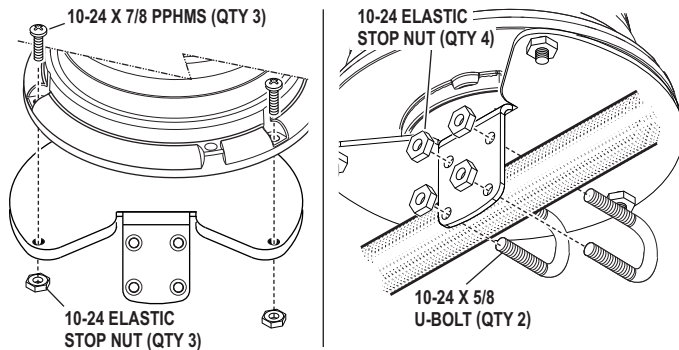

Scan-Lock™

Unscrew and remove the lens from the base. With the beacon active, to cycle forward through the patterns short the two solder pads (shown below) for less than 1 second. More than a second causes the beacon to cycle backwards through the patterns. To reset to the factory default pattern turn off the beacon, and with the solder pads shorted out, activate the beacon.

Flash Patterns:

- | | | |
|---------------------|--------------------|-----------------------------|
| 1. SignalAlert™ 75 | 6. DoubleFlash 150 | 11. ComAlert™ |
| 2. SignalAlert™ 150 | 7. DoubleFlash 75 | 12. ActionScan™ |
| 3. SingleFlash 375 | 8. CometFlash® | 13. SignalAlert™ Steady |
| 4. SingleFlash 150 | 9. ActionFlash™ | 14. Steady (high intensity) |
| 5. SingleFlash 75 | 10. ModuFlash™ | 15. Steady (low intensity) |

IMPORTANT! It is the responsibility of the installation technician to make sure that the installation and operation of this product will not interfere with or compromise the operation or efficiency of any vehicle equipment! Before returning the vehicle to active service, visually confirm the proper operation of this product, as well as all vehicle components/equipment.

PERM. MOUNT 12 or 24 VOLT

MAG. MOUNT

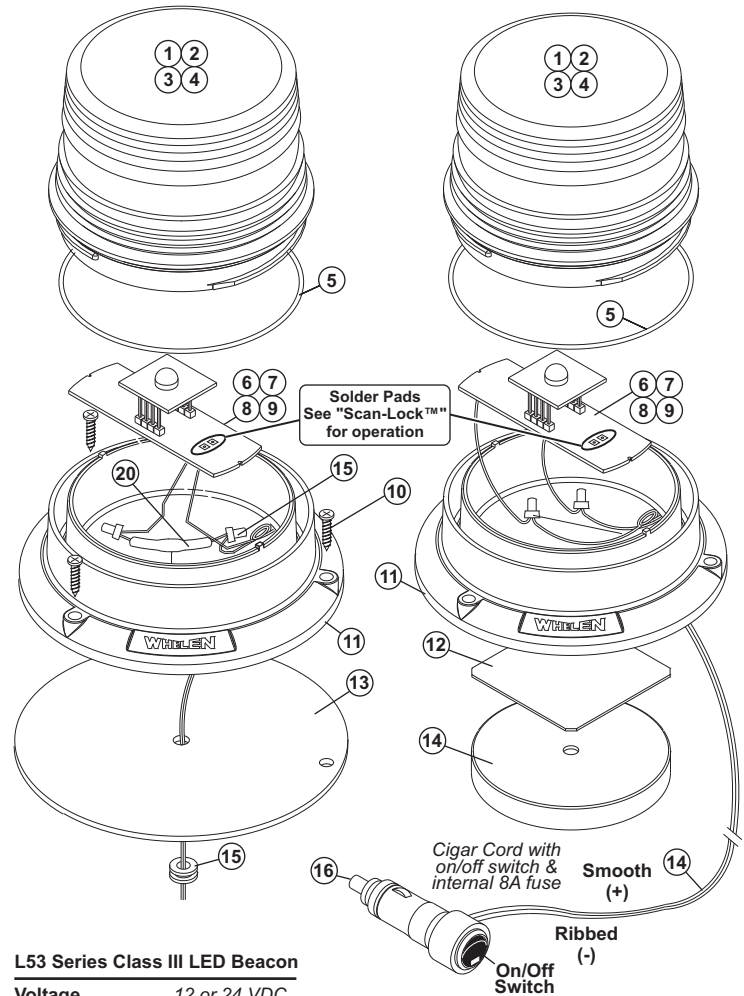

L53 Series Class III LED Beacon

Voltage12 or 24 VDC
 Current400mA (max.) / 160mA (avg.)
 Default Pattern SignalAlert™ 75

PART NUMBER KEY :

01-0685960-

VOLTAGE
 - = 12 V
 2 = 24V

LEADING
 COLOR
 VOLTAGE

LED/DOME

COLOR
 A = AMBER
 B = BLUE
 C = CLEAR
 R = RED

MOUNTING

P = PERMANENT
 M = MAGNETIC

IMPORTANT WARNING!

CAUTION! DO NOT LOOK DIRECTLY AT THESE LED'S WHILE THEY ARE ON. MOMENTARY BLINDNESS AND/OR EYE DAMAGE COULD RESULT!

QTY	QTY	QTY	ITEM	PART NUMBER	DESCRIPTION
	*			01-0685960-__P	CLASS 3 BEACON L53 SERIES / PERM MNT / 12V
	*			01-0685960-__M	CLASS 3 BEACON L53 SERIES / MAG MNT / 12V
*				01-06859602__P	CLASS 3 BEACON L53 SERIES / PERM MNT / 24V
1	1	1	1	11-383506-001	BASE / MID-SIZE BEACON / WHELEN LOGO
1	1	1	2	68-1983507-10	LENS / MID-SIZE BEACON / AMBER
AR	AR	AR	3	68-1983507-20	LENS / MID-SIZE BEACON / BLUE
AR	AR	AR	4	68-1983507-30	LENS / MID-SIZE BEACON / CLEAR
AR	AR	AR	5	68-1983507-50	LENS / MID-SIZE BEACON / RED
1	1	1	6	02-0169812-10	PCB ASSY BALLAST CLASS 3 LED BEACON / AMBER
AR	AR	AR	7	02-0169812-20	PCB ASSY BALLAST CLASS 3 LED BEACON / BLUE
AR	AR	AR	8	02-0169812-30	PCB ASSY BALLAST CLASS 3 LED BEACON / WHITE
AR	AR	AR	9	02-0169812-50	PCB ASSY BALLAST CLASS 3 LED BEACON / RED
1	1	1	10	10-0526128-__	LABEL / WHELEN MODEL VOLTAGE L53 SERIES
1	1	1	11	38-0417044-00	O-RING
-	1	-	12	65-0010192-00	MAGNET / 90# PULL
-	1	-	13	66-0421273-00	DOUBLE-SIDED TAPE
-	1	-	14	69-1317241-00	CORD / CIG. PLUG STRT. 10' 18GA ON/OFF SWITCH 8A FUSE
2	2	-	15	25-0910223-03	BUTT TERMINAL
-	1	-	16	10-0322783-02	LABEL / AIRBAG & MAG MOUNT WARNING
3	-	3	17	15-101416-160	#10 PPHSMS 1"
1	-	1	18	21-11091202-0	3/8" GROMMET
1	-	1	19	38-0222777-00	GASKET
1	-	-	20	01-0243260-00	ASSY 24V TO 12V CONVERTER
1	1	1	21	10-0323283-03	LABEL / MODEL L53 SERIES