

# WHELEN<sup>®</sup>

## ENGINEERING COMPANY INC.

51 Winthrop Road  
Chester, Connecticut 06412-0684  
Phone: (860) 526-9504  
Fax: (860) 526-4078  
Internet: [www.whelen.com](http://www.whelen.com)  
Sales e-mail: [autosale@whelen.com](mailto:autosale@whelen.com)  
Canadian Sales e-mail: [canadiansales@whelen.com](mailto:canadiansales@whelen.com)  
Customer Service e-mail: [custserv@whelen.com](mailto:custserv@whelen.com)

**Installation/Operating Guide:**  
**Dual Siren Control Head & Amp**  
**295HFSA7 (Flush Mount)**  
**295HFSA8 (Console Mount)**

**DANGER!** Sirens produce extremely loud emergency warning tones! Exposure to these tones without proper and adequate hearing protection, could cause ear damage and/or hearing loss! The Occupational Safety & Health Administration ([www.osha.gov](http://www.osha.gov)) provides information necessary to determine safe exposure times in Occupational Noise Exposure Section 1910.95. Until you have determined the safe exposure times for your specific application, operators and anyone else in the immediate vicinity should be required to wear an approved hearing protection device. **FAILURE TO FOLLOW THIS RECOMMENDATION COULD CAUSE HEARING LOSS!**

### Warnings to Installers

Whelen's emergency vehicle warning devices must be properly mounted and wired in order to be effective and safe. Read and follow all of Whelen's written instructions when installing or using this device. Emergency vehicles are often operated under high speed stressful conditions which must be accounted for when installing all emergency warning devices. Controls should be placed within convenient reach of the operator so that they can operate the system without taking their eyes off the roadway. Emergency warning devices can require high electrical voltages and/or currents. Properly protect and use caution around live electrical connections. Grounding or shorting of electrical connections can cause high current arcing, which can cause personal injury and/or vehicle damage, including fire. Many electronic devices used in emergency vehicles can create or be affected by electromagnetic interference. Therefore, after installation of any electronic device it is necessary to test all electronic equipment simultaneously to insure that they operate free of interference from other components within the vehicle. Never power emergency warning equipment from the same circuit or share the same grounding circuit with radio communication equipment. All devices should be mounted in accordance with the manufacturer's instructions and securely fastened to vehicle elements of sufficient strength to withstand the forces applied to the device. Driver and/or passenger air bags (SRS) will affect the way equipment should be mounted. This device should be mounted by permanent installation and within the zones specified by the vehicle manufacturer, if any. Any device mounted in the deployment area of an air bag will damage or reduce the effectiveness of the air bag and may damage or dislodge the device. Installer must be sure that this device, its mounting hardware and electrical supply wiring does not interfere with the air bag or the SRS wiring or sensors. Mounting the unit inside the vehicle by a method other than permanent installation is not recommended as unit may become dislodged during swerving; sudden braking or collision. Failure to follow instructions can result in personal injury. Whelen assumes no liability for any loss resulting from the use of this warning device. **PROPER INSTALLATION COMBINED WITH OPERATOR TRAINING IN THE PROPER USE OF EMERGENCY WARNING DEVICES IS ESSENTIAL TO INSURE THE SAFETY OF EMERGENCY PERSONNEL AND THE PUBLIC.**

### Warnings to Users

Whelen's emergency vehicle warning devices are intended to alert other operators and pedestrians to the presence and operation of emergency vehicles and personnel. However, the use of this or any other Whelen emergency warning device does not guarantee that you will have the right-of-way or that other drivers and pedestrians will properly heed an emergency warning signal. Never assume you have the right-of-way. It is your responsibility to proceed safely before entering an intersection, driving against traffic, responding at a high rate of speed, or walking on or around traffic lanes. Emergency vehicle warning devices should be tested on a daily basis to ensure that they operate properly. When in actual use, the operator must ensure that both visual and audible warnings are not blocked by vehicle components (i.e.: open trunks or compartment doors), people, vehicles, or other obstructions. It is the user's responsibility to understand and obey all laws regarding emergency warning devices. The user should be familiar with all applicable laws and regulations prior to the use of any emergency vehicle warning device. Whelen's audible warning devices are designed to project sound in a forward direction away from the vehicle occupants. However, because sustained periodic exposure to loud sounds can cause hearing loss, all audible warning devices should be installed and operated in accordance with the standards established by the National Fire Protection Association.

### Safety First

This document provides all the necessary information to allow your Whelen product to be properly and safely installed. Before beginning the installation and/or operation of your new product, the installation technician and operator must read this manual completely. Important information is contained herein that could prevent serious injury or damage.

- **Proper installation of this product requires the installer to have a good understanding of automotive electronics, systems and procedures.**
- **Whelen Engineering requires the use of waterproof butt splices and/or connectors if that connector could be exposed to moisture.**
- **Failure to use specified installation parts and/or hardware will void the product warranty.**
- **If mounting this product requires drilling holes, the installer MUST be sure that no vehicle components or other vital parts could be damaged by the drilling process. Check both sides of the mounting surface before drilling begins. Also de-burr the holes and remove any metal shards or remnants. Install grommets into all wire passage holes.**
- **If this manual states that this product may be mounted with suction cups, magnets, tape or Velcro®, clean the mounting surface with a 50/50 mix of isopropyl alcohol and water and dry thoroughly.**
- **Do not install this product or route any wires in the deployment area of your air bag. Equipment mounted or located in the air bag deployment area will damage or reduce the effectiveness of the air bag, or become a projectile that could cause serious personal injury or death. Refer to your vehicle owner's manual for the air bag deployment area. The User/Installer assumes full responsibility to determine proper mounting location, based on providing ultimate safety to all passengers inside the vehicle.**
- **For this product to operate at optimum efficiency, a good electrical connection to chassis ground must be made. The recommended procedure requires the product ground wire to be connected directly to the NEGATIVE (-) battery post (this does not include products that use cigar power cords).**
- **If this product uses a remote device for activation or control, make sure that this device is located in an area that allows both the vehicle and the device to be operated safely in any driving condition.**
- **It is recommended that these instructions be stored in a safe place and referred to when performing maintenance and/or reinstallation of this product.**
- **FAILURE TO FOLLOW THESE SAFETY PRECAUTIONS AND INSTRUCTIONS COULD RESULT IN DAMAGE TO THE PRODUCT OR VEHICLE AND/OR SERIOUS INJURY TO YOU AND YOUR PASSENGERS!**

**ACTIVATION OF THIS  
SIREN MAY DAMAGE  
UNPROTECTED EARS!**



**CAUTION**  
Loud siren noise can cause hearing damage and/or loss. Refer to OSHA Section 1910.95 prior to putting ANY siren into service!

**Congratulations** on selecting the 295HFSA7 / 295HFSA8 Siren! This product offers a unique and distinctive collection of features designed to allow the user to customize the operation of this siren to suit their individual wants or needs.

- 9 Programmable operating profiles
- Switch or ignition activated panel illumination.
- Stereo (dual) or mono sound control.
- 200 Watts of output power.
- Removable microphone.
- Hands-Free operation.
- Radio Repeat.
- Simulated mechanical siren tones.
- Harmonically-rich, composite Airhorn tones.
- Title 13-compliant profiles.
- Independent, non-destructive short circuit protection.

## Installation: Control Head

**Important:** Mounting will require drilling. It is absolutely necessary to make sure that no vehicle components behind the mounting area will be damaged. If damage is possible, Select another location.

**Installation:** There are two mounting styles for the siren control head depending on the model purchased.

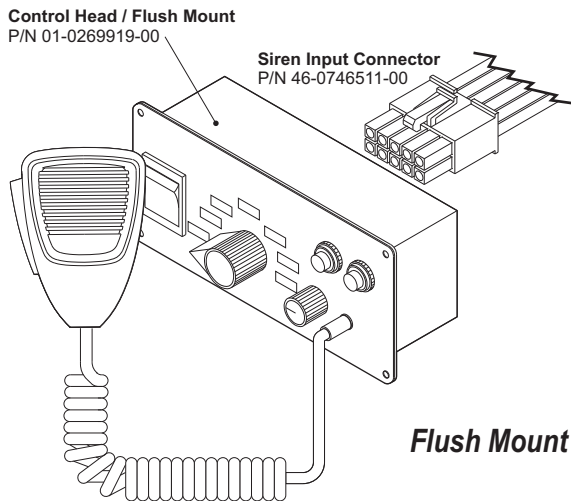

**Flush Mount:** The flush mount unit can be mounted in a console or other location. Using the measurements below, cut the hole for the control head, then slide the unit in. Mark and drill the four mounting holes for the customer supplied mounting hardware.

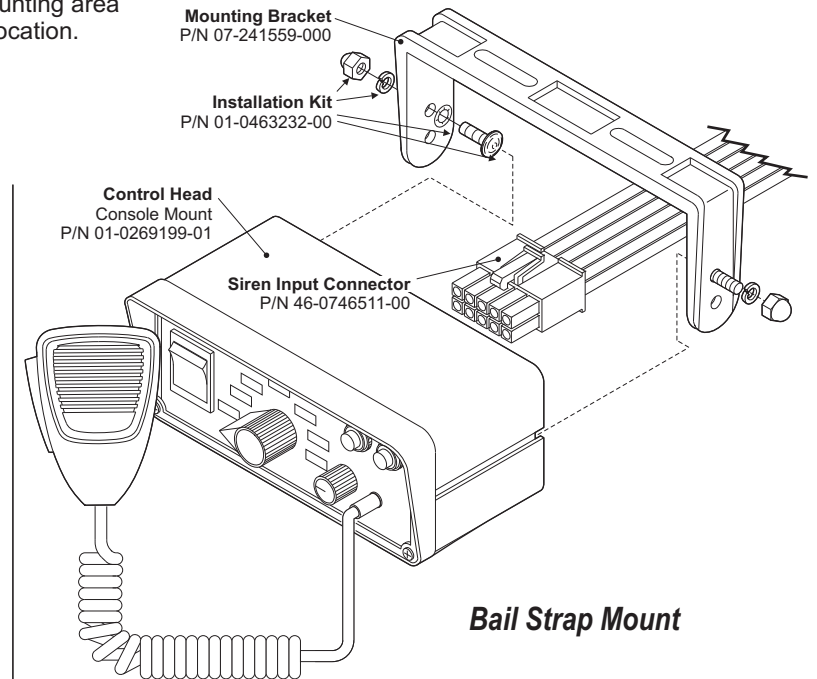

**Bail Strap Mount:** This unit uses a bail strap that can be attached under the dash. Follow the diagram above for assembly of the bracket. You will need to supply the screws that attach the bracket to the vehicle.

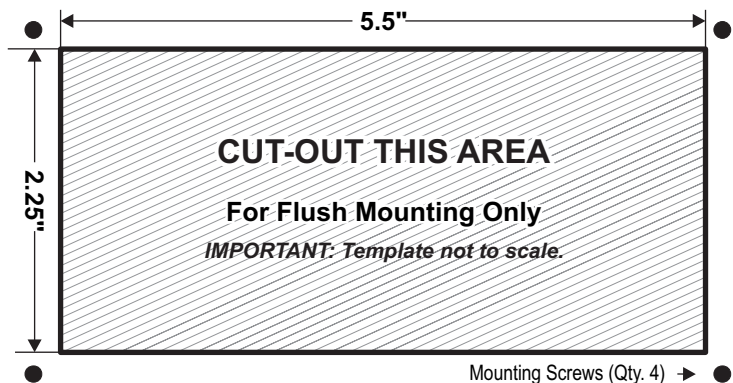
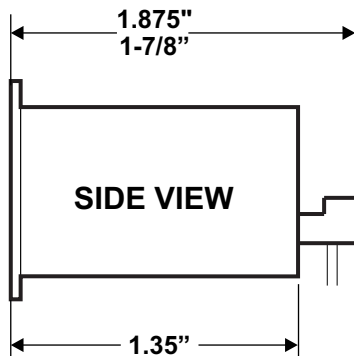

## Installation: Amplifier

1. Locate a suitable mounting location for the amplifier. The vertical wall between the trunk and the passenger compartment is often a good choice and is the method discussed in this manual.
2. Be sure that the amplifier fits properly and does not interfere with any parts of the trunk lid or seat back.
3. Position the amplifier on the proposed mounting location. Using an awl or other suitable tool, scribe the mounting surface where the mounting holes are to be drilled.

**CAUTION! As mounting the amplifier will require drilling, it is absolutely necessary to make sure that no other vehicle components could be damaged by the drilling process. If any vehicle component could suffer any potential harm, select a different mounting location.**

4. Carefully drill the mounting holes using a drill bit sized for a #10 sheet metal screw.
5. Using the supplied #10 x 3/4" sheet metal screws, secure the remote amplifier to the vertical trunk wall.

## Wiring

### Connecting to Power:

1. Using appropriately sized wire, extend the RED and BLACK wires from the Main Power Connector, through the firewall and into the engine compartment (refer to the Wire Gage Calculation Chart located on the last page of this manual to determine the proper wire size for your application).
2. Follow the factory wiring harness towards your vehicle's battery.

**WARNING! All customer supplied wires that connect to the positive terminal of the battery must be sized to supply at least 125% of the maximum operating current and FUSED at the battery to carry that load. DO NOT USE CIRCUIT BREAKERS WITH THIS PRODUCT!**

3. Install a user supplied 20A fuse block on the end of the RED wire. Connect the fuse block to the battery using no more than 2 feet of wire. **Do not install the fuse into the fuse holder yet!**

4. Connect the BLACK wire directly to the NEGATIVE battery terminal.

### Connecting to your Speaker(s):

1. Route the ORANGE, and BROWN wires from both Siren Connector #1 and Siren Connector #2 along the factory wiring harness towards your speakers.
2. Connect the ORANGE wire from Siren Connector #1 to the POSITIVE (+) terminal on speaker #1. Connect the ORANGE wire from Siren Connector #2 to the POSITIVE (+) terminal on speaker #2.
3. Connect the BROWN wire from Siren Connector #1 to the NEGATIVE (-) terminal on speaker #1. Connect the BROWN wire from Siren Connector #2 to the NEGATIVE (-) terminal on speaker #2.

### Hands-Free Siren (optional):

Refer to the wiring diagram for all wiring information for this optional connection.

### Radio Rebroadcast (optional):

The two (2) BLUE wires are used to connect your two-way radio's external speaker for radio rebroadcast. This is an optional connection and will not effect the other operations.

**Note: Radio rebroadcast will NOT work with amplified remote speakers! If your remote speaker is amplified (I.E.: contains a power amp circuit in the speaker assembly), do not enable the radio rebroadcast feature.**

Installation will be complete after a 20A fuse has been installed in the Main Power Connector fuse block. Now inspect the fuses at the back of the amplifier and at the battery. If either of these fuses are blown, carefully inspect all of the circuit wires and make sure they are wired correctly. Replace the blown fuses with ones of an identical amp rating. If these fuses blow after installation or activation, contact Whelen Engineering Technical Support.

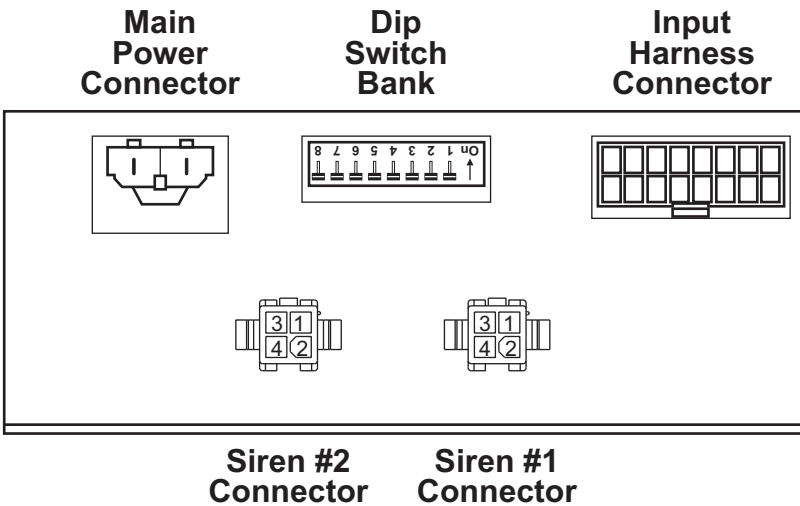

		Wire Gage (AWG)										
		22	20	18	16	14	12	10	8	6	4	2
Current Draw (AMPS)	5	6	9.5	15	24.5	39	62	98	156	248	395	629
	10	3	5	7.5	12	19.5	31	49	78	124	197	314
	15	INS.	3	5	8	13	20.5	32.5	52	82.5	131	209
	20	INS.	INS.	4	6	9.5	15.5	24.5	39	62	98.5	157
	25	INS.	INS.	3	5	8	12.5	19.5	31	49.5	79	125
	30	INS.	INS.	INS.	4	6.5	10.5	16.5	26	41.5	66	104
	35	INS.	INS.	INS.	3.5	5.5	9	14	22.5	35.5	56.5	89.5
	40	INS.	INS.	INS.	3	5	7.5	12.5	19.5	31	49.5	78.5
	45	INS.	INS.	INS.	INS.	4.5	7	11	17.5	27.5	44	69.5
	50	INS.	INS.	INS.	INS.	4	6	10	15.5	25	39.5	63
	55	INS.	INS.	INS.	INS.	3.5	5.5	9	14	22.5	36	57
	60	INS.	INS.	INS.	INS.	3	5	8	13	20.5	33	52.5
65	INS.	INS.	INS.	INS.	3	5	7.5	12	19	30.5	48.5	
70	INS.	INS.	INS.	INS.	3	4.5	7	11	17.5	28	45	
75	INS.	INS.	INS.	INS.	INS.	4	6.5	10.5	16.5	26.5	42	
80	INS.	INS.	INS.	INS.	INS.	4	6	10	15.5	24.5	39	
85	INS.	INS.	INS.	INS.	INS.	3.5	6	9	14.5	23	37	
90	INS.	INS.	INS.	INS.	INS.	3.5	5.5	8.5	14	22	35	
95	INS.	INS.	INS.	INS.	INS.	3.5	5	8	13	21	33	
100	INS.	INS.	INS.	INS.	INS.	3	5	8	12.5	19.5	31.5	

INS. = Insufficient All Distances Shown Are In Feet

### Wire Gauge Calculation Chart

1. Determine the amount of current being drawn through the wire. Locate this number in the vertical left-hand column. If the current value is between adjacent values, use the higher number.
2. Follow this row until the length of the installed wire is shown. If the exact length is between adjacent values, use the higher number. Follow this column upwards to find the recommended size (gauge) for this wire.

# Wiring Diagram

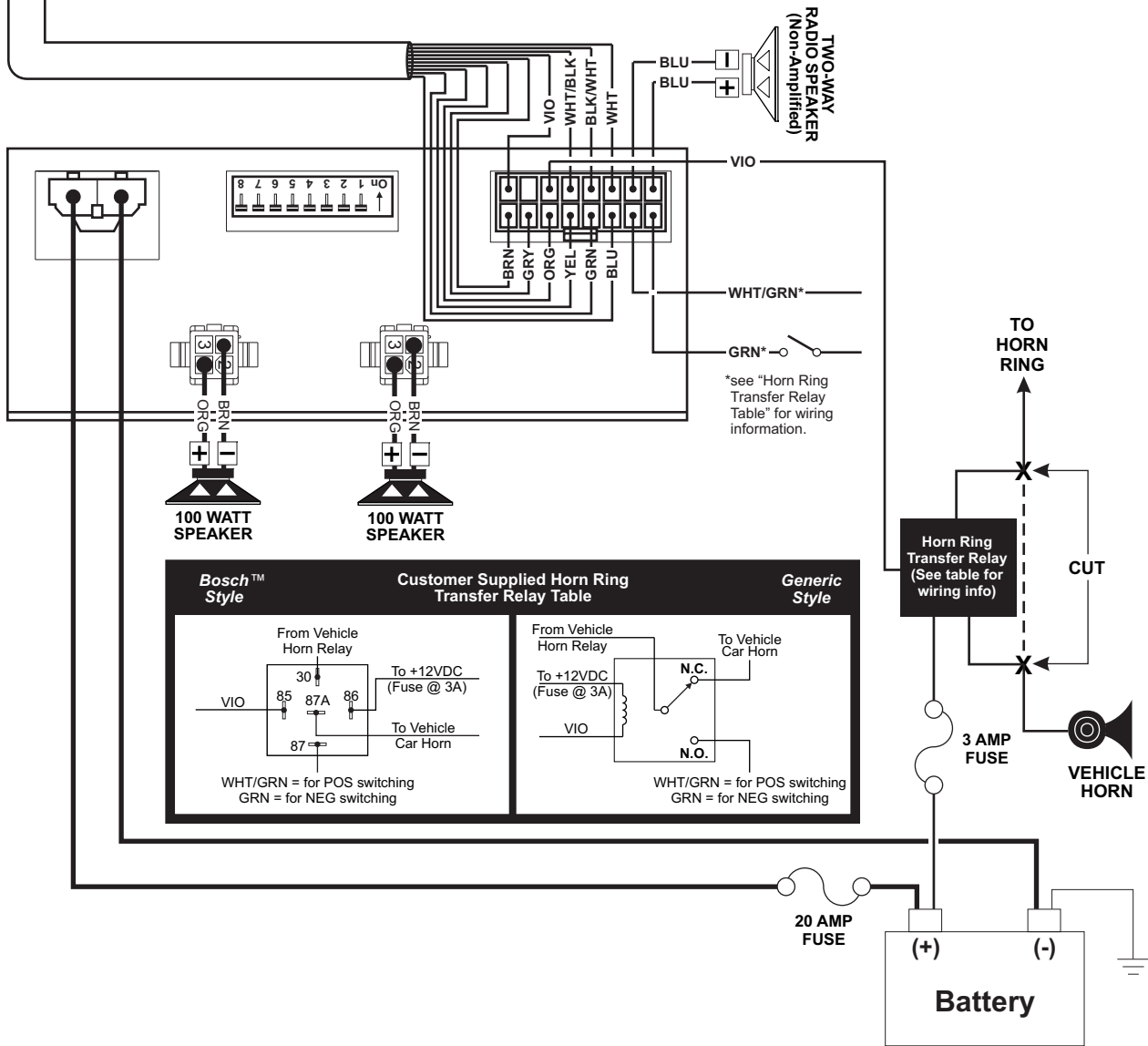
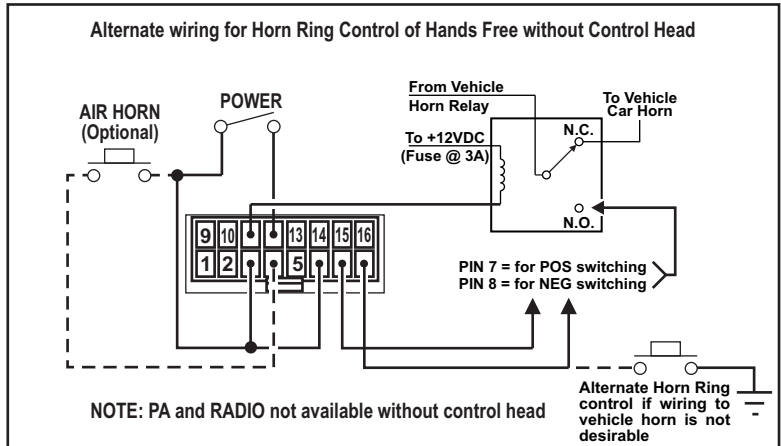
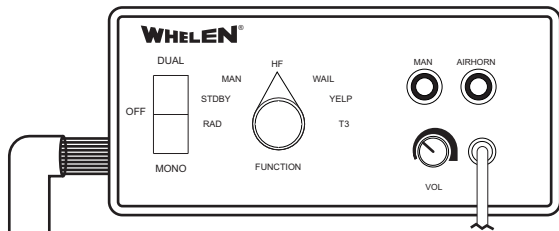

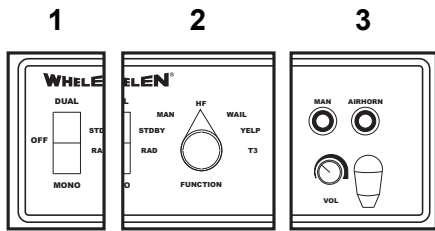

## Operating the Controls:

### Power Switch (1)

This switch has three positions. Center (Off), Down (On/Mono) & Up (On/Stereo). When this switch is Off, the unit will not function. When the switch is in either On position, the siren is functional and may be activated at the operator's discretion.

### Rotary Knob (2)

The Rotary Knob controls the siren functions. There are 7 positions that may be selected. Each position and its function is outlined under "Rotary Switch Operations".

### Volume Knob, Man Button and Horn Button (3)

The Volume Knob controls the volume of public address function. Volume is increased by rotating the knob in a clockwise direction. Rotating the volume knob in a counter-clockwise direction decreases volume. The volume knob has no effect on any siren tones produced.

The Manual Button generates a variety of tones, depending on what position the rotary knob is in. For further explanation of this button's function, refer to "Rotary Switch Operations."

Holding the AIRHORN button on, generates an AIRHORN tone whenever the siren is powered up.

## Rotary Switch Operations:

**Note:** This section assumes the horn ring circuit has been wired as shown on Page 4.

**RAD (Radio Repeat)** - When the rotary knob is in the RAD position, any signal that is received by the vehicle's two-way radio will be simultaneously broadcast over the vehicle's loudspeaker (unit must be connected to the two-way radio as outlined in this manual).

### With the Rotary Switch in the RAD Position:

- Activating the HORN RING will activate the VEHICLE HORN until the HORN RING is released.
- Pressing the AIRHORN button will result in an AIRHORN tone until the AIRHORN button is released.
- Pressing the MAN button results in the AIRHORN tone until the MAN button is released.

**STDBY (Manual Siren)** - When the rotary switch is in this position the siren is in a standby state where no tones have been activated, but is waiting for another action to be taken by the operator. This position is often the best choice when manual operation of the siren is desired.

### With the Rotary Switch in the STDBY Position:

- Activating the HORN RING will produce a AIR HORN tone until the HORN RING input is released.
- Pressing the AIRHORN button will result in the AIRHORN tone until the AIRHORN button is released.
- Pressing the MAN button will result in the Manual Wail tone ramping up to peak frequency and ramping down when the MAN button is released.

**MAN (Manual Siren)** - When the rotary switch is in this position the siren is in a standby state where no tones have been activated, but is waiting for another action to be taken by the operator. This position is used when manual operation of the siren is desired.

### With the Rotary Switch in the MAN Position:

- Activating the HORN RING will result in a Manual Wail tone ramping up to the peak frequency and stopping when the HORN RING input is released.
- Pressing the AIRHORN button produces an AIRHORN tone until the AIRHORN button is released.
- Pressing the MAN button has the same effect as pressing the HORN RING.

**HF (Hands-Free Operation)** - When the rotary knob is in the HF position, the siren functions are placed in a standby mode. Siren tones are activated by a single "tap" on the MAN button or on the vehicle's steering wheel horn ring (if the vehicle's horn has been wired to the HORN RING input). The first tap produces Wail. A second tap produces Yelp. A third tap produces Tone 3. The next tap returns the siren to Wail and the cycle

repeats itself. Two quick successive taps will stop the siren (refer to the tables on the following pages for hands-free tonal information).

### With the Rotary Switch in the HF Position:

- Activating the HORN RING will result in the HF cycle as described above.
- Pressing the AIRHORN button will result in the AIRHORN tone until the AIRHORN button is released.
- Pressing the MAN button will result in the HF cycle as described above.

**WAIL (Wail Tone)** - When the rotary knob is in the WAIL position, a steady, rise and fall wail tone is produced.

### With the Rotary Switch in the WAIL Position:

- Activating the HORN RING will change the siren tone to the override tone. Activating the HORN RING a second time returns it back to a WAIL.
- Pressing the AIRHORN button will result in an AIRHORN tone until the AIRHORN button is released.
- Pressing the MAN button will change the siren tone to the override tone. Pressing the MAN button again returns it back to a WAIL.

**YELP (Yelp Tone)** - When the rotary knob is in the YELP position, a fast, rise and fall tone is produced.

### With the Rotary Switch in the YELP Position:

- Activating the HORN RING will change the siren tone to the override tone. Activating the HORN RING a second time returns it back to a YELP tone.
- Pressing the AIRHORN button will result in the AIRHORN tone until the AIRHORN button is released.
- Pressing the MAN button will change the siren tone to the override tone. Pressing the MAN button a second time returns it back to a YELP tone.

**T3 (Piercer™ Tone (see dip switch tables))** - When the rotary knob is in the T3 position, an extremely fast, rise and fall tone is produced.

### With the Rotary Switch in the T3 Position:

- Activating the HORN RING will produce the override tone until the HORN RING is released.
- Pressing the AIRHORN button will result in an AIRHORN tone until the AIRHORN button is released.
- Pressing the MAN button will produce the override tone until the MAN button is released.

**Refer to the siren tables on the following pages for override tone details.**

**MICROPHONE** - Whenever the unit is powered on, activating the microphone (pressing the switch on the side of the mic.) will shut down any other siren functions & enable public address operation regardless of the rotary switch position or any other switch or input.



**Dip Switch Pos.**

**Profile 1  
T3 =  
Piercer™**

#1	#2	#3	#4
OFF	OFF	OFF	OFF

NOTE: With the power switch in "Mono" mode, Speakers 1 & 2 produce Speaker #1 tones simultaneously. In "Dual" mode, Speakers 1 & 2 operate as outlined in the following tables.

Rotary Switch	Operation: Speaker #1 / Speaker #2	MAN button: Speaker #1 / Speaker #2	Horn Ring: Speaker #1 / Speaker #2
RAD	Radio / Radio	AIRHORN / AIRHORN	AIRHORN / AIRHORN
STDBY	STDBY / STDBY	MAN / MAN (Coast to stop)	AIRHORN / AIRHORN
MAN	STDBY / STDBY	MAN / MAN (Stop)	MAN / MAN (Stop)
HF	STDBY / STDBY	WAIL / WAIL YELP / YELP PIER / PIER	WAIL / WAIL YELP / YELP PIER / PIER
WAIL	WAIL / WAIL	YELP / YELP	YELP / YELP
YELP	YELP / YELP	PIER / PIER	PIER / PIER
T3	PIER / PIER	AIRHORN / PIER	AIRHORN / PIER

**Profile 5 - T3 =  
Title 13 (Y-249)\*\***

#1	#2	#3	#4
OFF	OFF	ON	OFF

**Dip Switch Pos.**

Rotary Switch	Operation: Speaker #1 / Speaker #2	MAN button: Speaker #1 / Speaker #2	Horn Ring: Speaker #1 / Speaker #2
RAD	Radio / Radio	AIRHORN / AIRHORN	AIRHORN / AIRHORN
STDBY	STDBY / STDBY	MAN / MAN (Coast to stop)	AIRHORN / AIRHORN
MAN	STDBY / STDBY	MAN / MAN (Stop)	MAN / MAN (Stop)
HF	STDBY / STDBY	WAIL / WAIL YELP / YELP	WAIL / WAIL YELP / YELP
WAIL	WAIL / WAIL	YELP / WAIL	YELP / WAIL
YELP	YELP / YELP	Y-249 / YELP	Y-249 / YELP
T3	Y-249 / Y-249	YELP / Y-249	YELP / Y-249

\*\* a tone designed for compliance with California Title 13

**Profile 2**

#1	#2	#3	#4
ON	OFF	OFF	OFF

**Dip Switch Pos.**

Rotary Switch	Operation: Speaker #1 / Speaker #2	MAN button: Speaker #1 / Speaker #2	Horn Ring: Speaker #1 / Speaker #2
RAD	Radio / Radio	AIRHORN / AIRHORN	AIRHORN / AIRHORN
STDBY	STDBY / STDBY	MAN / MAN (Coast to stop)	AIRHORN / AIRHORN
MAN	STDBY / STDBY	MAN / MAN (Stop)	MAN / MAN (Stop)
HF	STDBY / STDBY	WAIL / WAIL YELP / WAIL PIER / YELP	WAIL / WAIL YELP / WAIL PIER / YELP
WAIL	WAIL / WAIL	YELP / WAIL	YELP / WAIL
YELP	YELP / WAIL	PIER / YELP	PIER / YELP
T3	PIER / YELP	AIRHORN / PIER	AIRHORN / PIER

**Profile 6  
(Title 13 / Mechanical)**

#1	#2	#3	#4
ON	OFF	ON	OFF

**Dip Switch Pos.**

Rotary Switch	Operation: Speaker #1 / Speaker #2	MAN button: Speaker #1 / Speaker #2	Horn Ring: Speaker #1 / Speaker #2
RAD	Radio / Radio	AIRHORN / AIRHORN	AIRHORN / AIRHORN
STDBY	STDBY / STDBY	MECH / MECH (Coast to stop)	AIRHORN / AIRHORN
MAN	STDBY / STDBY	MAN / MECH (Stop)	MAN / MECH (Stop)
HF	STDBY / STDBY	WAIL / MECH YELP / MECH	WAIL / MECH YELP / MECH
WAIL	WAIL / MECH*	YELP / MECH	YELP / MECH
YELP	YELP / MECH	Y-249 / MECH	Y-249 / MECH
T3	Y-249 / MECH	Y-249 / MECH	AIRHORN / AIRHORN

\*MECH = Simulated Mechanical Tone

**Profile 3**

#1	#2	#3	#4
OFF	ON	OFF	OFF

**Dip Switch Pos.**

Rotary Switch	Operation: Speaker #1 / Speaker #2	MAN button: Speaker #1 / Speaker #2	Horn Ring: Speaker #1 / Speaker #2
RAD	Radio / Radio	AIRHORN / AIRHORN	AIRHORN / AIRHORN
STDBY	STDBY / STDBY	MECH / MECH (Coast to stop)	AIRHORN / AIRHORN
MAN	STDBY / STDBY	MECH / MECH (Coast to stop)	MAN / MECH (Coast to stop)
HF	STDBY / STDBY	WAIL / MECH YELP / MECH PIER / MECH	WAIL / MECH YELP / MECH PIER / MECH
WAIL	WAIL / MECH*	YELP / MECH	YELP / MECH
YELP	YELP / MECH	PIER / MECH	PIER / MECH
T3	PIER / MECH	AIRHORN / MECH	AIRHORN / MECH

\*MECH = Simulated Mechanical Tone

**Profile 7**

#1	#2	#3	#4
OFF	ON	ON	OFF

**Dip Switch Pos.**

Rotary Switch	Operation: Speaker #1 / Speaker #2	MAN button: Speaker #1 / Speaker #2	Horn Ring: Speaker #1 / Speaker #2
RAD	Radio / Radio	AIRHORN / AIRHORN	AIRHORN / AIRHORN
STDBY	STDBY / STDBY	MAN / MAN (Coast to stop)	AIRHORN / AIRHORN
MAN	STDBY / STDBY	MAN / MAN (Stop)	MAN / MAN (Stop)
HF	STDBY / STDBY	Whoop / Whoop Warble / Warble	Whoop / Whoop Warble / Warble
WAIL	Warble / Warble	Whoop / Warble	Whoop / Warble
YELP	Whoop / Whoop	MECH / Whoop	MECH / Whoop
T3	MECH / MECH	AIRHORN / MECH	AIRHORN / MECH

**Profile 4**

T3 = Hi/Low

#1	#2	#3	#4
ON	ON	OFF	OFF

**Dip Switch Pos.**

Rotary Switch	Operation: Speaker #1 / Speaker #2	MAN button: Speaker #1 / Speaker #2	Horn Ring: Speaker #1 / Speaker #2
RAD	Radio / Radio	AIRHORN / AIRHORN	AIRHORN / AIRHORN
STDBY	STDBY / STDBY	MAN / MAN (Coast to stop)	AIRHORN / AIRHORN
MAN	STDBY / STDBY	MAN / MAN (Stop)	MAN / MAN (Stop)
HF	STDBY / STDBY	WAIL / WAIL YELP / YELP Hi/Low / Hi/Low	WAIL / WAIL YELP / YELP Hi/Low / Hi/Low
WAIL	WAIL / WAIL	YELP / WAIL	YELP / WAIL
YELP	YELP / YELP	Hi/Low / YELP	Hi/Low / YELP
T3	Hi/Low / Hi/Low	AIRHORN / Hi/Low	AIRHORN / Hi/Low

**Profile 8**

#1	#2	#3	#4
ON	ON	ON	OFF

**Dip Switch Pos.**

Rotary Switch	Operation: Speaker #1 / Speaker #2	MAN button: Speaker #1 / Speaker #2	Horn Ring: Speaker #1 / Speaker #2
RAD	Radio / Radio	AIRHORN / AIRHORN	AIRHORN / AIRHORN
STDBY	STDBY / STDBY	MECH / MECH (Stop)	AIRHORN / AIRHORN
MAN	STDBY / STDBY	MECH / MECH (Coast to stop)	MECH / MECH (Coast to stop)
HF	STDBY / STDBY	MECH / MECH YELP / MECH PIER / MECH	MECH / MECH YELP / MECH PIER / MECH
WAIL	MECH / MECH	WAIL / MECH	WAIL / MECH
YELP	YELP / MECH	PIER / MECH	PIER / MECH
T3	PIER / MECH	AIRHORN / PIER	AIRHORN / PIER

**Profile 9**

#1	#2	#3	#4
OFF	OFF	OFF	ON

**Dip Switch Pos.**

Rotary Switch	Operation: Speaker #1 / Speaker #2	MAN button: Speaker #1 / Speaker #2	Horn Ring: Speaker #1 / Speaker #2
RAD	Radio / Radio	AIRHORN / AIRHORN	AIRHORN / AIRHORN
STDBY	STDBY / STDBY	MAN / MAN (Coast to stop)	AIRHORN / AIRHORN
MAN	STDBY / STDBY	MAN / MAN (Stop)	MAN / MAN (Stop)
HF	STDBY / STDBY	WAIL / WAIL YELP / YELP WAIL / YELP	WAIL / WAIL YELP / YELP WAIL / YELP
WAIL	WAIL / WAIL	YELP / YELP	YELP / YELP
YELP	YELP / YELP	PIER / PIER	PIER / PIER
T3	PIER / PIER	AIRHORN / PIER	AIRHORN / PIER