

WHELEN[®]

ENGINEERING COMPANY INC.

51 Winthrop Road
Chester, Connecticut 06412-0684
Phone: (860) 526-9504
Fax: (860) 526-4078
Internet: www.whelen.com
Sales e-mail: autosale@whelen.com
Canadian Sales e-mail: autocan@whelen.com
Customer Service e-mail: custserv@whelen.com

Installation Guide:
LED Traffic Advisor™
Model TAM83_ _

Safety First

This document provides all the necessary information to allow your Whelen product to be properly and safely installed. Before beginning the installation and/or operation of your new product, the installation technician and operator must read this manual completely. Important information is contained herein that could prevent serious injury or damage.

- **Proper installation of this product requires the installer to have a good understanding of automotive electronics, systems and procedures.**
- **If mounting this product requires drilling holes, the installer MUST be sure that no vehicle components or other vital parts could be damaged by the drilling process. Check both sides of the mounting surface before drilling begins. Also de-burr any holes and remove any metal shards or remnants. Install grommets into all wire passage holes.**
- **If this manual states that this product may be mounted with suction cups, magnets, tape or Velcro®, clean the mounting surface with a 50/50 mix of isopropyl alcohol and water and dry thoroughly.**
- **Do not install this product or route any wires in the deployment area of your air bag. Equipment mounted or located in the air bag deployment area will damage or reduce the effectiveness of the air bag, or become a projectile that could cause serious personal injury or death. Refer to your vehicle owner's manual for the air bag deployment area. The User/Installer assumes full responsibility to determine proper mounting location, based on providing ultimate safety to all passengers inside the vehicle.**
- **For this product to operate at optimum efficiency, a good electrical connection to chassis ground must be made. The recommended procedure requires the product ground wire to be connected directly to the NEGATIVE (-) battery post.**
- **If this product uses a remote device to activate or control this product, make sure that this control is located in an area that allows both the vehicle and the control to be operated safely in any driving condition.**
- **Do not attempt to activate or control this device in a hazardous driving situation.**
- **This product contains either strobe light(s), halogen light(s), high-intensity LEDs or a combination of these lights. Do not stare directly into these lights. Momentary blindness and/or eye damage could result.**
- **Use only soap and water to clean the outer lens. Use of other chemicals could result in premature lens cracking (crazing) and discoloration. Lens in this condition have significantly reduced effectiveness and should be replaced immediately. Inspect and operate this product regularly to confirm its proper operation and mounting condition. Do not use a pressure washer to clean this product.**
- **It is recommended that these instructions be stored in a safe place and referred to when performing maintenance and/or reinstallation of this product.**
- **FAILURE TO FOLLOW THESE SAFETY PRECAUTIONS AND INSTRUCTIONS COULD RESULT IN DAMAGE TO THE PRODUCT OR VEHICLE AND/OR SERIOUS INJURY TO YOU AND YOUR PASSENGERS!**

For warranty information regarding this product, visit www.whelen.com/warranty

Installation:

Note: When routing the wires, it is important to choose a path that will keep the wires away from excessive heat or any vehicle equipment that could compromise the integrity of the wires (ex. trunk lids, door jams, etc.).

WARNING! When the Traffic Advisor™ is mounted to the rear of the vehicle, the cable exit must be on the passenger side. If not, the flash pattern sequence you choose on the control head will be incorrect. For example a left flashing pattern will flash right.

1. Position the unit in its proposed mounting location to ensure that it fits properly. Draw a pencil line on the mounting surface using the top and bottom of the extrusion as a guide.
2. Two 1/4" holes are required to mount this unit. These holes may be located anywhere along the horizontal centerline of the unit, but must be centered between the upper and lower lines made in step 1. **Tip!** It's a good idea to locate the mounting holes as far apart as possible.
3. Using a 1/4" drill bit, drill a hole in each of the areas scribed in the previous step.
4. Remove the end cap without the cable and insert the two carriage bolts (included) into the extrusion as shown. Position these bolts so they may pass through the mounting holes drilled in the previous step.
5. With the unit in position, place a gasket, flat washer and elastic stop nut onto each bolt and tighten firmly.

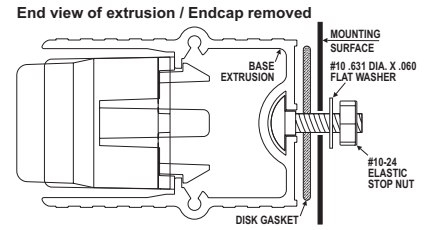
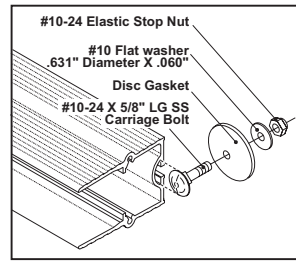

Wiring:

WARNING! All customer supplied wires that connect to the positive terminal of the battery must be sized to supply at least 125% of the maximum operating current and FUSED at the battery to carry the load. **DO NOT USE CIRCUIT BREAKERS WITH THIS PRODUCT!**

Extend the control wires to your switch panel and make the appropriate connections using the wiring information below. The control head shown in this manual is the TACTRLD1.

Note: If your system uses another control head, refer to your control head manual for connection and operation.

IMPORTANT! Before returning this vehicle to active service, visually confirm the proper operation of this product, as well as all vehicle components/equipment.

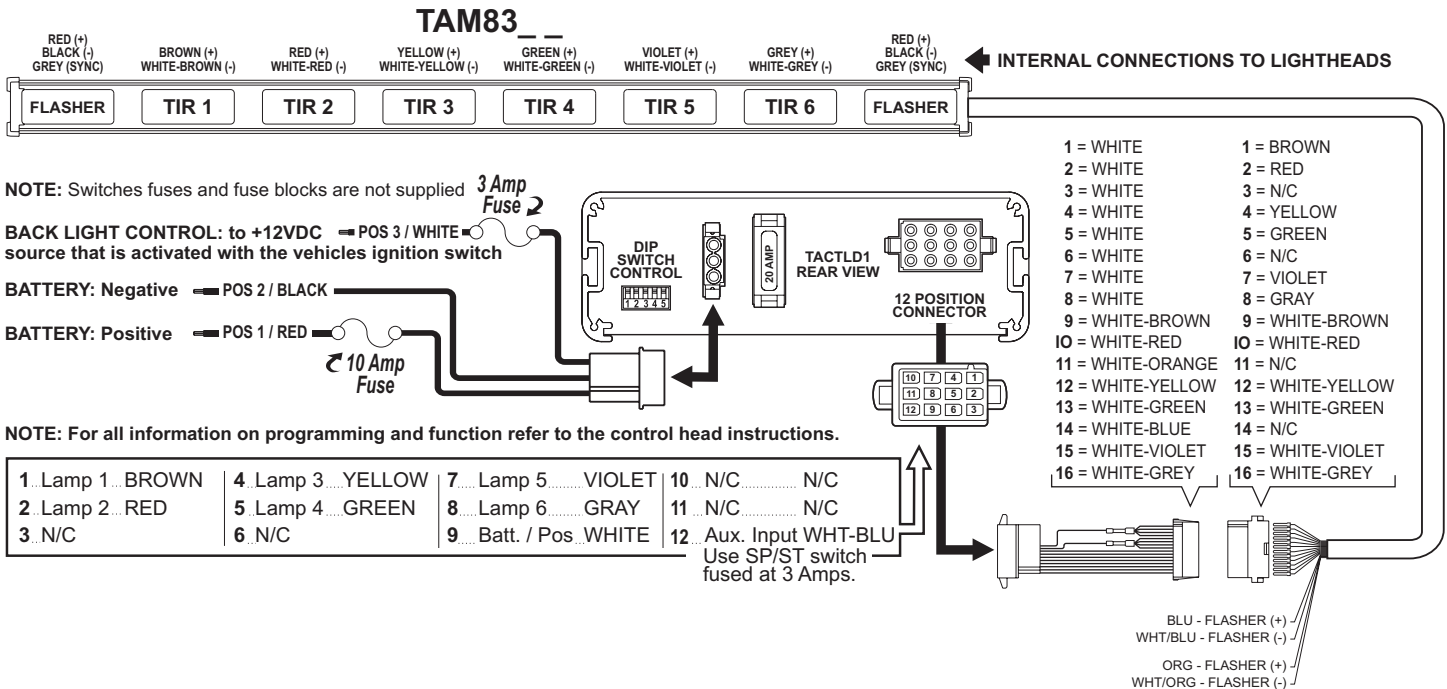

IMPORTANT WARNING!

CAUTION! DO NOT LOOK DIRECTLY AT THESE LEDS WHILE THEY ARE ON. MOMENTARY BLINDNESS AND/OR EYE DAMAGE COULD RESULT!

01-0684606

FLASHER COLOR 2
FLASHER COLOR 1
SWITCHING

FLASHER COLOR

- 1 = AMBER
- 2 = BLUE
- 3 = WHITE
- 4 = GREEN
- 5 = RED

FLASHER COLOR

- 1 = AMBER
- 2 = BLUE
- 3 = WHITE
- 4 = GREEN
- 5 = RED

SWITCHING

- 0 = SWITCHED GND.
- 1 = SWITCHED POS.
- 2 = SWITCHED GND. W/ 3RD BRAKE SPACE

QTY	QTY	QTY	ITEM	PART NUMBER	DESCRIPTION
	*			01-06846060__	T/A ASS'Y, 3TIR w/FLASHERS (switching GROUND)
	*			01-06846061__	T/A ASS'Y, 3TIR w/FLASHERS (switching POSITIVE)
*				01-06846062__	T/A ASS'Y, 3TIR w/FLASHERS & 3RD BRAKE SPACE SW GND
2	2	2	1	38-0463725-00	DIVIDER, EXTRUSION MOUNT
2	2	2	2	02-0364451612	LIGHTHEAD, 3TIR LED - STEADY
2	2	2	3	01-0264451-14	LIGHTHEAD, 3TIR LED - AMBER FLASHER
A/R	A/R	A/R	4	01-0264451-24	LIGHTHEAD, 3TIR LED - BLUE FLASHER
A/R	A/R	A/R	5	01-0264451-34	LIGHTHEAD, 3TIR LED - WHITE FLASHER
A/R	A/R	A/R	6	01-0264451-44	LIGHTHEAD, 3TIR LED - GREEN FLASHER
A/R	A/R	A/R	7	01-0264451-54	LIGHTHEAD, 3TIR LED - RED FLASHER
-	1	1	8	46-0764808-00	ASS'Y, CABLE, ENDCAP, N-F 28"
-	1	1	9	11-443031-030	EXTRUSION, - 30.00"
1	1	1	10	11-263726-000	ENDCAP, EXTRUSION MOUNT w/o HOLE
4	4	4	11	14-062219-06D	SCREW,#6-32 X 3/8" PPHMS ROLOK SS
1	1	1	12	26-0215001-03	TY-WRAP, 3"
2	2	2	13	14-104066-100	CARRIAGE BOLT, #10-24 X 5/8" LG SS
-	2	2	14	38-0223063-00	GASKET, DISK
2	2	2	15	16-1002220-50	WASHER, #10 FLAT .631" DIA. X .060"
2	2	2	16	13-104120-062	NUT, #10-24 ELASTIC STOP
-	1	-	17	46-0763757-00	CABLE ADAPTER, SWITCHED POS
1	-	1	18	46-0763757-01	CABLE ADAPTER, SWITCHED GND
1	1	1	19	39-0416313-04	HOUSING, PIN, 16-POS, AMP
1	1	1	20	21-11121602-0	GROMMET, 1/2" 2 X 8
1	-	-	21	11-443031-043	EXTRUSION - 43.38"
1	-	-	22	46-0764808-02	ASSY, CABLE, ENDCAP, 39"

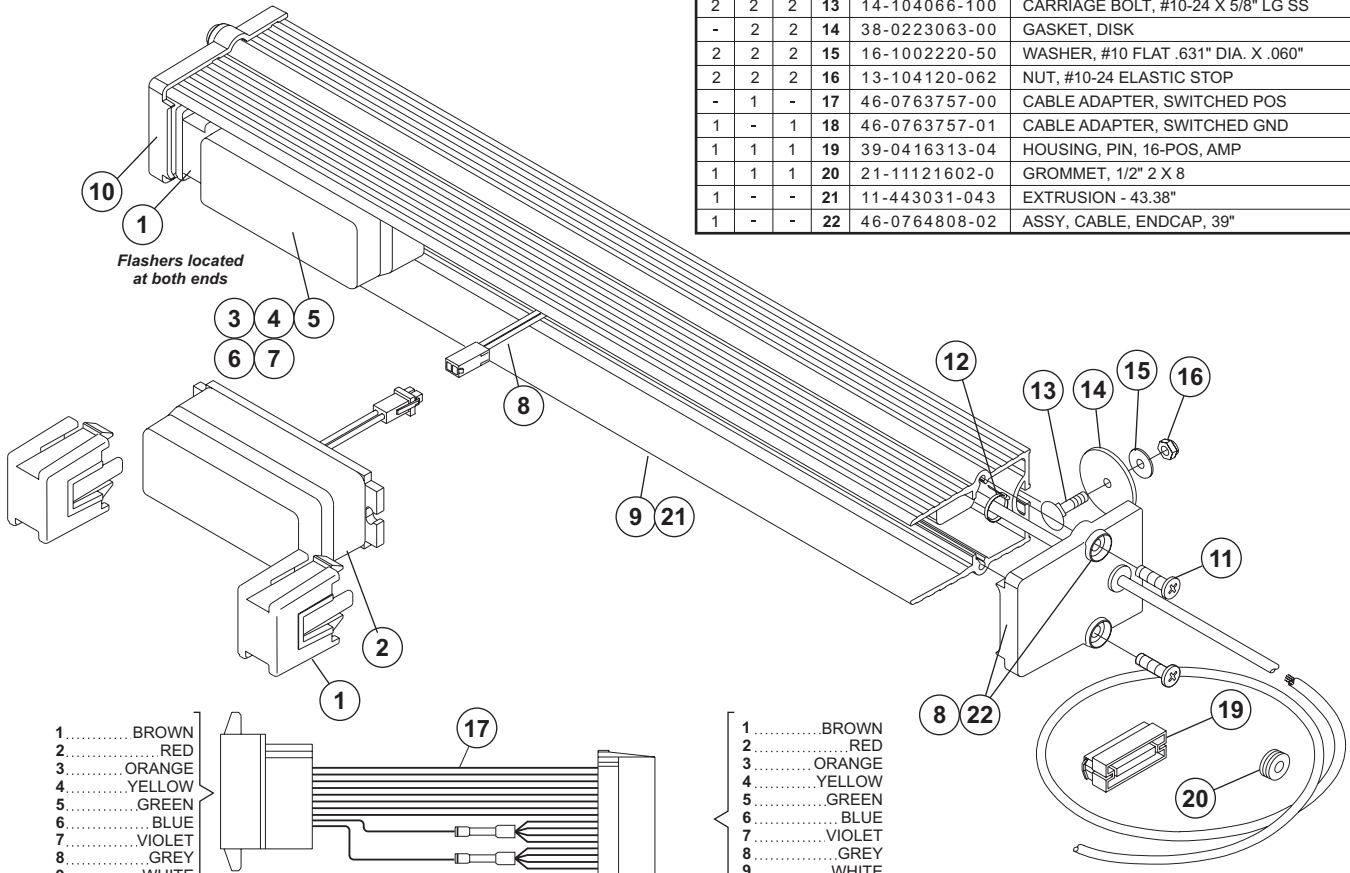

Flashers located at both ends

- 1..... BROWN
- 2..... RED
- 3..... ORANGE
- 4..... YELLOW
- 5..... GREEN
- 6..... BLUE
- 7..... VIOLET
- 8..... GREY
- 9..... WHITE
- 10..... NC
- 11..... NC
- 12..... NC

CABLE ADAPTER / POSITIVE (+) SWITCHING FOR USE WITH: SCTARM8 or SCTAREM6 CONTROL HEADS

- 1..... BROWN
- 2..... RED
- 3..... ORANGE
- 4..... YELLOW
- 5..... GREEN
- 6..... BLUE
- 7..... VIOLET
- 8..... GREY
- 9..... WHITE
- 10..... WHITE
- 11..... WHITE
- 12..... WHITE
- 13..... WHITE
- 14..... WHITE
- 15..... WHITE
- 16..... WHITE

Connector (Used with both Cable Adaptors)

- 1..... BROWN
- 2..... RED
- 3..... N/C
- 4..... YELLOW
- 5..... GREEN
- 6..... N/C
- 7..... VIOLET
- 8..... GREY
- 9..... WHITE-BROWN
- 10..... WHITE-RED
- 11..... N/C
- 12..... WHITE-YELLOW
- 13..... WHITE-GREEN
- 14..... N/C
- 15..... WHITE-VIOLET
- 16..... WHITE-GREY

- 1.. WHITE-BROWN
- 2..... WHITE-RED
- 3.. WHITE-ORANGE
- 4.. WHITE-YELLOW
- 5..... WHITE-GREEN
- 6..... WHITE-BLUE
- 7..... WHITE-VIOLET
- 8..... WHITE-GREY
- 9..... WHITE
- 10..... NC
- 11..... NC
- 12..... NC

CABLE ADAPTER / GROUND (-) SWITCHING FOR USE WITH: CENCOM, TACTRL1 or TACTLD1 CONTROL HEADS

- 1..... WHITE
- 2..... WHITE
- 3..... WHITE
- 4..... WHITE
- 5..... WHITE
- 6..... WHITE
- 7..... WHITE
- 8..... WHITE
- 9.. WHITE-BROWN
- 10..... WHITE-RED
- 11.. WHITE-ORANGE
- 12.. WHITE-YELLOW
- 13..... WHITE-GREEN
- 14..... WHITE-BLUE
- 15..... WHITE-VIOLET
- 16..... WHITE-GREY