

51 Winthrop Road
Chester, Connecticut 06412-0684
Phone: (860) 526-9504
Fax: (860) 526-4078
Sales Email: autosale@whelen.com
Canadian Sales: canadiansales@whelen.com
Customer Service: custserv@whelen.com

Safety First: This document provides all the necessary information to allow your Whelen product to be properly and safely installed. Before beginning the installation and/or operation of your new product, the installation technician and operator must read this manual completely. Important information is contained herein that could prevent serious injury or damage.

- Proper installation of this product requires the installer to have a good understanding of automotive electronics, systems and procedures.
- Whelen Engineering requires the use of waterproof butt splices and/or connectors if that connector could be exposed to moisture.
- Any holes, either created or utilized by this product, should be made both air- and watertight using a sealant recommended by your vehicle manufacturer.
- Failure to use specified installation parts and/or hardware will void the product warranty!
- If mounting this product requires drilling holes, the installer **MUST** be sure that no vehicle components or other vital parts could be damaged by the drilling process. Check both sides of the mounting surface before drilling begins. Also de-burr any holes and remove any metal shards or remnants. Install grommets into all wire passage holes.
- Do not install this product or route any wires in the deployment area of your air bag. Equipment mounted or located in the air bag deployment area will damage or reduce the effectiveness of the air bag, or become a projectile that could cause serious personal injury or death. Refer to your vehicle owner's manual for the air bag deployment area. The User/Installer assumes full responsibility to determine proper mounting location, based on providing ultimate safety to all passengers inside the vehicle.
- For this product to operate at optimum efficiency, a good electrical connection to chassis ground must be made. The recommended procedure requires the product ground wire to be connected directly to the **NEGATIVE (-)** battery post.
- If this product uses a remote device to activate or control this product, make sure that this control is located in an area that allows both the vehicle and the control to be operated safely in any driving condition.
- Do not attempt to activate or control this device in a hazardous driving situation.
- **WARNING!** All customer supplied wires that connect to the positive (+) terminal of the battery must be sized to supply at least 125% of the maximum operating current and **FUSED** "at the battery" to carry that load. **DO NOT USE CIRCUIT BREAKERS WITH THIS PRODUCT!**
- **FAILURE TO FOLLOW THESE PRECAUTIONS AND INSTRUCTIONS COULD RESULT IN DAMAGE TO THE PRODUCT OR VEHICLE AND/OR SERIOUS INJURY TO YOU AND YOUR PASSENGERS!**

Selecting a mounting location...

- Do not select a location where the unit will be exposed to potential damage from any unsecured or loose equipment in the vehicle.
 - Be sure the area selected will not allow the unit to be exposed to water!
 - When routing wires, it is important to choose a path that will keep these wires away from excessive heat and from any vehicle equipment that could compromise the integrity of the wires.
 - When the best mounting location has been determined, securely fasten the unit to it's mounting surface using the supplied hardware.
1. Position the unit in its proposed mounting location to ensure that it fits properly. With the unit in place, insert an awl or other suitable tool into the mounting screw area of the power supply and scribe the areas that are to be drilled.
 2. Remove the unit from its mounting area and, using a drill bit sized for a #10 sheet metal screw, drill a hole in each of the areas scribed in the previous step.
 3. Return the unit to its mounting location. Using the supplied #10 sheet metal screws, secure it onto its mounting surface.

Wiring...

Input - Extend appropriately sized wire from the flasher Input Terminals towards the vehicle battery. Connect the Positive (+) wire to a 50 Amp fuse and then to the POS (+) battery terminal. Do not install the fuse until all the wiring is complete! Connect the Negative (-) wire to the NEG (-) battery terminal.

Control - The control wires function as follows:

GREEN - Applying the Green wire to ground will place the flasher in Primary Mode operation. In this mode, Outputs A & B will alternate with Outputs C, D & E. **NOTE: Low Power Operation is NOT available in Primary Mode.**

BLUE - Applying the Blue wire to ground will place the flasher in Secondary Mode operation. In this mode, Outputs A & B will alternate with Output D.

VIOLET - Applying the Violet wire to ground will place the flasher in Low Power Mode. In this mode, the intensity of all active lighthoods is significantly reduced. A Single Pole/Single Throw switch should be used to control this function. Removing this wire from ground will restore normal high power operation. **NOTE: Low Power Operation is NOT available in Primary Mode.**

YELLOW - Applying the Yellow wire to ground will disable Output D (Amber). **NOTE: Amber disable is NOT available in Primary Mode.**

WHITE/VIOLET - The White/Violet wire is used for Scan-Lock™ pattern control. A momentary switch (normally open) should be used to control this function. Scan-Lock™ operation is as follows:

TO CYCLE THROUGH ALL PATTERNS: Apply the White/Violet wire to ground for less than 1 second and release to cycle forward. Apply the White/Violet wire to ground for more than 1 second and release to cycle backward.

TO SET A PATTERN AS DEFAULT: When the desired pattern is displayed, allow it to run for more than 5 seconds. The lighting system will now display this pattern when active.

TO RESET TO THE FACTORY DEFAULT PATTERN: With the flasher off, apply the White/Violet wire to ground and turn power back on. When the default pattern is displayed, remove the White/Violet wire from ground and allow the pattern to run for at least 5 seconds.

Output - As shown in the illustrations below, every lighthouse installed belongs to 1 of 5 possible light groups, depending on its mounted location. These are identified as groups A thru E. Connect the positive lead from each lighthouse in group A to flasher output terminal A. Connect the negative leads from these lighthoods to ground.

Follow the same procedure for the remaining groups.

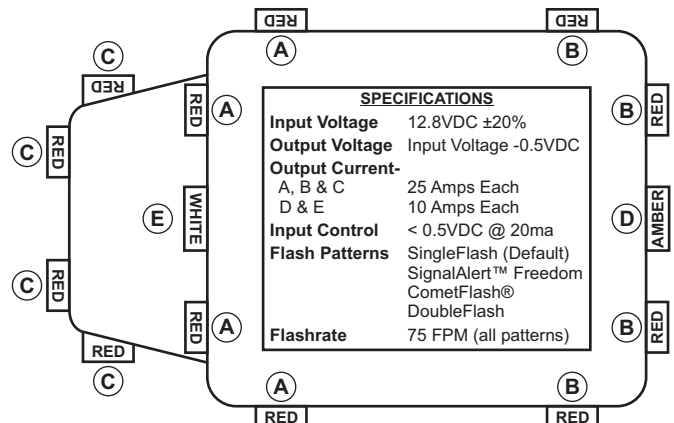
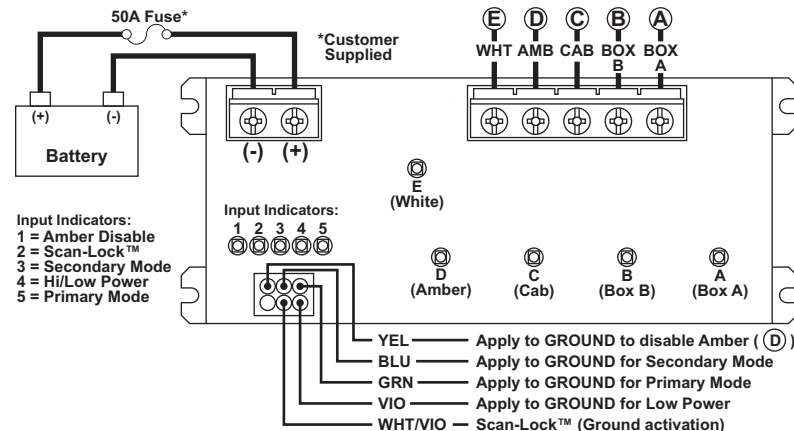

Warnings to Installers

Whelen's emergency vehicle warning devices must be properly mounted and wired in order to be effective and safe. Read and follow all of Whelen's written instructions when installing or using this device. Emergency vehicles are often operated under high speed stressful conditions which must be accounted for when installing all emergency warning devices. Controls should be placed within convenient reach of the operator so that he can operate the system without taking his eyes off the roadway. Emergency warning devices can require high electrical voltages and/or currents. Properly protect and use caution around live electrical connections. Grounding or shorting of electrical connections can cause high current arcing, which can cause personal injury and/or vehicle damage, including fire. Many electronic devices used in emergency vehicles can create or be affected by electromagnetic interference. Therefore, after installation of any electronic device it is necessary to test all electronic equipment simultaneously to insure that they operate free of interference from other components within the vehicle. Never power emergency warning equipment from the same circuit or share the same grounding circuit with radio communication equipment. All devices should be mounted in accordance with the manufacturer's instructions and securely fastened to vehicle elements of sufficient strength to withstand the forces applied to the device. Driver and/or passenger air bags (SRS) will affect the way equipment should be mounted. This device should be mounted by permanent installation and within the zones specified by the vehicle manufacturer, if any. Any device mounted in the deployment area of an air bag will damage or reduce the effectiveness of the air bag and may damage or dislodge the device. Installer must be sure that this device, its mounting hardware and electrical supply wiring does not interfere with the air bag or the SRS wiring or sensors. Mounting the unit inside the vehicle by a method other than permanent installation is not recommended as unit may become dislodged during swerving; sudden braking or collision. Failure to follow instructions can result in personal injury. Whelen assumes no liability for any loss resulting from the use of this warning device. **PROPER INSTALLATION COMBINED WITH OPERATOR TRAINING IN THE PROPER USE OF EMERGENCY WARNING DEVICES IS ESSENTIAL TO INSURE THE SAFETY OF EMERGENCY PERSONNEL AND THE PUBLIC.**

Warnings to Users

Whelen's emergency vehicle warning devices are intended to alert other operators and pedestrians to the presence and operation of emergency vehicles and personnel. However, the use of this or any other Whelen emergency warning device does not guarantee that you will have the right-of-way or that other drivers and pedestrians will properly heed an emergency warning signal. Never assume you have the right-of-way. It is your responsibility to proceed safely before entering an intersection, driving against traffic, responding at a high rate of speed, or walking on or around traffic lanes. Emergency vehicle warning devices should be tested on a daily basis to ensure that they operate properly. When in actual use, the operator must ensure that both visual and audible warnings are not blocked by vehicle components (i.e.: open trunks or compartment doors), people, vehicles, or other obstructions. It is the user's responsibility to understand and obey all laws regarding emergency warning devices. The user should be familiar with all applicable laws and regulations prior to the use of any emergency vehicle warning device. Whelen's audible warning devices are designed to project sound in a forward direction away from the vehicle occupants. However, because sustained periodic exposure to loud sounds can cause hearing loss, all audible warning devices should be installed and operated in accordance with the standards established by the National Fire Protection Association.