

# WHELEN<sup>®</sup>

ENGINEERING COMPANY INC.

Route 145, Winthrop Road,

Chester, Connecticut 06412

Phone: (860) 526-9504

Fax: (860) 526-4078

Internet: [www.whelen.com](http://www.whelen.com)

Sales e-mail: [autosale@whelen.com](mailto:autosale@whelen.com)

Canadian Sales e-mail: [autocan@whelen.com](mailto:autocan@whelen.com)

Customer Service e-mail: [custserv@whelen.com](mailto:custserv@whelen.com)

## Installation Guide: Rear Deck TN™-series Model TLNCSV5\*\* 2005 Crown Victoria

### Safety First

This document provides all the necessary information to allow your Whelen product to be properly and safely installed. Before beginning the installation and/or operation of your new product, the installation technician and operator must read this manual completely. Important information is contained herein that could prevent serious injury or damage.

- **Proper installation of this product requires the installer to have a good understanding of automotive electronics, systems and procedures.**
- **If mounting this product requires drilling holes, the installer MUST be sure that no vehicle components or other vital parts could be damaged by the drilling process. Check both sides of the mounting surface before drilling begins. Also de-burr the holes and remove any metal shards or remnants. Install grommets into all wire passage holes.**
- **If this manual states that this product may be mounted with suction cups, magnets, tape or Velcro™, clean the mounting surface with a 50/50 mix of isopropyl alcohol and water and dry thoroughly.**
- **Do not install this product or route any wires in the deployment area of your air bag. Equipment mounted or located in the air bag deployment area will damage or reduce the effectiveness of the air bag, or become a projectile that could cause serious personal injury or death. Refer to your vehicle owners manual for the air bag deployment area. The User/Installer assumes full responsibility to determine proper mounting location, based on providing ultimate safety to all passengers inside the vehicle.**
- **For this product to operate at optimum efficiency, a good electrical connection to chassis ground must be made. The recommended procedure requires the product ground wire to be connected directly to the NEGATIVE (-) battery post (this does not include products that use cigar power cords).**
- **If this product uses a remote device for activation or control, make sure that this device is located in an area that allows both the vehicle and the device to be operated safely in any driving condition.**
- **Do not attempt to activate or control this device in a hazardous driving situation.**
- **This product contains either strobe light(s), halogen light(s), high-intensity LEDs or a combination of these lights. Do not stare directly into these lights. Momentary blindness and/or eye damage could result.**
- **Use only soap and water to clean the outer lens. Use of other chemicals could result in premature lens cracking (crazing) and discoloration. Lenses in this condition have significantly reduced effectiveness and should be replaced immediately. Inspect and operate this product regularly to confirm its proper operation and mounting condition. Do not use a pressure washer to clean this product.**
- **It is recommended that these instructions be stored in a safe place and referred to when performing maintenance and/or reinstallation of this product.**
- **FAILURE TO FOLLOW THESE SAFETY PRECAUTIONS AND INSTRUCTIONS COULD RESULT IN DAMAGE TO THE PRODUCT OR VEHICLE AND/OR SERIOUS INJURY TO YOU AND YOUR PASSENGERS!**

**For warranty information regarding this product, visit [www.whelen.com/warranty](http://www.whelen.com/warranty)**

## Installation / 2005 Crown Victoria:

- Following the manufacturers instructions, remove the rear seat. Pry the brake light straight up and off of the rear deck as you disconnect the brake light wire.
- Remove the two "christmas tree" fasteners securing the deck and remove the deck.
- The brake light body leaves an indented mark in the rear deck. Using this mark as a guide, position the TN bracket behind the brake light approximately 1/8 of an inch away from this mark. Be sure the bracket is square with the rear window and mark off the location of the 2 mounting holes and the wire access hole onto the deck.

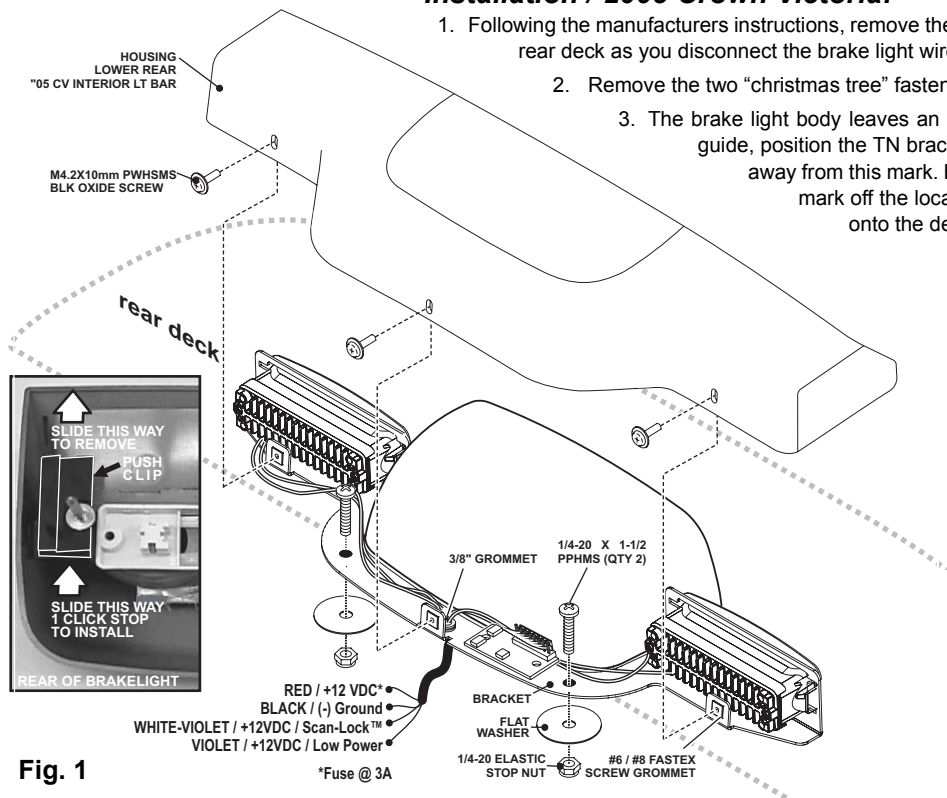

Fig. 1

- Drill the mounting holes and wire access hole. Use a 9/32" bit for the mounting holes and a 1/2" bit for the wire hole. Secure the bracket to the deck using the hardware provided and reinstall the deck onto the vehicle.
- Slide the 2 push clips off of the center brake light then slide them back on until they click once (fig. 1). Reconnect and reinstall the rear brake light.
- Feed the lighthouse wires through the access hole and extend the RED (Positive) wire and the BLACK (Ground) wire to your switched power source. Fuse the RED wire at 3 amps.

**WARNING! All customer supplied wires that connect to the positive terminal of the battery must be sized to supply at least 125% of the maximum operating current and FUSED at the battery to carry that load. DO NOT USE CIRCUIT BREAKERS WITH THIS PRODUCT!**

### Low Power / VIOLET:

The type of switch used is dependant on how the operator wishes the Hi/Lo feature to function:

**Latching Mode:** By applying +12VDC to the VIOLET wire for less than 1 sec., the light is "latched" into low power operation. Turn the unit off and then back on to reset to high power. A momentary switch is preferred for this function.

**Level Mode:** Applying +12 VDC to the VIOLET wire for more than 1 sec. places the lightbar in low power mode until voltage is removed. A toggle switch is preferred for this function.

### Scan-Lock™ / WHITE-VIOLET:

**TO CYCLE FORWARD THROUGH AVAILABLE PATTERNS:** Activate the lighthoods. Apply +12VDC to the Scan-Lock™ wire for less than 1 second and release. This will change the pattern. Repeat this procedure until the desired pattern is displayed. Let this pattern run for at least 5 seconds and it will become the default pattern. Repeat to advance to the next pattern.

**TO RESET TO THE FACTORY DEFAULT PATTERN:** Turn the unit off. While applying +12 volts to the Scan-Lock™ wire turn the unit back on. The lighthoods are now restored to there factory default pattern.

#	PATTERN	OUTLET FUNCTION
1A	SignalAlert™	1 Alternates with 2
1S	SignalAlert™	1 & 2 Simultaneous
1C	SignalAlert™	3 Cycles of 1A & 3 Cycles of 1B
2A	CometFlash®	1 Alternates with 2
2S	CometFlash®	1 & 2 Simultaneous
2C	CometFlash®	3 Cycles of 1A & 3 Cycles of 1B
3A	DoubleFlash	1 Alternates with 2
3S	DoubleFlash	1 & 2 Simultaneous
3C	DoubleFlash	3 Cycles of 1A & 3 Cycles of 1B
4A	SingleFlash	1 Alternates with 2
4S	SingleFlash	1 & 2 Simultaneous
4C	SingleFlash	3 Cycles of 1A & 3 Cycles of 1B
5	Steady Flash	1 & 2 Steady, 3 & 4 SingleFlash (SIM.)
6	Steady	1, 2, 3 & 4 Steady

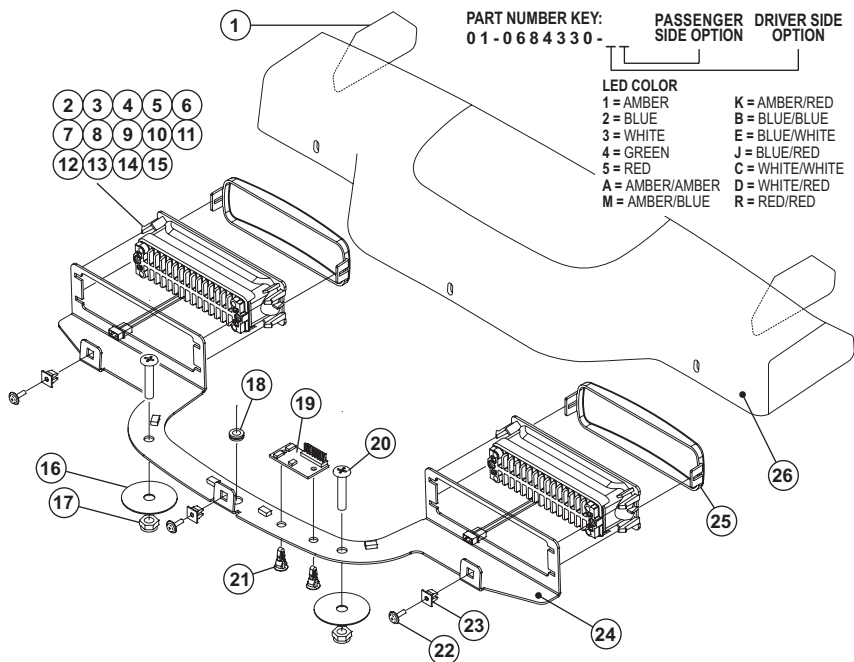

QTY	ITEM	PART NUMBER	DESCRIPTION
*		01-0684330-**	FINAL ASSEMBLY / REAR DECK TN
2	1	68-5943246-01	MIRROR
A/R	2	01-0264260-12	LINEAR 6 LED 500 SERIES (AMBER)
A/R	3	01-0264260-22	LINEAR 6 LED 500 SERIES (BLUE)
A/R	4	01-0264260-32	LINEAR 6 LED 500 SERIES (WHITE)
A/R	5	01-0264260-42	LINEAR 6 LED 500 SERIES (GREEN)
A/R	6	01-0264260-52	LINEAR 6 LED 500 SERIES (RED)
A/R	7	01-0264260-Y2	LINEAR 6 LED 500 SERIES (AMBER/AMBER)
A/R	8	01-0264260-M2	LINEAR 6 LED 500 SERIES (AMBER/BLUE)
A/R	9	01-0264260-K2	LINEAR 6 LED 500 SERIES (AMBER/RED)
A/R	10	01-0264260-B2	LINEAR 6 LED 500 SERIES (BLUE/BLUE)
A/R	11	01-0264260-E2	LINEAR 6 LED 500 SERIES (BLUE/WHITE)
A/R	12	01-0264260-J2	LINEAR 6 LED 500 SERIES (BLUE/RED)
A/R	13	01-0264260-C2	LINEAR 6 LED 500 SERIES (WHITE/WHITE)
A/R	14	01-0264260-D2	LINEAR 6 LED 500 SERIES (WHITE/RED)
A/R	15	01-0264260-R2	LINEAR 6 LED 500 SERIES (RED/RED)
2	16		WASHER / FLAT .280 ID x 1.25 OD .06 THK SS
2	17		NUT - 1/4-20 ELASTIC STOP
1	18	21-11061209-0	3/8" GROMMET
1	19	02-0164325-00	ASSY / FLASHER
2	20		SCREW - 1/4-20 x 5/8" PPHMS
2	21	20-0017569-00	SPACER / MTG.
3	22	15-M23B1C-120	SCREW, M4.2 X 12MM, BLACK OXIDE
3	23	13-062C40-16J	SCREW GROMMET / #6 or #8 FASTEX
1	24	07-284334-000	BRACKET / MTG.
2	25	68-3963604-30	LENS / CLEAR NON OPTIC SNAP-ON
1	26	11-484333-000	HOUSING / LOWER REAR '05" CV