

WHELEN[®]

ENGINEERING COMPANY INC.

Route 145, Winthrop Road,
 Chester, Connecticut 06412
 Phone: (860) 526-9504
 Fax: (860) 526-2009
 Internet: www.whelen.com
 Sales/Service e-mail: aviation@whelen.com

Position/Anti-Collision Light Assembly
Model(s):
7100001, 7100002, 7100003, 7100004
01-0771000-01, 01-0771000-02
01-0771000-03, 01-0771000-04



TSO-C30c
TYPE I, II
APPROVED

TSO-C96a
CLASS III
APPROVED

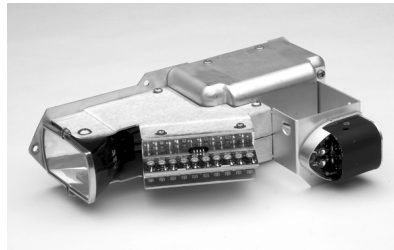

OPERATING INSTRUCTIONS:

LED POSITION LIGHT	28VDC (NOM.) 0.3 AMPS
LED ANTI-COLLISION LIGHT	28VDC (NOM.) 4.0 AMPS @ .25 SEC.
RECOGNITION LIGHT	28VDC (NOM.) 1.25 AMPS

The conditions and tests required for TSO approval of this article are minimum performance standards. It is the responsibility of those installing this article either on or within a specific type or class of aircraft to determine that the aircraft installation conditions are within the TSO standards. TSO articles must have separate approval for installation in aircraft. The article may be installed only if performed under 14 CFR part 43 or the applicable airworthiness requirements.

CONTINUED AIRWORTHINESS: The 71000 series Position/Anti-collision assembly utilizes a Model 71015-series Position Light designed with 6 LED's. If any one LED fails, the unit must be repaired or replaced. The Anti-collision System is designed with four banks of 5 LED's. Should any one of the four banks fail, the unit will automatically shut down and repair or replacement will be necessary. If any one or two single LED's fail, the unit will still meet light output requirements. If three or more LED's fail, the unit must be repaired or replaced.

EQUIPMENT LIMITATIONS: The Class III anti-collision system must produce a minimum of 100 effective candelas in aviation red or white, 360° around the vertical axis, 30° above and below the horizontal plane. Model 71000-series Anti-collision Light Systems will provide 120° of coverage at each wingtip, equal to 240° total coverage. An approved forward position lighting system consists of two lights. Model 71000 has one light located on each wingtip.

INSTALLATION PROCEDURES: The following information is to assist in the installation of a Whelen LED Position/Anti-Collision Light Assembly.

1. Choose the appropriate 71000() Position/Anti-collision light assembly which is most applicable to your aircraft.
2. The installation procedure described in the following text will be confined to a single light installation, but is identical for multiple light installations.
3. Remove old light, locate and save the existing +28VDC lead and (-) ground lead. Clean and prep lead ends as required.
4. Use existing mounting holes and hardware.
5. Connect the +28 VDC and (-) ground leads equipped with an appropriate sized breaker to the LED Light. Both leads must be connected by an approved FAA connection.
6. Install light assembly and insure that the wire leads are clear of any obstructions and ty-wrap as required. Use lock washers and/or thread lock on all threaded fasteners.
7. Check all avionics systems for interference from the installation.
8. A flight check should be performed by a properly certified pilot.
9. Update aircraft records, complete Form 337 and obtain FAA field approval for installation.

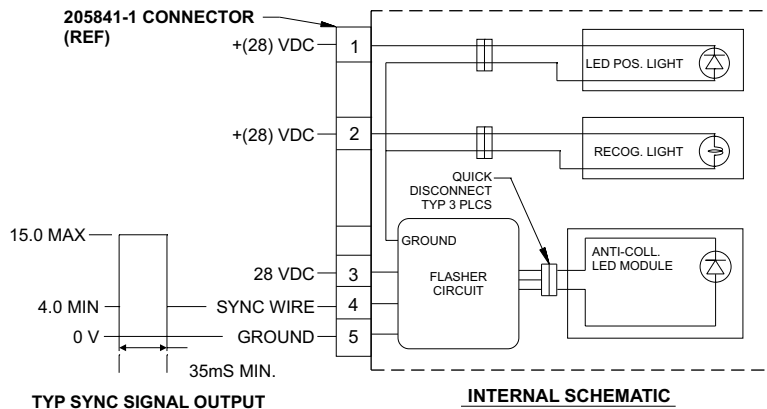

(see page 2 for part numbers and corresponding diagram)

Aviation

QTY	QTY	QTY	QTY	ITEM	PART NUMBER	DESCRIPTION
		*			01-0790300-01	MODEL 7100001 (RED)
		*			01-0790300-02	MODEL 7100002 (GREEN)
	*				01-0790300-03	MODEL 7100003 (RED w/RECOG. LIGHT)
*					01-0790300-04	MODEL 7100004 (GREEN w/RECOG. LIGHT)
-	1	-	1	1	01-0771015-02	LED FWD POS LIGHT ASS'Y (RED) 28V
1	-	1	-	2	01-0771015-01	LED FWD POS LIGHT ASS'Y (GREEN) 28V
-	1	-	1	3	07-790064-001	MOUNTING BRACKET (LEFT) IRIDITED
1	-	1	-	4	07-790064-001	MOUNTING BRACKET (RIGHT) IRIDITED
2	2	2	2	5	14-0050508-28	SCREW, #6-32 x 3/8" PFHMS MS51959-28
1	1	1	1	6	14-0050508-30	SCREW, #6-32 x 1/2" PFHMS MS51959-30
9	9	9	9	7	14-0050504-43	SCREW, #8-32 x 3/8" PFHMS MS51957-43
1	1	1	1	8	01-0790309-00	ASS'Y CURRENT SOURCE FLASHER PWR
1	1	1	1	9	07-790297-002	SIDE PANEL (LEFT) IRIDITED
1	1	1	1	10	07-790286-002	SIDE PANEL (RIGHT) IRIDITED
2	2	2	2	11	13-0050562-30	NUT, #10-32 SELF-LOCKING HEX MS21044C3
-	-	1	1	12	01-0770453-00	ASS'Y, A775-EXP RECOGNITION LIGHT (28V)
-	-	2	2	13	14-102316-060	SCREW, #10-32 x 3/8" PHTRUSS HD SS
1	1	1	1	14	01-0271020-00	SUB-ASS'Y, LED ANTI-COLLISION HEAT SINK
4	4	4	4	15	14-0050503-28	SCREW, #6-32 x 3/8" PPHMS MS51957-28
A/R	A/R	A/R	A/R	16	66-0717330-00	THREADLOCKER, 222MS SERIES

