

WHELEN[®]

ENGINEERING COMPANY INC.

Route 145, Winthrop Road,
Chester, Connecticut 06412
Phone: (860) 526-9504
Fax: (860) 526-2009
Internet: www.whelen.com
Sales/Service e-mail: aviation@whelen.com

Installation Guide: Model 70899() Strobe Power Supply Assembly TSO-C96a Approved.

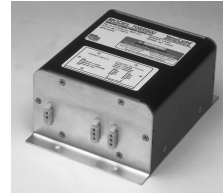

Specifications

Model Number - 7089900
Part Number - 01-0770899-00
Current Draw - 2.4 Amps @ 28 Volts D.C.
Weight - 1.8 lbs.
Length - 5.5"
Height - 3.0"
Width - 5.0"

The conditions and tests required for TSO approval of this article are minimum performance standards. It is the responsibility of those installing this article either on or within a specific type or class of aircraft to determine that the aircraft installation conditions are within the TSO standards. TSO articles must have separate approval for installation in aircraft. The article may be installed only if performed under 14 CFR part 43 or the applicable airworthiness requirements.

OPERATION: This power supply will operate up to 2 strobe light head assemblies. Total power to each output is 36 joules. Output 1 alternates with output 2. The typical configuration is to connect output 1 to one wingtip strobe light assembly and output 2 to the other wingtip strobe light assembly.

CONTINUED AIRWORTHINESS: The power supply output should be checked on a regular basis for flash rate. The flash rate may be checked by indirect observation of the strobe lighthouse. Do not look directly at the strobe light. If the strobe does not appear to be functioning correctly, try to determine if the problem is with the power supply or the strobe lighthouse. This can be accomplished by replacing the strobe tube or lighthouse assembly with a good operating unit or with the use of a Whelen Strobe Check unit.

Periodically check the power supply connections and wiring. Also, check and tighten or clean the Ground wire connection at the power supply case.

EQUIPMENT LIMITATIONS: An approved Anti-Collision System consists of Power Supply 70899() connected to two Whelen Strobe Light Assemblies, model A650 Series, A600 Series or A625 Series.

INSTALLATION PROCEDURES:

Location

1. Consider areas or locations designated by the aircraft manufacturer. Do not mount the strobe power supply any closer than 3 feet from the ADF loop.
2. For alternate locations, consider areas such as the cabin baggage compartment, the floor under the seat, non-structural bulkheads, firewalls etc.
3. If necessary, fabricate support brackets or shelves, and attach them to the aircraft structure to provide a mounting surface that will withstand the inertia forces stipulated in chapters 1 & 3 of AC 43.13-2A
4. An "IA" or other representative of the FAA must approve documentation of structural integrity of the fabricated installation.
5. Specifically call out the location of the strobe light power supply on FAA form 337.

Wiring

WARNING: STROBE LIGHT POWER SUPPLIES ARE POLARITY SENSITIVE. REVERSING THE INPUT POLARITY WILL CAUSE SEVERE DAMAGE TO THE POWER SUPPLY.

Steps below: "Ref. AC 43.13-1B, Chapter 11, Sections 1,2,3, & 7".

1. Choosing wire size of A+ input lead, refer to Paragraph 444 "Electric Wire Chart" Figure 11.7 and 11.7A, with reference to Strobe Light Model Current requirement chart on page 6 and 11, and "Wire and Circuit Protection Chart" Figure 11.1.
2. Shielded wire is not generally necessary, but has proven effective in reducing the possibility of radio interference.
3. The power supply shall acquire its power from a low impedance source such as the alternator or generator end of the electrical buss as close to the battery as possible.
4. For penetrating pressure hull, refer to the aircraft service manual.
5. Check all avionics systems for interference.

Fig. 1

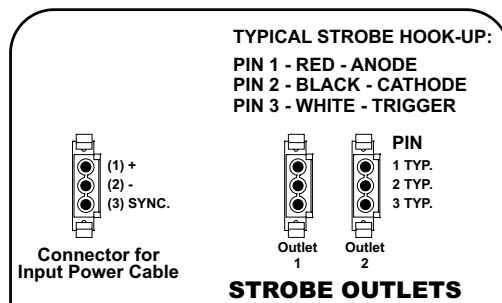

Interconnecting Cable

1. The Whelen interconnecting cable shall be secured in place with approved aviation techniques.
2. The cable shall not parallel ADF, Gyro or Flux Gate compass leads closer than 12 inches.
3. CABLE COLORING CODING (see Figure 3):
 - PIN 1 - RED** (Anode)
 - PIN 2 - BLACK** (Cathode, flash tube ground)
 - PIN 3 - WHITE** (Trigger)
 - SHIELD** - Ground at power supply end only

CAUTION: When pins 1 & 2 or pins 2 & 3 are reversed, the system will appear to operate normally, however this condition will cause premature flash tube failure.

IMPORTANT NOTE:

Your new strobe power supply has an additional circuit built-in to prevent self-ionization (steady glowing) of the strobe tubes. In some cases, when replacing older power supplies, the bare shield wire in the existing harness is pinned together at each end with the black wire. The following modification must be made to ensure proper operation.

1. At the strobe tube end of the cable, cut the shield wire and tape it off (DO NOT CUT THE BLACK WIRE).
2. At the power supply end of the cable, cut the shield wire and connect it to a good ground (DO NOT CUT THE BLACK WIRE).
3. This must be done for each strobe light connection (see Fig. 2).

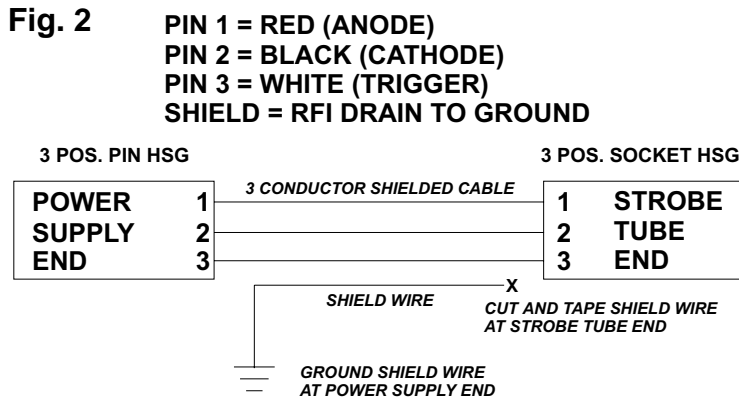

INTERMIXING STROBE LIGHT SYSTEM EQUIPMENT

OBSERVE COLOR AND PIN NUMBERS. CABLES CONNECTING REMOTE POWER SUPPLY TYPE STROBE LIGHTS MUST BE CONNECTED CORRECTLY!

Whelen Engineering and Aero-flash wiring between light assemblies and remote power supplies are identical as pictured below.

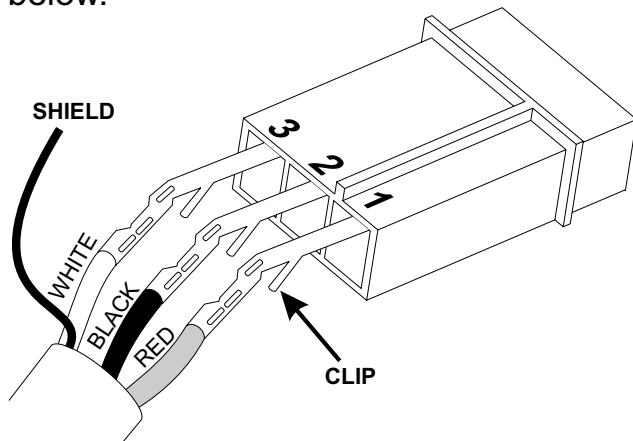

Grimes and SDI (Hoskins) wiring between light assemblies and remote power supplies are identical as pictured below.

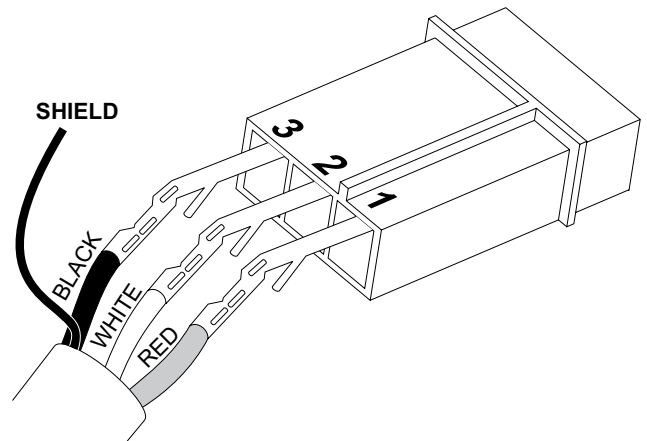

Both Grimes and SDI sometimes use MS (Cannon Type) Connectors:
A = RED (Anode), **B = WHITE** (Trigger),
C = BLACK (Ground)