

# WHELEN<sup>®</sup>

ENGINEERING COMPANY INC.

Route 145, Winthrop Road,  
Chester, Connecticut 06412

Phone: (860) 526-9504

Fax: (860) 526-4078

Internet: [www.whelen.com](http://www.whelen.com)

Sales e-mail: [autosale@whelen.com](mailto:autosale@whelen.com)

Canadian Sales e-mail: [autocan@whelen.com](mailto:autocan@whelen.com)

Customer Service e-mail: [custserv@whelen.com](mailto:custserv@whelen.com)

## Installation Guide UPS64HA Strobe Power Supply

### Safety First

This document provides all the necessary information to allow your Whelen product to be properly and safely installed. Before beginning the installation and/or operation of your new product, the installation technician and operator must read this manual completely. Important information is contained herein that could prevent serious injury or damage.

- **Proper installation of this product requires the installer to have a good understanding of automotive electronics, systems and procedures.**
- **If mounting this product requires drilling holes, the installer MUST be sure that no vehicle components or other vital parts could be damaged by the drilling process. Check both sides of the mounting surface before drilling begins. Also de-burr any holes and remove any metal shards or remnants. Install grommets into all wire passage holes.**
- **If this manual states that this product may be mounted with suction cups, magnets, tape or Velcro™, clean the mounting surface with a 50/50 mix of isopropyl alcohol and water and dry thoroughly.**
- **Do not install this product or route any wires in the deployment area of your air bag. Equipment mounted or located in the air bag deployment area will damage or reduce the effectiveness of the air bag, or become a projectile that could cause serious personal injury or death. Refer to your vehicle owners manual for the air bag deployment area. The User/Installer assumes full responsibility to determine proper mounting location, based on providing ultimate safety to all passengers inside the vehicle.**
- **For this product to operate at optimum efficiency, a good electrical connection to chassis ground must be made. The recommended procedure requires the product ground wire to be connected directly to the NEGATIVE (-) battery post.**
- **If this product uses a remote device to activate or control this product, make sure that this control is located in an area that allows both the vehicle and the control to be operated safely in any driving condition.**
- **Do not attempt to activate or control this device in a hazardous driving situation.**
- **It is recommended that these instructions be stored in a safe place and referred to when performing maintenance and/or reinstallation of this product.**
- **FAILURE TO FOLLOW THESE SAFETY PRECAUTIONS AND INSTRUCTIONS COULD RESULT IN DAMAGE TO THE PRODUCT OR VEHICLE AND/OR SERIOUS INJURY TO YOU AND YOUR PASSENGERS!**

**For warranty information regarding this product, visit [www.whelen.com/warranty](http://www.whelen.com/warranty)**

**Selecting a mounting location...**

The most common choice for a mounting area would be a trunk or similar compartment. However, due to the wide variety of vehicles onto which the UPS64HA could be installed, this is not always possible. The following guidelines will help determine an acceptable alternative:

- The unit should be mounted on a metal surface to aid heat dissipation. Be sure that this surface is not one that either generates or is exposed to excessive heat during normal operation of the vehicle.
- Do not select a location where the unit will be exposed to potential damage from any unsecured or loose equipment in the vehicle.
- Be sure the area selected will not allow the unit to be exposed to water!
- When routing wires, it is important to choose a path that will keep these wires away from excessive heat and from any vehicle equipment that could compromise the integrity of the wires (ex. trunk lids, door jams, etc.).
- When the best mounting location has been determined, securely fasten the unit to it's mounting surface using the supplied hardware.

**WARNING: The Strobe Light Power Supply is a high voltage device. Do not touch or remove tube assembly in strobe light head assemblies while in operation. Wait 10 minutes after disconnecting the unit from its power source before starting work or troubleshooting on power supply or system.**

1. Position the unit in its proposed mounting location to ensure that it fits properly. With the unit in place, insert an awl or other suitable tool into the mounting screw area of the power supply and scribe the areas that are to be drilled.
2. Remove the unit from its mounting area and, using a drill bit sized for a #10 sheet metal screw, drill a hole in each of the areas scribed in the previous step.
3. Return the unit to its mounting location. Using the supplied #10 sheet metal screws, secure it onto its mounting surface.

**Wiring ...**

1. Locate the 3 position **Power Connector** included with your power supply and plug it into the port indicated in Fig. 1. Extend the BLACK and RED wires towards the battery.

**WARNING! All customer supplied wires that connect to the positive terminal of the battery must be sized to supply at least 125% of the maximum operating current and FUSED at the battery to carry that load. DO NOT USE CIRCUIT BREAKERS WITH THIS PRODUCT!**

2. Connect the RED wire to a fuse block (customer supplied) and then to the POSITIVE terminal on the battery.

**NOTE! Although a fuse (customer supplied) is required to be used in the fuse block, do not install the fuse until all of the wire connections are completed.**

3. Connect the BLACK wire to the factory chassis ground adjacent to the battery (see "Turn Signal Override" for the VIO wire function).
4. Refer to Fig. 2 for wiring information for the **Control Connector** and for the **Scan-Lock™ Connector**.

**Turn Signal Override...**

This feature will automatically turn off the UPS64HA whenever the vehicle's turn signals are in use.

1. Connect the GREY wire (from the Scan-Lock connector) to the positive (+) wire of the Left turn signal.
2. Connect the VIO wire (from the Power connector) to the positive (+) wire of the Right turn signal.

**Scan-Lock™ Operation...**

**To cycle through all patterns:** Apply the WHT/VIO wire to Ground for less than 1 second and release to cycle forward.

Apply to Ground for more than 1 second and release to cycle backward.

**To set a pattern as Default:** When the desired pattern is displayed, allow it to run for more than 5 seconds. The lighthead will now display this pattern when active.

**To reset to the Factory Default pattern:** Turn off power. While applying the WHT/VIO wire to Ground, turn power back on.

**Available Scan-Lock™ Patterns (in order) -**

- |                 |                    |
|-----------------|--------------------|
| 1) CometFlash®  | 6) ModuFlash™      |
| 2) TripleFlash  | 7) MicroBurst II™  |
| 3) DoubleFlash  | 8) MicroBurst III™ |
| 4) RapidRate™   | 9) LongBurst™      |
| 5) ActionFlash™ | 10) ActionScan™    |

**IMPORTANT! Before returning the vehicle to active service, visually confirm the proper operation of the flasher system and all vehicle components/equipment.**

**Fig. 1**

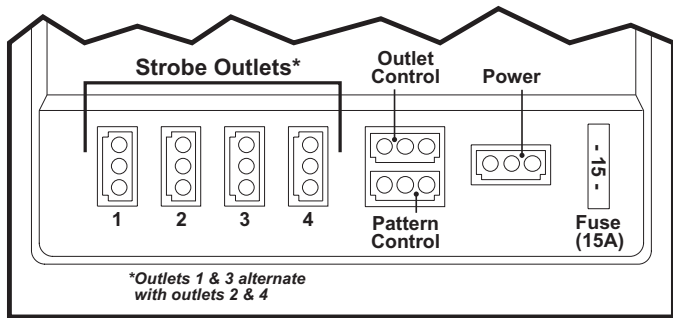

**Fig. 2**

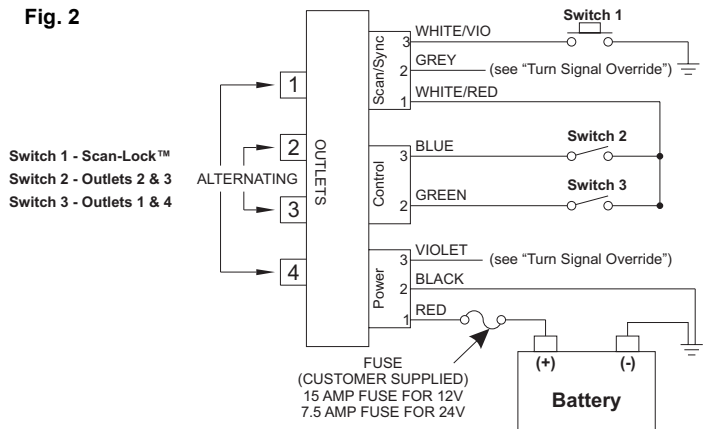

**UPS64HA SPECIFICATIONS:**

<b>INPUT VOLTAGE</b>	-	<b>13.5 VDC (26.5 VDC) ± 20%</b>
<b>INPUT CURRENT @ 4 LAMPS</b>	-	<b>7 AMPS (4AMPS)</b>
<b>INPUT CURRENT @ 2 LAMPS</b>	-	<b>4 AMPS (2.5 AMPS)</b>
<b>OUTPUT POWER @ 4 LAMPS</b>	-	<b>75 Watts</b>
<b>OUTPUT POWER @ 2 LAMPS</b>	-	<b>40 Watts</b>
<b>V Ctrl</b>	-	<b>13.5 VDC (26.5 VDC) ± 20%</b>
<b>I Ctrl</b>	-	<b>100 ma (MAX)</b>
<b>V Output Ctrl</b>	-	<b>13.5 VDC (26.5 VDC) ± 20%</b>
<b>I Output Ctrl</b>	-	<b>20 ma (MAX)</b>
<b>V Pattern Ctrl</b>	-	<b>13.5 VDC (26.5 VDC) ± 20%</b>
<b>I Pattern Ctrl</b>	-	<b>5 (MAX)</b>