

WHELEN[®]

ENGINEERING COMPANY INC.

51 Winthrop Road
Chester, Connecticut 06412-0684
Phone: (860) 526-9504
Fax: (860) 526-4078
Internet: www.whelen.com
Sales e-mail: autosale@whelen.com
Canadian Sales e-mail: autocan@whelen.com
Customer Service e-mail: custserv@whelen.com

Installation Guide: Crown Victoria Headlight Flasher (Positive Switching) For Canadian Use

Safety First

This document provides all the necessary information to allow your Whelen product to be properly and safely installed. Before beginning the installation and/or operation of your new product, the installation technician and operator must read this manual completely. Important information is contained herein that could prevent serious injury or damage.

- **Proper installation of this product requires the installer to have a good understanding of automotive electronics, systems and procedures.**
- **If mounting this product requires drilling holes, the installer MUST be sure that no vehicle components or other vital parts could be damaged by the drilling process. Check both sides of the mounting surface before drilling begins. Also de-burr any holes and remove any metal shards or remnants. Install grommets into all wire passage holes.**
- **If this manual states that this product may be mounted with suction cups, magnets, tape or Velcro®, clean the mounting surface with a 50/50 mix of isopropyl alcohol and water and dry thoroughly.**
- **Do not install this product or route any wires in the deployment area of your air bag. Equipment mounted or located in the air bag deployment area will damage or reduce the effectiveness of the air bag, or become a projectile that could cause serious personal injury or death. Refer to your vehicle owner's manual for the air bag deployment area. The User/Installer assumes full responsibility to determine proper mounting location, based on providing ultimate safety to all passengers inside the vehicle.**
- **For this product to operate at optimum efficiency, a good electrical connection to chassis ground must be made. The recommended procedure requires the product ground wire to be connected directly to the NEGATIVE (-) battery post.**
- **If this product uses a remote device to activate or control this product, make sure that this control is located in an area that allows both the vehicle and the control to be operated safely in any driving condition.**
- **Do not attempt to activate or control this device in a hazardous driving situation.**
- **It is recommended that these instructions be stored in a safe place and referred to when performing maintenance and/or reinstallation of this product.**
- **FAILURE TO FOLLOW THESE SAFETY PRECAUTIONS AND INSTRUCTIONS COULD RESULT IN DAMAGE TO THE PRODUCT OR VEHICLE AND/OR SERIOUS INJURY TO YOU AND YOUR PASSENGERS!**

For warranty information regarding this product, visit www.whelen.com/warranty

IMPORTANT NOTES!

- The use of a flashing headlight system may be regulated by state, county, or municipal authorities. It is the responsibility of the end user to comply with these regulations.
- Before attempting the installation of this headlight flasher, thoroughly read and understand instructions and steps shown below!
- Disconnect the battery from the electrical system before attempting any part of this installation!
- All customer supplied wires that connect to the positive terminal of the battery must be sized to supply at least 125% of the maximum operating current and FUSED at the battery to carry the load. **DO NOT USE CIRCUIT BREAKERS WITH THIS PRODUCT!**
- It is the responsibility of the installer to make sure that the high beam and low beam filaments of a dual filament bulb never come on together. The excessive heat generated by this condition will melt the headlight assembly. The brown disable wire may have to be connected to the parking lights or the low beams to override the flasher and prevent both filaments from coming on simultaneously.

WIRING DIAGRAM

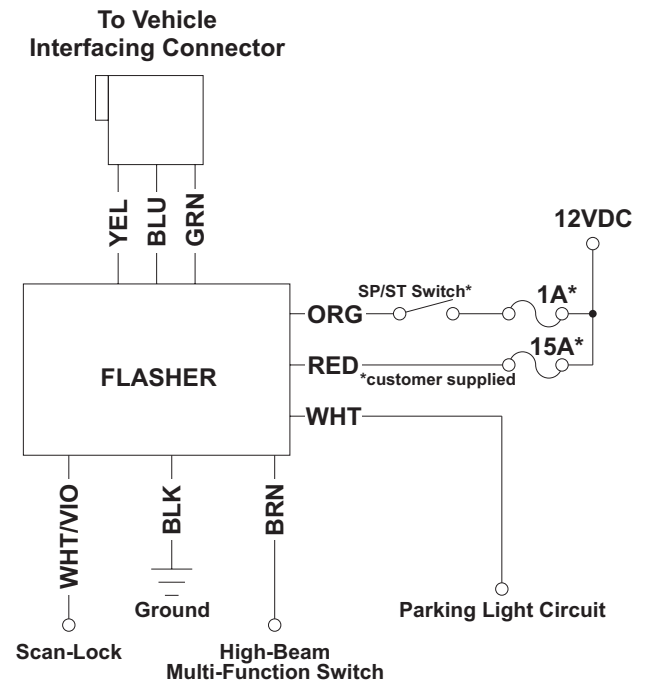

Installation

1. The flasher should be mounted in the engine compartment within reach of the Interface Connector for the vehicle headlight circuit (located near the vehicle horns). Do not mount the unit directly on the engine or close to the exhaust system.
2. Connect the flasher connector into the vehicle interface connector. Make sure that these connectors are fully engaged.
3. Connect the remaining wires to the vehicle as outlined here.

WHITE/VIOLET - See Scan-Lock™ section below.

BLACK - Connect to the vehicle's chassis ground.

BROWN - Connect this wire to the LT GRN/BLK wire between High-Beam Multi-Function Switch connector C202C-Pin10, and connector C2145D-Pin 26 of the Lighting Control Module.

ORANGE - Connect to a +12VDC powered SP/ST switch (200 mA MIN./customer supplied) fused @ 1amp.

RED - Connect this wire to the POS (+) battery terminal and fuse @ 15 amps.

WHITE - Connect this wire to the Parking Light Circuit.

NOTE: Both the WHITE and BROWN wires must be wired as outlined here in order for the flasher to operate.

4. Test the flasher for proper operation.

Scan-Lock™ Flash Pattern Selection

There are 7 available flash patterns for this flasher. These patterns are selected by momentarily applying +12VDC to the WHT/VIO wire. Tape any uninsulated wire when not in use. Flash pattern control is as follows:

TO CYCLE THROUGH ALL FLASH PATTERNS: Apply +12VDC for less than 1 second and release to cycle forward to the next pattern. Apply +12VDC for more than 1 second and release to cycle back to the previous pattern.

TO SET A FLASH PATTERN AS A DEFAULT: When the desired flash pattern is displayed, allow it to run for at least 5 seconds. That pattern will now be displayed when the flasher is activated.

Flash Patterns: 1 - ModuFlash™ (default flash pattern) > 2 - SingleFlash 280 (Alternating) > 3 - DoubleFlash 140 / Simultaneous SingleFlash 140 > 4 - DoubleFlash 140 / SingleFlash 280 > 5 - SingleFlash 140 / Simultaneous DoubleFlash 75 > 6 - SingleFlash 90 (Alternating) > 7 - SingleFlash 140 (Alternating)

IMPORTANT! Before returning this vehicle to active service, visually confirm the proper operation of this product, as well as all vehicle components/equipment.