

WHELEN[®]

ENGINEERING COMPANY INC.

Route 145, Winthrop Road,
Chester, Connecticut 06412
Phone: (860) 526-9504
Fax: (860) 526-2009
Internet: www.whelen.com
Sales/Service e-mail: aviation@whelen.com

Installation Guide: Model 71050()-Series Models: 7105000, 7105001, 7105010, 7105011

P/N: 01-0771050-00, 01-0771050-01,
01-0771050-10, 01-0771050-11
LED Ground Recognition Light Assembly



OPERATING INSTRUCTIONS:

Operational Voltage: 14 / 28 VDC
Average Input Current: 0.2 / 0.27 Amps
Peak Input Current: 1.2 / 1.5 Amps

INSTALLATION PROCEDURES:

The following information is to assist in the installation of a Whelen LED Ground Recognition Light Assembly.

1. Choose the appropriate 71050() replacement light assembly which is most applicable to your aircraft.
2. The installation procedure described in the following text will be confined to a single, top mount light installation.
3. Remove the old light, locate and save the existing (+)VDC lead and (-) ground lead. Clean and prep lead ends as required.
4. Use existing mounting holes and hardware.
5. Connect the (+)VDC and (-) ground leads equipped with an appropriate sized breaker to the LED Light. Both leads must be connected by an approved FAA connection.
6. Install light assembly and insure that the wire leads are clear of any obstructions and ty-wrap as required. Use lock washers and/or thread lock on all threaded fasteners.
7. Check all avionics systems for interference from the installation.
8. A flight check should be performed by a properly certified pilot.
9. Update aircraft records, complete Form 337 and obtain FAA field approval for installation.

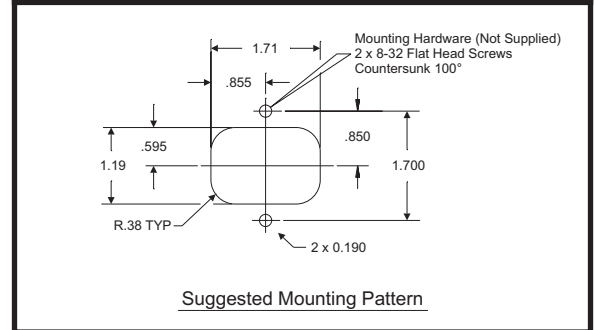
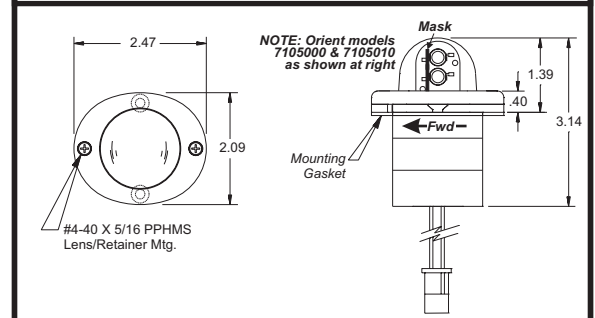
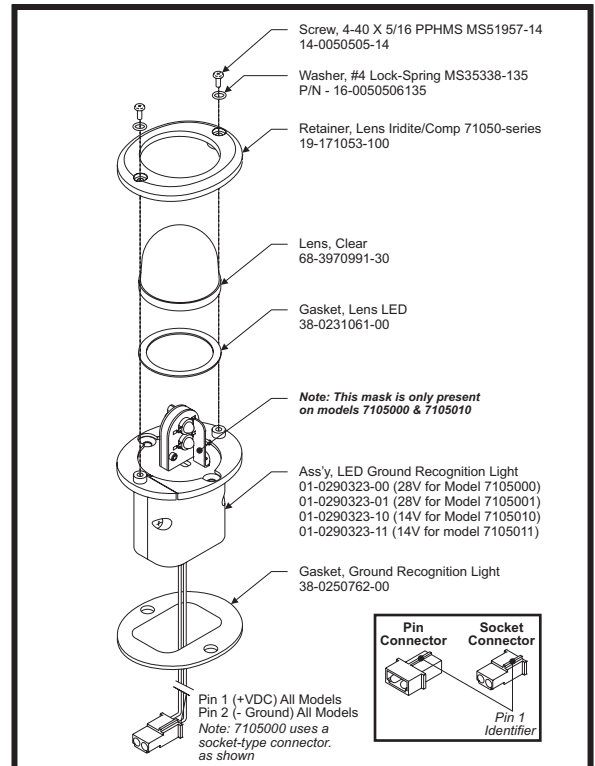

Aviation