

WHELEN[®]

ENGINEERING COMPANY INC.

51 Winthrop Road
 Chester, Connecticut 06412-0684
 Phone: (860) 526-9504
 Fax: (860) 525-4078
 Internet: www.whelen.com
 Sales e-mail: autosale@whelen.com
 Canadian Sales e-mail: autocan@whelen.com
 Customer Service e-mail: custserv@whelen.com

Installation Guide: Control Point Module for WeCan[®] Lightbars

Overview -

The Control Point Module serves as the 'brains' of the Whelen WC Series lightbar. The module is programmed with the WeCan™ Programming Software via the USB port and in turn, provides the necessary signals that allow the lightbar to function in the desired manner.

As represented in the WeCan™ Programming software, each of the 18 inputs may be programmed to activate any number or combination of the installed lightbar components. This is accomplished by applying +12VDC to an input. Refer to the sample wiring diagrams shown on pgs. 2 through 4, or the installation guide included with your switches for detailed wiring information.

Note - The pattern override feature will override all active LED lightheads with the pattern override flash pattern.

Programming Procedure -

IMPORTANT - It is not necessary to program this device unless changes to the default configuration (for example pattern or switch control changes) are desired.

1. Connect a USB cable from the host PC to the module's USB port.
2. Start the WeCan software on the host PC and open the configuration to be programmed.
3. Click on the "WeCan" button on the menu bar. Select "Control Point" then "Program" from the fly-out.
4. A window will open to confirm that you are about to program a Control Point Module. Confirm that the USB cable is connected to both the module and the PC and then press "OK" to continue. The software will display a window when the programming procedure has been successfully completed.
5. Confirm proper operation of the module.

DEFAULT CONFIGURATION (12V Inputs)

POS	COLOR	FUNCTION
1	GREEN	FRONT PATTERN 1
2	GRN/WHT	FRONT PATTERN 2
3	GRN/BLK	FRONT PATTERN 3
4	WHT/RED	FRONT PATTERN 4
5	WHITE	DRIVER ALLEY
6	YELLOW	PASSENGER ALLEY
7	WHT/VIO	AUX
8	WHT/GRN*	RIGHT TRAFFIC ADVISOR™
9	WHT/ORG	CRUISE LIGHTS
10	BLUE	REAR PATTERN 1
11	BLU/WHT	REAR PATTERN 2
12	BLU/BLK	REAR PATTERN 3
13	WHT/BRN	REAR PATTERN 4
14	WHT/BLK	TAKE-DOWNS
15	WHT/BLU	FLASHING TAKE-DOWN / ALLEY
16	RED/WHT	STEADY OVERRIDE
17	WHT/YEL*	LEFT TRAFFIC ADVISOR
18	VIOLET	LOW POWER

*NOTE: Apply +12VDC to the WHT/GRN and WHT/YEL wires simultaneously for split Traffic Advisor.

LIGHTBAR CABLE CONNECTOR

POS	COLOR	FUNCTION
1	RED ¹	+12VDC
2	None	
3	BLACK	GROUND
4	GREEN ²	COMM. A
5	BLK/WHT ²	SHIELD
6	GREY ²	COMM. B

¹ Connect to an ignition controlled circuit that can accommodate an additional 250mA load.

² from lightbar

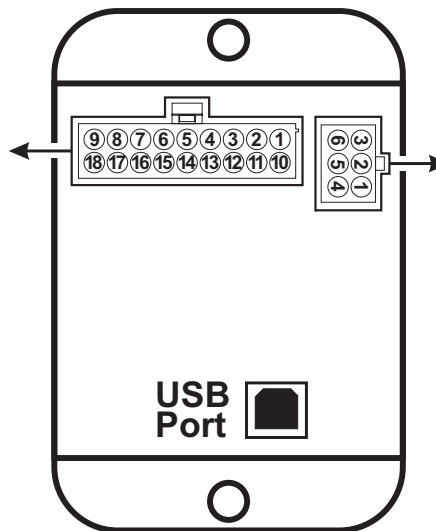

For warranty information regarding this product, visit www.whelen.com/warranty

Example #1: Typical CenCom™ layout. Consult your CenCom manual before making any changes to this circuit.

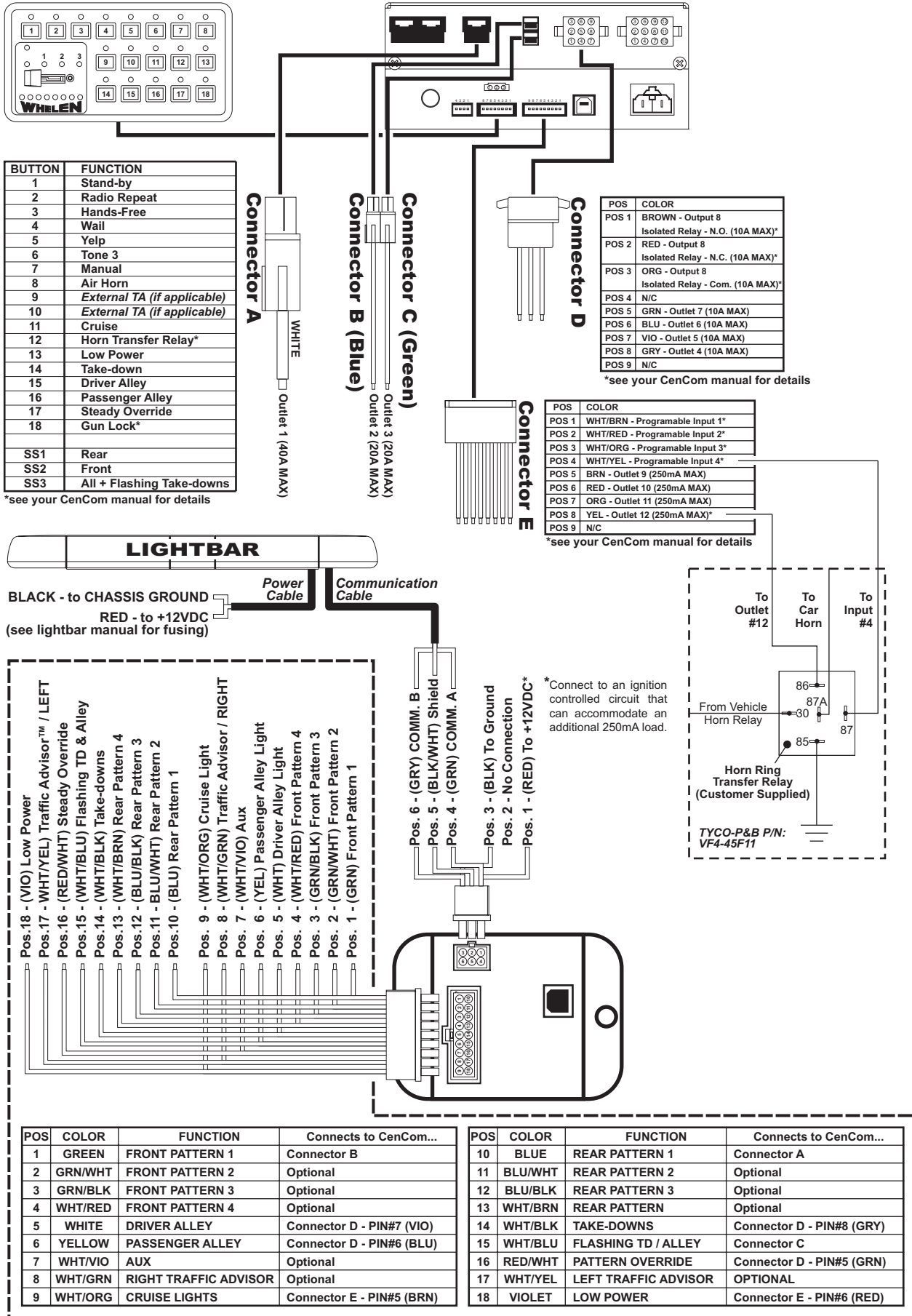

BUTTON	FUNCTION
1	Stand-by
2	Radio Repeat
3	Hands-Free
4	Wail
5	Yelp
6	Tone 3
7	Manual
8	Air Horn
9	External TA (if applicable)
10	External TA (if applicable)
11	Cruise
12	Horn Transfer Relay*
13	Low Power
14	Take-down
15	Driver Alley
16	Passenger Alley
17	Steady Override
18	Gun Lock*
SS1	Rear
SS2	Front
SS3	All + Flashing Take-downs

*see your CenCom manual for details

POS	COLOR
POS 1	BROWN - Output 8 Isolated Relay - N.O. (10A MAX)*
POS 2	RED - Output 8 Isolated Relay - N.C. (10A MAX)*
POS 3	ORG - Output 8 Isolated Relay - Com. (10A MAX)*
POS 4	N/C
POS 5	GRN - Outlet 7 (10A MAX)
POS 6	BLU - Outlet 6 (10A MAX)
POS 7	VIO - Outlet 5 (10A MAX)
POS 8	GRY - Outlet 4 (10A MAX)
POS 9	N/C

*see your CenCom manual for details

POS	COLOR
POS 1	WHT/BRN - Programmable Input 1*
POS 2	WHT/RED - Programmable Input 2*
POS 3	WHT/ORG - Programmable Input 3*
POS 4	WHT/YEL - Programmable Input 4*
POS 5	BRN - Outlet 9 (250mA MAX)
POS 6	RED - Outlet 10 (250mA MAX)
POS 7	ORG - Outlet 11 (250mA MAX)
POS 8	YEL - Outlet 12 (250mA MAX)*
POS 9	N/C

*see your CenCom manual for details

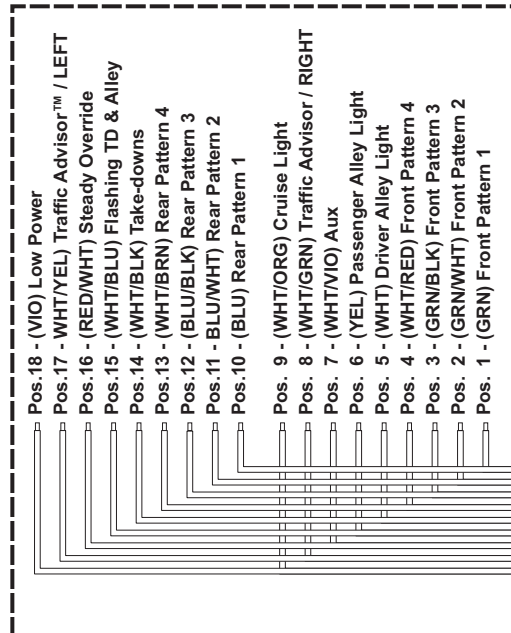
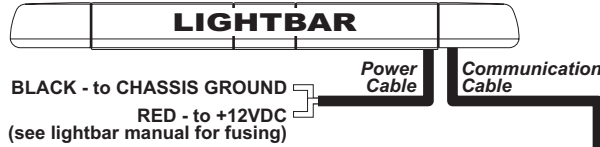

*Connect to an ignition controlled circuit that can accommodate an additional 250mA load.

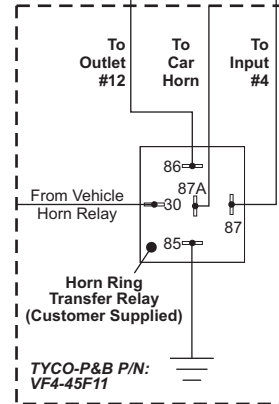

POS	COLOR	FUNCTION	Connects to CenCom...
1	GREEN	FRONT PATTERN 1	Connector B
2	GRN/WHT	FRONT PATTERN 2	Optional
3	GRN/BLK	FRONT PATTERN 3	Optional
4	WHT/RED	FRONT PATTERN 4	Optional
5	WHITE	DRIVER ALLEY	Connector D - PIN#7 (VIO)
6	YELLOW	PASSENGER ALLEY	Connector D - PIN#6 (BLU)
7	WHT/VIO	AUX	Optional
8	WHT/GRN	RIGHT TRAFFIC ADVISOR	Optional
9	WHT/ORG	CRUISE LIGHTS	Connector E - PIN#5 (BRN)

POS	COLOR	FUNCTION	Connects to CenCom...
10	BLUE	REAR PATTERN 1	Connector A
11	BLU/WHT	REAR PATTERN 2	Optional
12	BLU/BLK	REAR PATTERN 3	Optional
13	WHT/BRN	REAR PATTERN	Optional
14	WHT/BLK	TAKE-DOWNS	Connector D - PIN#8 (GRY)
15	WHT/BLU	FLASHING TD / ALLEY	Connector C
16	RED/WHT	PATTERN OVERRIDE	Connector D - PIN#5 (GRN)
17	WHT/YEL	LEFT TRAFFIC ADVISOR	OPTIONAL
18	VIOLET	LOW POWER	Connector E - PIN#6 (RED)

Example #2: Integrating a WeCan® Control Point Module into a 295SLS*6 System.

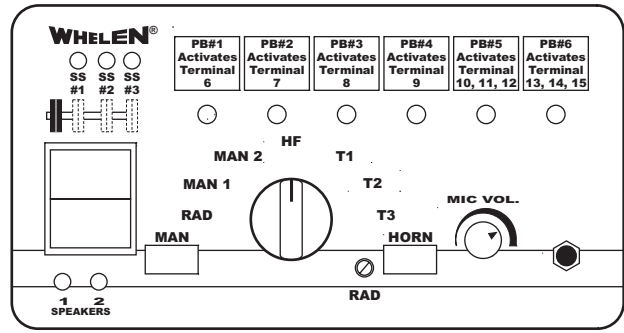
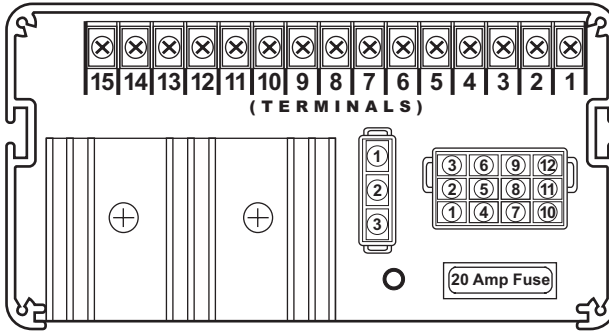

TERMINAL	FUNCTION
1	Slide Switch #1
2	Slide Switch #2
3	
4	Slide Switch #3
5	
6	Push Button #1
7	Push Button #2
8	Push Button #3
9	Push Button #4
10	
11	Push Button #5
12	
13	
14	Push Button #6
15	

BUTTON	FUNCTION
PB1	Take-downs
PB2	Driver Alley Light
PB3	Passenger Alley Light
PB4	Traffic Advisor™ Left
PB5	Traffic Advisor Right
PB6	Low Power
SS1	Rear
SS2	Front + Rear
SS3	Front + Rear + Flashing Take-Downs

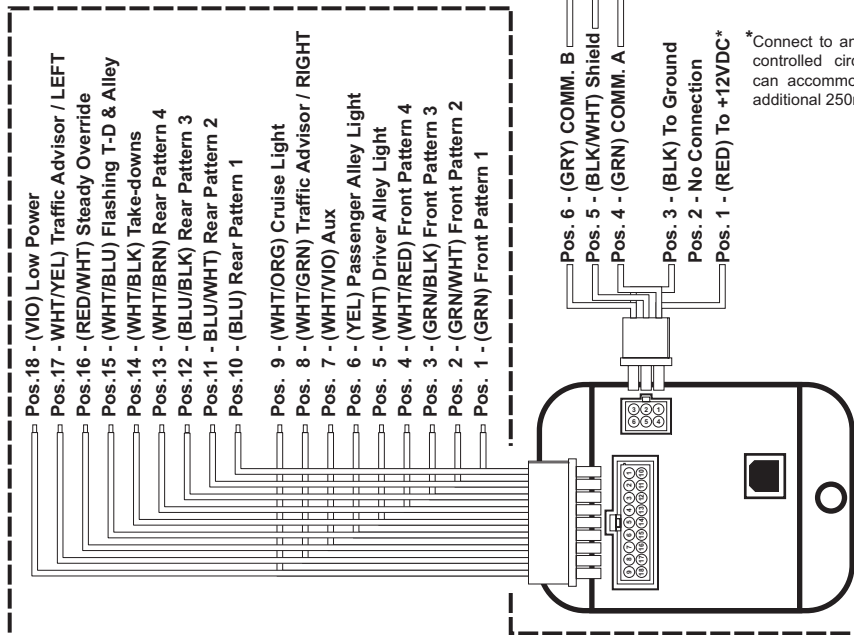
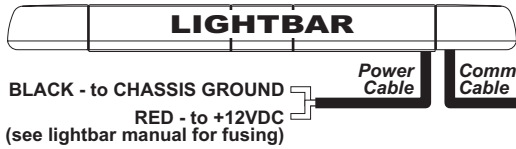

*Connect to an ignition controlled circuit that can accommodate an additional 250mA load.

POS	COLOR	FUNCTION	Connects to...
1	GREEN	FRONT PATTERN 1	Terminal 2 (SS#2)
2	GRN/WHT	FRONT PATTERN 2	Optional
3	GRN/BLK	FRONT PATTERN 3	Optional
4	WHT/RED	FRONT PATTERN 4	Optional
5	WHITE	DRIVER ALLEY	Terminal 7 (PB#2)
6	YELLOW	PASSENGER ALLEY	Terminal 8 (PB#3)
7	WHT/VIO	AUX	Optional
8	WHT/GRN	RIGHT TRAFFIC ADVISOR	Terminal 10 (PH#5)
9	WHT/ORG	CRUISE LIGHTS	OPTIONAL

POS	COLOR	FUNCTION	Connects to...
10	BLUE	REAR PATTERN 1	Terminal 1 (SS#1)
11	BLU/WHT	REAR PATTERN 2	Optional
12	BLU/BLK	REAR PATTERN 3	Optional
13	WHT/BRN	REAR PATTERN 4	Optional
14	WHT/BLK	TAKE-DOWNS	Terminal 6 (PB#1)
15	WHT/BLU	FLASHING TD / ALLEY	Terminal 3 (SS#3)
16	RED/WHT	STEADY OVERRIDE	Optional
17	WHT/YEL	LEFT TRAFFIC ADVISOR	Terminal 9 (PB#4)
18	VIOLET	LOW POWER	Terminal 13 (PB#6)

Example #3: Integrating a WeCan® Control Point Module into a PCCS9NP System.

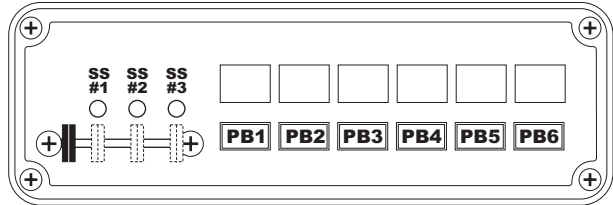
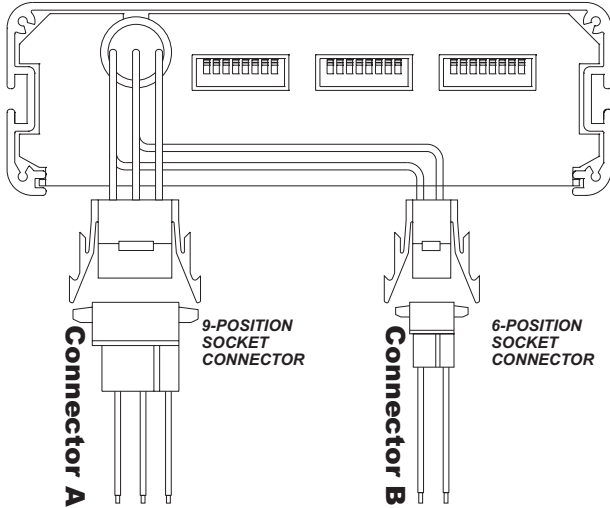

BUTTON	FUNCTION
PB1	Take-downs
PB2	Driver Alley Light
PB3	Passenger Alley Light
PB4	Traffic Advisor™ Left
PB5	Traffic Advisor Right
PB6	Low Power
SS1	Rear
SS2	Front + Rear
SS3	Front + Rear + Flashing Take-Downs

POS	COLOR
POS 1	GREEN - Slide Switch #1
POS 2	BROWN - See PCCS9NP manual
POS 3	VIOLET - PB Switch #9 (mom)
POS 4	BLUE - Slide Switch #3
POS 5	GRY - Slide Switch #2
POS 6	WHT - PB Switch #5
POS 7	YEL - PB Switch #6
POS 8	ORG - PB Switch #7
POS 9	WHT/BLK - PB Switch #4

POS	COLOR
POS 1	RED - See PCCS9NP manual
POS 2	BLACK - Chassis Ground
POS 3	WHT/GRN - To Aux Siren (option)
POS 4	BLK/WHT - PB Switch #8
POS 5	WHT/RED - To +12V (backlight)

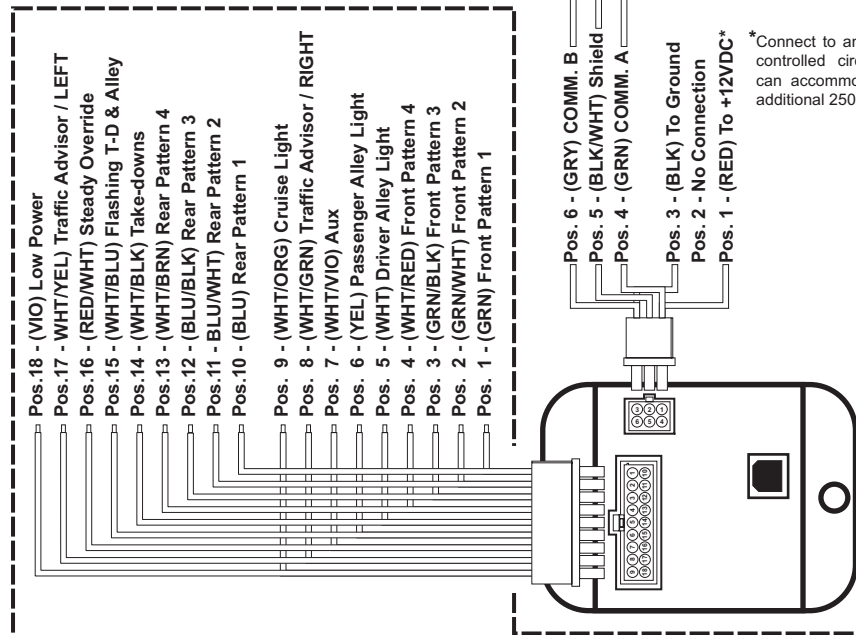
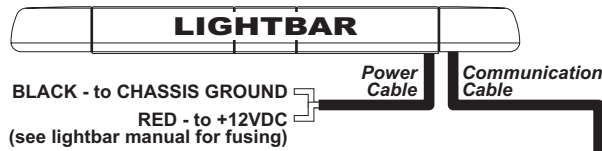

*Connect to an ignition controlled circuit that can accommodate an additional 250mA load.

POS	COLOR	FUNCTION	Connects to...
1	GREEN	FRONT PATTERN 1	Connector A - Pos. 5 (SS#2)
2	GRN/WHT	FRONT PATTERN 2	Optional
3	GRN/BLK	FRONT PATTERN 3	Optional
4	WHT/RED	FRONT PATTERN 4	Optional
5	WHITE	DRIVER ALLEY	Connector A - Pos. 6 (PB#2)
6	YELLOW	PASSENGER ALLEY	Connector A - Pos. 7 (PB#3)
7	WHT/VIO	AUX	Optional
8	WHT/GRN	RIGHT TRAFFIC ADVISOR	Connector B - Pos. 4 (SS#5)
9	WHT/ORG	CRUISE LIGHTS	Optional

POS	COLOR	FUNCTION	Connects to...
10	BLUE	REAR PATTERN 1	Connector A - Pos. 1 (SS#1)
11	BLU/WHT	REAR PATTERN 2	Optional
12	BLU/BLK	REAR PATTERN 3	Optional
13	WHT/BRN	REAR PATTERN 4	Optional
14	WHT/BLK	TAKE-DOWNS	Connector A - Pos. 9 (PB#1)
15	WHT/BLU	FLASHING TD / ALLEY	Optional
16	RED/WHT	STEADY OVERRIDE	Connector A - Pos. 4 (SS#3)
17	WHT/YEL	LEFT TRAFFIC ADVISOR	Connector A - Pos. 8 (PB#4)
18	VIOLET	LOW POWER	Connector A - Pos. 3 (PB#6)