

WHELEN[®]

ENGINEERING COMPANY INC.

51 Winthrop Road
 Chester, Connecticut 06412-0684
 Phone: (860) 526-9504
 Fax: (860) 526-2009
 Internet: www.whelen.com
 Sales/Service e-mail: aviation@whelen.com

Installation Guide: Model 71080()-series Model 7108013 P/N:01-0771080-13 LED Flashing Anti-Collision Light Assembly

TSO-C96a
 CLASS I, III;
 APPROVED



The conditions and tests required for TSO approval of this article are minimum performance standards. It is the responsibility of those installing this article either on or within a specific type or class of aircraft to determine that the aircraft installation conditions are within the TSO standards. TSO articles must have separate approval for installation in aircraft. The article may be installed only if performed under 14 CFR part 43 or the applicable airworthiness requirements.

OPERATING INSTRUCTIONS:

Operational Voltage: 28 VDC nominal
 (Operational from 22-30 VDC)
Average Input Current: 0.45 Amps
Peak Input Current: 2.0 Amps @ .3 Seconds

The Model 71080 series LED anti-collision light assembly meets the requirements of FAR 91.205(c)(3).

EQUIPMENT LIMITATIONS: An approved anti-collision light assembly should be located so that the light will not impair the crew's vision or detract from the conspicuity of the position lights. The baseplate must be mounted parallel to the vertical and horizontal centerlines of the aircraft to project the patterns properly.

Certain types of installations may require additional testing.

CONTINUED AIRWORTHINESS: The 71080 series LED anti-collision light assembly is designed with 8 vertical columns consisting of 4 LEDs each. Should any one LED or any vertical column fail, the unit must be repaired or replaced. Inspect the lens and replace if there is excessive scratching, discoloration or cracking. **NOTE:** To reduce eye strain use an optical filter such as dark glasses or a blue covering dome during LED inspection.

INSTALLATION PROCEDURES: The following information is to assist in the installation of a Whelen LED Flashing Anti-collision Light System.

1. Using the "suggested mounting hole pattern" prepare the aircraft for means to secure the LED Flashing Anti-collision Light assembly. Remove any existing mounting adapters.
2. 28 VDC (+) and (-) ground leads equipped with an appropriate sized breaker to be supplied to the LED Flashing Anti-collision Light Assembly System. Both leads must be connected by an approved FAA connection. Insure that the wire leads are clear of any obstructions and ty-wrap as required. **CAUTION!** Do not touch the LEDs with either fingers or sharp objects. This could soil and/or damage the LED and effect the optical performance of the LEDs.
3. Install the light assembly by securing to the aircraft using appropriate, approved hardware. Refer to page 2.
4. All inverted (bottom) mounted units shall require waterproofing of the flasher base assembly to the aircraft.
5. Check all avionics systems for interference from this installation.
6. A flight check should be performed by a properly certified pilot.
7. Update aircraft records, complete Form 337 and obtain FAA field approval for installation, as required.

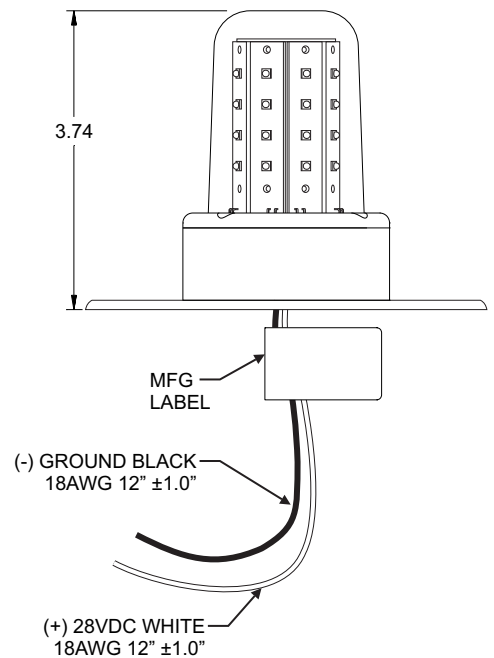
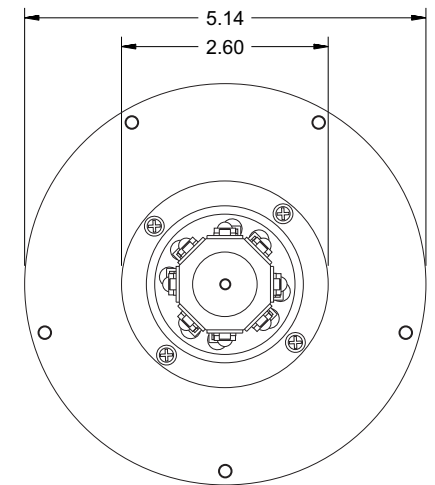

Aviation

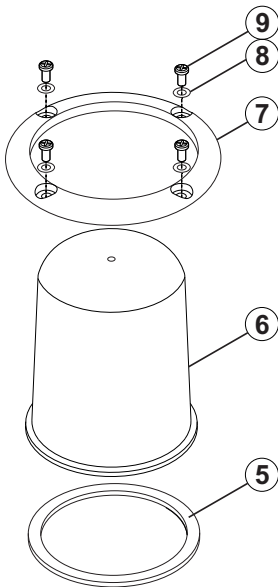

QTY	ITEM	PART NUMBER	DESCRIPTION
*		01-0771080-13	MODEL 7108013 (IRIDITE / 28V)
1	1	07-770907-210	ADAPTER PLATE, 5-HOLE
1	2	01-0271848-00	ASSY, 28V LED ANTI COLLISION LIGHT 71080
4	3	16-0050506136	WASHER, #6 LOCK-SPRING MS35338-136
4	4	14-0050503123	SCREW, 6-32 X 9/16 PPHMS SS MS51957-123
1	5	38-0250885-00	GASKET, LENS MODEL 71055 SERIES
1	6	68-4971082A31	LENS, CLEAR LED ANTI-COL. w/DRAIN HARDCOAT
1	7	19-171047-100	RETAINER, LENS IRIDITE COMPLETE
4	8	16-0050506135	WASHER, #4 LOCK-SPRING MS35338-135
4	9	14-0050505-14	SCREW, 4-40 X 5/16 PPHMS MS51957-14

