

WHELEN[®]

ENGINEERING COMPANY INC.

51 Winthrop Road
Chester, Connecticut 06412-0684
Phone: (860) 526-9504
Fax: (860) 526-4078
Internet: www.whelen.com
Sales e-mail: autosale@whelen.com
Canadian Sales e-mail: canadiansales@whelen.com
Customer Service e-mail: custserv@whelen.com

Installation Guide: TracRac[®] Light

Safety First

This document provides all the necessary information to allow your Whelen product to be properly and safely installed. Before beginning the installation and/or operation of your new product, the installation technician and operator must read this manual completely. Important information is contained herein that could prevent serious injury or damage.

- **Proper installation of this product requires the installer to have a good understanding of automotive electronics, systems and procedures.**
- **If mounting this product requires drilling holes, the installer MUST be sure that no vehicle components or other vital parts could be damaged by the drilling process. Check both sides of the mounting surface before drilling begins. Also de-burr any holes and remove any metal shards or remnants. Install grommets into all wire passage holes.**
- **If this manual states that this product may be mounted with suction cups, magnets, tape or Velcro[™], clean the mounting surface with a 50/50 mix of isopropyl alcohol and water and dry thoroughly.**
- **Do not install this product or route any wires in the deployment area of your air bag. Equipment mounted or located in the air bag deployment area will damage or reduce the effectiveness of the air bag, or become a projectile that could cause serious personal injury or death. Refer to your vehicle owners manual for the air bag deployment area. The User/Installer assumes full responsibility to determine proper mounting location, based on providing ultimate safety to all passengers inside the vehicle.**
- **For this product to operate at optimum efficiency, a good electrical connection to chassis ground must be made. The recommended procedure requires the product ground wire to be connected directly to the NEGATIVE (-) battery post.**
- **If this product uses a remote device to activate or control this product, make sure that this control is located in an area that allows both the vehicle and the control to be operated safely in any driving condition.**
- **Do not attempt to activate or control this device in a hazardous driving situation.**
- **This product contains either strobe light(s), halogen light(s), high-intensity LEDs or a combination of these lights. Do not stare directly into these lights. Momentary blindness and/or eye damage could result.**
- **Use only soap and water to clean the outer lens. Use of other chemicals could result in premature lens cracking (crazing) and discoloration. Lenses in this condition have significantly reduced effectiveness and should be replaced immediately. Inspect and operate this product regularly to confirm its proper operation and mounting condition. Do not use a pressure washer to clean this product.**
- **It is recommended that these instructions be stored in a safe place and referred to when performing maintenance and/or reinstallation of this product.**
- **FAILURE TO FOLLOW THESE SAFETY PRECAUTIONS AND INSTRUCTIONS COULD RESULT IN DAMAGE TO THE PRODUCT OR VEHICLE AND/OR SERIOUS INJURY TO YOU AND YOUR PASSENGERS!**

For warranty information regarding this product, visit www.whelen.com/warranty

Installation:

1. Remove the 4 phillips sheet metal screws that hold the top housing on and then carefully pull the top and bottom of the housing apart.
2. Remove the end cap from the light rack (Fig. 1).

WARNING: Do not tug on lighthouse wires. Damage may occur.

Fig. 1

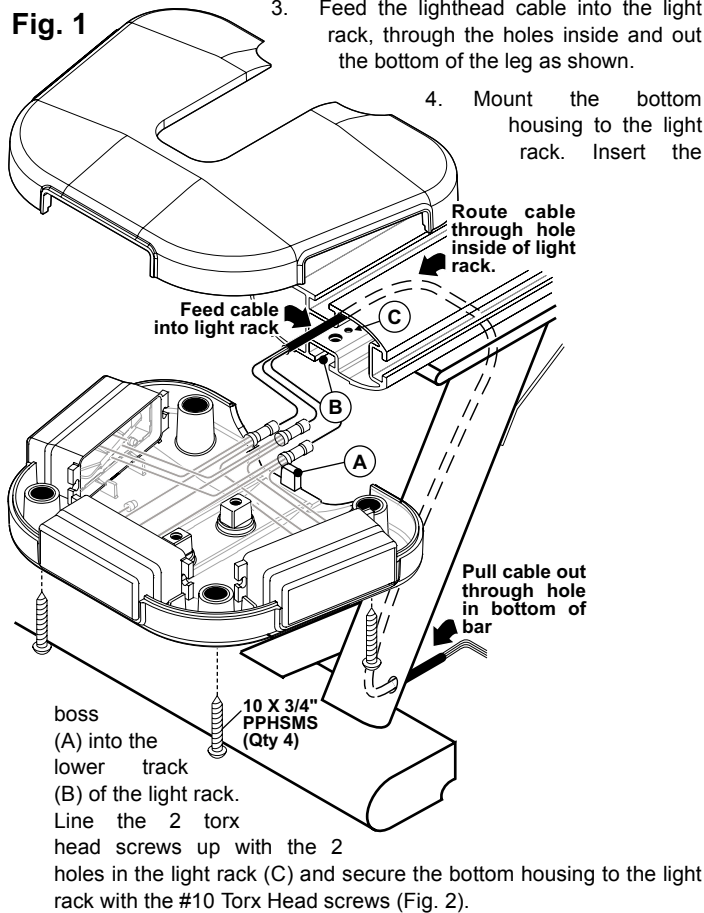

3. Feed the lighthouse cable into the light rack, through the holes inside and out the bottom of the leg as shown.
4. Mount the bottom housing to the light rack. Insert the
5. Secure the top of the light housing using the 4 sheet metal screws that you removed in step 2. Be careful not to pinch the wires in the process (Fig. 2).
6. Extend the wires to your power source and installation is complete.

Wiring:

WARNING! All customer supplied wires that connect to the positive terminal of the battery must be sized to supply at least 125% of the maximum operating current and FUSED at the battery to carry that load. DO NOT USE CIRCUIT BREAKERS WITH THIS PRODUCT!

Extend the BLACK wire to a ground and the RED wire to +12 VDC. Fuse the RED wire at 5 amps (A customer supplied switch is recommended). Connect the GREEN (SYNC) wire to the SYNC wire of other SYNC capable lighting options or with the opposite rack light.

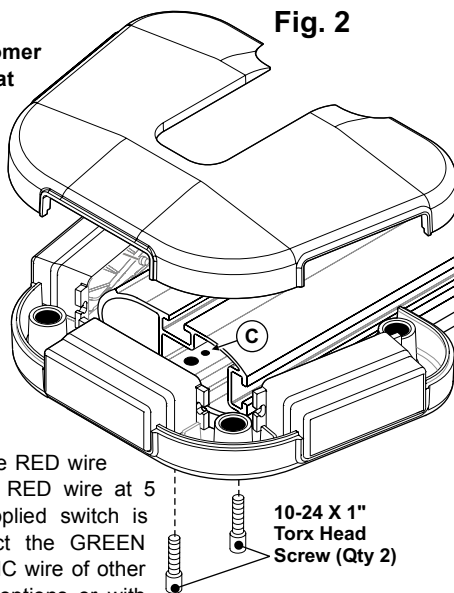

Operation:

When you apply power to the RED wire all lighthoods will run in the SignaAlert™ 75 flash pattern.

SYNC: The GREEN wire is for SYNC. When you connect the GREEN wire to the SYNC wire of other SYNC capable lights, this unit will flash simultaneously or alternately with them.

IMPORTANT WARNING!

CAUTION! DO NOT LOOK DIRECTLY AT THESE LED'S WHILE THEY ARE ON. MOMENTARY BLINDNESS AND/OR EYE DAMAGE COULD RESULT!

IMPORTANT! Before returning the vehicle to active service, visually confirm the proper operation of this product, as well as all vehicle components and equipment.

IMPORTANT! It is the responsibility of the installation technician to make sure that the installation and operation of this product will not interfere with or compromise the operation or the efficiency of any vehicle equipment!

QTY	QTY	QTY	QTY	QTY	QTY	ITEM	PART NUMBER	DESCRIPTION
				*			01-0686069D_1	Trac-Rac LT / 1 LED / DRIVR / Trac-Rac EXT.
				*			01-0686069D_2	Trac-Rac LT / 2 LED / DRIVR / Trac-Rac EXT.
		*					01-0686069D_3	Trac-Rac LT / 3 LED / DRIVR / Trac-Rac EXT.
		*					01-0686069P_1	Trac-Rac LT / 1 LED / PASS. / Trac-Rac EXT.
		*					01-0686069P_2	Trac-Rac LT / 2 LED / PASS. / Trac-Rac EXT.
*							01-0686069P_3	Trac-Rac LT / 3 LED / PASS. / Trac-Rac EXT.
-	-	-	1	1	1	1	11-486017-D00	HOUSING / BOTTOM DRIVR / Trac-Rac EXT.
1	1	1	-	-	-	2	11-486017-P00	HOUSING / BOTTOM PASS. / Trac-Rac EXT.
A/R	A/R	A/R	A/R	A/R	A/R	3	01-026C254-14	ASSY / LIN3 LED / SYNC / AMBER
A/R	A/R	A/R	A/R	A/R	A/R	4	01-026C254-24	ASSY / LIN3 LED / SYNC / BLUE
A/R	A/R	A/R	A/R	A/R	A/R	5	01-026C254-34	ASSY / LIN3 LED / SYNC / WHITE
A/R	A/R	A/R	A/R	A/R	A/R	6	01-026C254-44	ASSY / LIN3 LED / SYNC / GREEN
A/R	A/R	A/R	A/R	A/R	A/R	7	01-026C254-54	ASSY / LIN3 LED / SYNC / RED
-	1	2	-	1	2	8	68-3964759-90	LENS / BLACK LINEAR 3
-	-	3	-	-	3	9	25-0022214-01	BUTT SPLICE / 22-18 AWG WATERPROOF
3	3	-	3	3	-	10	25-1510223-00	B. SPLICE / STP-DWN 16-14 AWG TO 22-18 AWG / PERM
3	2	1	3	2	1	11	25-0910223-05	BUTT TAIL / 22-14 GA, INS
-	-	-	1	1	1	12	11-486016-D00	HOUSING / TOP DRIVR / Trac-Rac EXT.
1	1	1	-	-	-	13	11-486016-P00	HOUSING / TOP PASS. / Trac-Rac EXT.
4	4	4	4	4	4	14	15-101416-120	SCREW / 10 x 3/4" PPHSMS
2	2	2	2	2	2	15	14-104286-163	SCREW / 10-24 x 1" TORX
1	1	1	1	1	1	16	46-0743658-00	CABLE / 4-C 18 GA TPR / 15' / 4" / Trac-Rac

PART NUMBER KEY	LED Quantity	LED COLOR	LED QUANTITY	COLOR	LIGHTHEAD POSITION
01-0686069	1 = One LED	1 = Amber	1 = One LED	4 = Green	D = Driver Side
	2 = Two LEDs	2 = Blue	2 = Two LEDs	5 = Red	P = Passenger Side
	3 = Three LEDs	3 = Clear	3 = Three LEDs		

