

# WHELEN<sup>®</sup>

## ENGINEERING COMPANY INC.

51 Winthrop Road  
Chester, Connecticut 06412-0684  
Phone: (860) 526-9504  
Fax: (860) 526-4078  
Internet: [www.whelen.com](http://www.whelen.com)  
Sales e-mail: [autosale@whelen.com](mailto:autosale@whelen.com)  
Canadian Sales e-mail: [canadiansales@whelen.com](mailto:canadiansales@whelen.com)  
Customer Service e-mail: [custserv@whelen.com](mailto:custserv@whelen.com)

### Installation Guide: Mini Justice<sup>®</sup> Lightbar

#### Warnings to Installers

Whelen's emergency vehicle warning devices must be properly mounted and wired in order to be effective and safe. Read and follow all of Whelen's written instructions when installing or using this device. Emergency vehicles are often operated under high speed stressful conditions which must be accounted for when installing all emergency warning devices. Controls should be placed within convenient reach of the operator so that they can operate the system without taking their eyes off the roadway. Emergency warning devices can require high electrical voltages and/or currents. Properly protect and use caution around live electrical connections. Grounding or shorting of electrical connections can cause high current arcing, which can cause personal injury and/or vehicle damage, including fire. Many electronic devices used in emergency vehicles can create or be affected by electromagnetic interference. Therefore, after installation of any electronic device it is necessary to test all electronic equipment simultaneously to insure that they operate free of interference from other components within the vehicle. Never power emergency warning equipment from the same circuit or share the same grounding circuit with radio communication equipment. All devices should be mounted in accordance with the manufacturer's instructions and securely fastened to vehicle elements of sufficient strength to withstand the forces applied to the device. Driver and/or passenger air bags (SRS) will affect the way equipment should be mounted. This device should be mounted by permanent installation and within the zones specified by the vehicle manufacturer, if any. Any device mounted in the deployment area of an air bag will damage or reduce the effectiveness of the air bag and may damage or dislodge the device. Installer must be sure that this device, its mounting hardware and electrical supply wiring does not interfere with the air bag or the SRS wiring or sensors. Mounting the unit inside the vehicle by a method other than permanent installation is not recommended as unit may become dislodged during swerving; sudden braking or collision. Failure to follow instructions can result in personal injury. Whelen assumes no liability for any loss resulting from the use of this warning device. PROPER INSTALLATION COMBINED WITH OPERATOR TRAINING IN THE PROPER USE OF EMERGENCY WARNING DEVICES IS ESSENTIAL TO INSURE THE SAFETY OF EMERGENCY PERSONNEL AND THE PUBLIC.

#### Warnings to Users

Whelen's emergency vehicle warning devices are intended to alert other operators and pedestrians to the presence and operation of emergency vehicles and personnel. However, the use of this or any other Whelen emergency warning device does not guarantee that you will have the right-of-way or that other drivers and pedestrians will properly heed an emergency warning signal. Never assume you have the right-of-way. It is your responsibility to proceed safely before entering an intersection, driving against traffic, responding at a high rate of speed, or walking on or around traffic lanes. Emergency vehicle warning devices should be tested on a daily basis to ensure that they operate properly. When in actual use, the operator must ensure that both visual and audible warnings are not blocked by vehicle components (i.e.: open trunks or compartment doors), people, vehicles, or other obstructions. It is the user's responsibility to understand and obey all laws regarding emergency warning devices. The user should be familiar with all applicable laws and regulations prior to the use of any emergency vehicle warning device. Whelen's audible warning devices are designed to project sound in a forward direction away from the vehicle occupants. However, because sustained periodic exposure to loud sounds can cause hearing loss, all audible warning devices should be installed and operated in accordance with the standards established by the National Fire Protection Association.

#### Safety First

This document provides all the necessary information to allow your Whelen product to be properly and safely installed. Before beginning the installation and/or operation of your new product, the installation technician and operator must read this manual completely. Important information is contained herein that could prevent serious injury or damage.

- **Proper installation of this product requires the installer to have a good understanding of automotive electronics, systems and procedures.**
- **Whelen Engineering requires the use of waterproof butt splices and/or connectors if that connector could be exposed to moisture.**
- **Failure to use specified installation parts and/or hardware will void the product warranty.**
- **If mounting this product requires drilling holes, the installer MUST be sure that no vehicle components or other vital parts could be damaged by the drilling process. Check both sides of the mounting surface before drilling begins. Also de-burr the holes and remove any metal shards or remnants. Install grommets into all wire passage holes.**
- **If this manual states that this product may be mounted with suction cups, magnets, tape or Velcro<sup>®</sup>, clean the mounting surface with a 50/50 mix of isopropyl alcohol and water and dry thoroughly.**
- **Do not install this product or route any wires in the deployment area of your air bag. Equipment mounted or located in the air bag deployment area will damage or reduce the effectiveness of the air bag, or become a projectile that could cause serious personal injury or death. Refer to your vehicle owner's manual for the air bag deployment area. The User/Installer assumes full responsibility to determine proper mounting location, based on providing ultimate safety to all passengers inside the vehicle.**
- **For this product to operate at optimum efficiency, a good electrical connection to chassis ground must be made. The recommended procedure requires the product ground wire to be connected directly to the NEGATIVE (-) battery post (this does not include products that use cigar power cords).**
- **If this product uses a remote device for activation or control, make sure that this device is located in an area that allows both the vehicle and the device to be operated safely in any driving condition.**
- **Do not attempt to activate or control this device in a hazardous driving situation.**
- **This product contains either strobe light(s), halogen light(s), high-intensity LEDs or a combination of these lights. Do not stare directly into these lights. Momentary blindness and/or eye damage could result.**
- **Use only soap and water to clean the outer lens. Use of other chemicals could result in premature lens cracking (crazing) and discoloration. Lenses in this condition have significantly reduced effectiveness and should be replaced immediately. Inspect and operate this product regularly to confirm its proper operation and mounting condition. Do not use a pressure washer to clean this product.**
- **It is recommended that these instructions be stored in a safe place and referred to when performing maintenance and/or reinstallation of this product.**
- **FAILURE TO FOLLOW THESE SAFETY PRECAUTIONS AND INSTRUCTIONS COULD RESULT IN DAMAGE TO THE PRODUCT OR VEHICLE AND/OR SERIOUS INJURY TO YOU AND YOUR PASSENGERS!**

**IMPORTANT! The lightbar should be a minimum of 16" from any radio antennas!**

**Permanent Mounting:**

1. Locate the mounting foot and mounting plate included with your lightbar. If not already present, install the plate onto the mounting foot. When properly positioned, this plate is centered from side to side on the mounting foot.
2. Flip the lightbar upside-down to expose the bottom of the extrusion and place the mounting foot onto the extrusion.
3. Rotate the mounting foot 90° counter-clockwise. Make sure that the edges of the mounting foot swing into position under the extrusion mounting lip.
4. Repeat this procedure for the remaining mounting foot and return the lightbar to its right side-up position.
5. Position the lightbar onto the vehicle roof in the desired mounting location. One often selected location is directly above the B-pillars. This area is the strongest part of the roof. Refer to your lightbar manual for your lightbars cable exit location, to be sure that the lightbar is facing the proper direction.
6. Adjust the two mounting feet outwards so that they are as close to the edge of the roof as possible. Make sure that both mounting feet are in full contact with the roof. Be sure that there is no less than 1/2" clearance between the roof and the lightbar at their closest point. When the mounting feet are in their proper position, lightly tighten the mounting foot allen head set screws.
7. Turn the lightbar upside down and tighten all of the set screws from step 6 (2 or 4 per side) to 14-16 In. Lbs..
8. Note that on the adjustable foot, use the hole in the pad as a guide to drill the two holes into the mounting foot at the locations shown.
9. Place the lightbar in its final mounting position on the vehicle, mark the mounting hole locations off onto the mounting surface, remove the lightbar and drill the mounting holes.
10. Place the lightbar back onto the vehicle lined up with the mounting holes and secure the mounting feet to the vehicle using the supplied hardware.

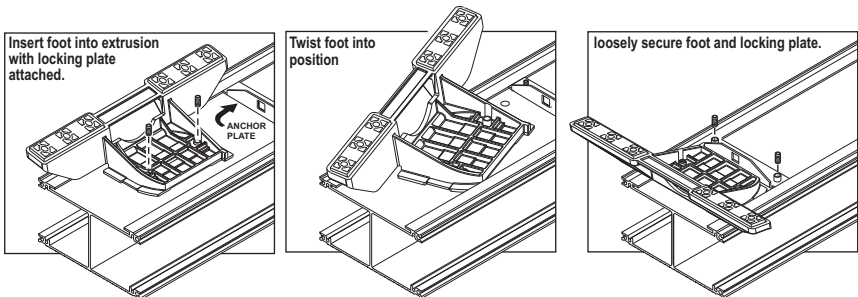
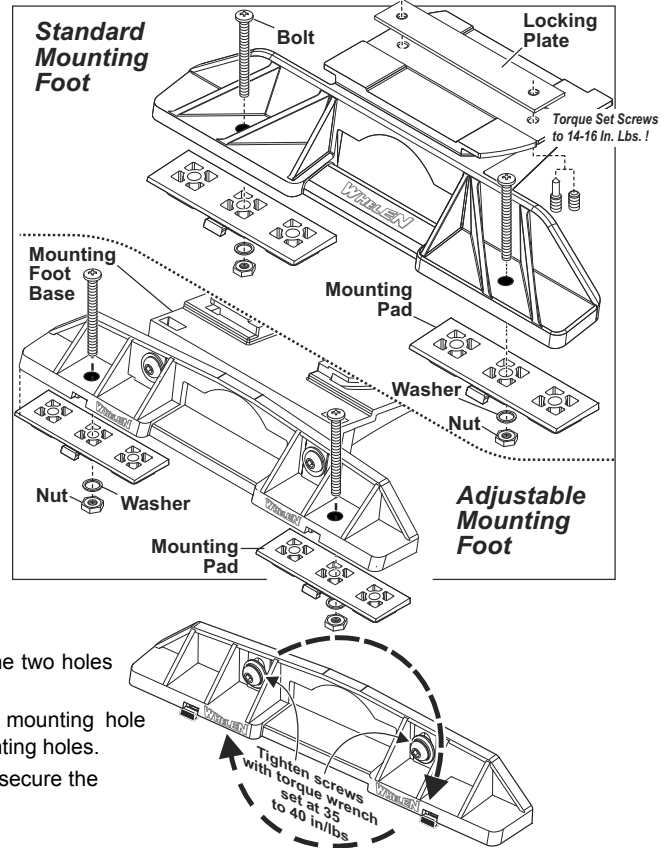

**NOTE: Model MKAJ is an adjustable mounting foot. On this model you may loosen the screws on the rear of the foot and adjust the angle of the lightbar. This feature can be used if the angle of the roof is not level with the road.**

**IMPORTANT: To tighten the leveling screws you must use a torque wrench set at 35 to 40 ft. lbs.**

**Slide Bolt Mounting (Permanent):**

1. Position the slide bolt mounting plates onto the bottom of the lightbar extrusion. These plates rotate into position the same way as the mounting foot. Position the plates as far outward as possible (if a 3rd mounting plate is used, it should be positioned under the center of the lightbar).
1. Secure the plates to the extrusion using the set screws provided.
2. Position the lightbar onto the vehicle and mark the mounting bolt locations. Drill the necessary mounting holes using an appropriately sized drill bit sized for a 1/2" bolt.

**Temporary Mount (Magnetic, Suction Cup):**

**WARNING: The use of any magnetically mounted warning device on the outside of a vehicle in motion is not recommended and is at the sole risk and responsibility of the user.**

**Magnetic/suction:** Thoroughly clean the mounting surface prior to mounting. For suction cup mounting, wipe the suction cup clean, place the beacon onto the mounting surface and apply gentle pressure to ensure a good seal has been achieved. The Magnetic/Suction Cups mount the same as standard suction cups but are best suited to a flat, steel surface.

**Magnetic:** Place the lightbar onto the mounting surface and plug it into the vehicle cigar lighter.

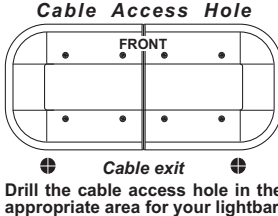

## Lightbar Cable:

The standard lightbar uses an 11 conductor cable for LED's and Halogens as well as power and function. Extend the cable towards your switch panel and follow the switch panel instructions for wiring connections. Cigar cord models do not offer Low Power or Pattern Override. On cigar plug models Scan-Lock™ is controlled by a momentary switch on the cigar plug.

**WARNING! All Customer supplied wires that connect to the positive terminal of the battery must be sized to supply at least 125% of the maximum operating current and FUSED at the battery to carry that load. DO NOT USE CIRCUIT BREAKERS WITH THIS PRODUCT!**

## WHITE/VIOLET: Scan-Lock™

LED's must be on for Scan-Lock™ to work.

**TO CHANGE PATTERNS:** To cycle forward to the next available pattern: Apply +12 volts to the WHT/VIO wire for less than 1 second and release. To cycle back to the previous pattern: Apply +12 volts to the WHT/VIO wire for more than 1 second and release.

**TO CHANGE THE DEFAULT PATTERN:** When the desired pattern is active, allow it to run for over 5 seconds. The lightbar will now display this pattern when activated.

**TO RESTORE THE FACTORY DEFAULT PATTERN:** With power to the lighthoods off, apply +12 volts to the WHT/VIO wire. While still applying +12 volts to the WHT/VIO wire, turn power to the lighthoods back on. The factory default pattern should now be displayed.

A Normally Open momentary switch can be used to control Scan-Lock™ operation. Cigar cord models have a switch on the cigar plug.

## IMPORTANT WARNING!

**CAUTION! DO NOT LOOK DIRECTLY AT THESE LED'S WHILE THEY ARE ON. MOMENTARY BLINDNESS AND/OR EYE DAMAGE COULD RESULT!**

## Violet / Low Power:

The type of switch used depends on how you wish Hi/Lo to function:

**Latching Mode:** Apply positive voltage to the VIOLET wire for less than 1 sec., the lightbar is "latched" into low power. The lightbar must be turned off and then back on

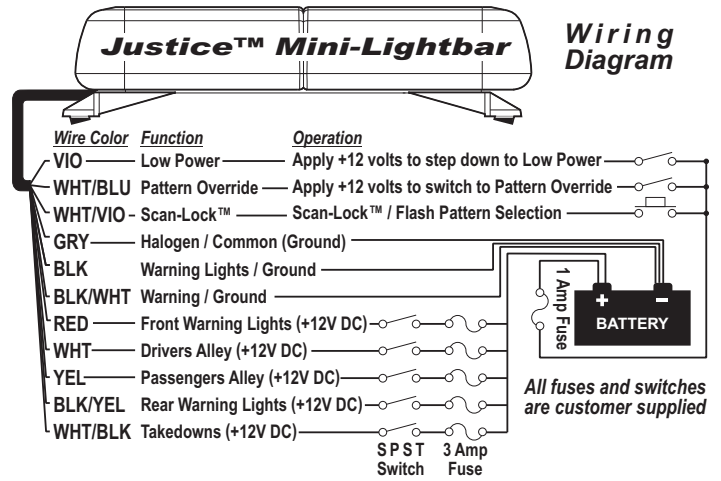

to restore normal operation. (A momentary switch is preferred)

**Level Mode:** Applying positive voltage to the VIOLET wire for more than 1 sec. holds the lightbar in low power mode until voltage is removed. (A toggle switch is preferred)

## WHITE/BLUE: Pattern Override

Applying +12 volts to the WHT/BLU wire while lighthoods are activated will change the flash pattern to whichever flash pattern that pattern override is pre-programmed for. To program pattern override, activate the lightbar then activate pattern override by applying +12 volts to the WHT/BLU wire. Now you may select a flash pattern using the Scan-Lock™ procedure.

**IMPORTANT!** Before returning this vehicle to active service, visually confirm the proper operation of this product, as well as all vehicle components/equipment.

**IMPORTANT!** It is the responsibility of the installation technician to make sure that the installation and operation of this product will not interfere with or compromise the operation or efficiency of any vehicle equipment!

## Available Flash Patterns:

- |                                |                                 |                             |                               |                              |
|--------------------------------|---------------------------------|-----------------------------|-------------------------------|------------------------------|
| 1. ActionScan™ - Alt           | 16. SingleFlash 120 Alt/Sync *  | 32. SignalAlert™ 75 In/Out  | 48. LongBurst™ 75 In/Out      | 64. SingleFlash 120 Alt *    |
| 2. SignalAlert™ 75 - Alt/Sync  | 17. SingleFlash 120 Frnt/Rear * | 33. SignalAlert™ 75 Checker | 49. LongBurst™ 75 Checker     | 65. SingleFlash 300 Checker  |
| 3. SignalAlert™ 75 - Frnt/Rear | 18. SingleFlash 300 Alt/Sync    | 34. SignalAlert™ 75 4 Cycle | 50. LongBurst™ 75 4 Cycle     | 66. SingleFlash 300 4 Cycle  |
| 4. CometFlash® 75 Alt/Sync     | 19. SingleFlash 300 Frnt/Rear   | 35. SignalAlert™ 75 Alt     | 51. LongBurst™ 75 Alt         | 67. SingleFlash 300 Alt      |
| 5. CometFlash® 75 Frnt/Rear    | 20. DoubleFlash 120 Alt/Sync    | 36. CometFlash® 75 In/Out   | 52. SingleFlash 60 In/Out *   | 68. DoubleFlash 120 In/Out   |
| 6. DoubleFlash 75 Alt/Sync     | 21. DoubleFlash 120 Frnt/Rear   | 37. CometFlash® 75 Checker  | 53. SingleFlash 60 Checker *  | 69. DoubleFlash 120 Checker  |
| 7. DoubleFlash 75 Frnt/Rear    | 22. ActionFlash™ 50 Alt/Sync    | 38. CometFlash® 75 4 Cycle  | 54. SingleFlash 60 4 Cycle *  | 70. DoubleFlash 120 4 Cycle  |
| 8. SingleFlash 75 Alt/Sync     | 23. ActionFlash™ 50 Frnt/Rear   | 39. CometFlash® 75 Alt      | 55. SingleFlash 60 Alt *      | 71. DoubleFlash 120 4 Cycle  |
| 9. SingleFlash 75 Frnt/Rear    | 24. ActionFlash™ 150 Alt/Sync   | 40. DoubleFlash 75 In/Out   | 56. SingleFlash 90 In/Out *   | 72. ActionFlash™ 50 In/Out   |
| 10. LongBurst™ 75 Alt/Sync     | 25. ActionFlash™ 150 Frnt/Rear  | 41. DoubleFlash 75 Checker  | 57. SingleFlash 90 Checker *  | 73. ActionFlash™ 50 Checker  |
| 11. LongBurst™ 75 Frnt/Rear    | 26. PingPong™ 75 Alt/Sync       | 42. DoubleFlash 75 4 Cycle  | 58. SingleFlash 90 4 Cycle *  | 74. ActionFlash™ 50 4 Cycle  |
| 12. SingleFlash 60 Alt/Sync *  | 27. PingPong™ 75 Frnt/Rear      | 43. DoubleFlash 75 Alt      | 59. SingleFlash 90 Alt *      | 75. ActionFlash™ 50 Alt      |
| 13. SingleFlash 60 Frnt/Rear * | 28. FlimFlam Alt/Sync           | 44. SingleFlash 75 In/Out   | 60. SingleFlash 120 In/Out *  | 76. ActionFlash™ 150 In/Out  |
| 14. SingleFlash 90 Alt/Sync *  | 29. FlimFlam Frnt/Rear          | 45. SingleFlash 75 Checker  | 61. SingleFlash 120 Checker * | 77. ActionFlash™ 150 Checker |
| 15. SingleFlash 90 Frnt/Rear * | 30. ModuFlash™ Alt/Sync         | 46. SingleFlash 75 4 Cycle  | 62. SingleFlash 120 Checker * | 78. ActionFlash™ 150 4 Cycle |
|                                | 31. ModuFlash™ Frnt/Rear        | 47. SingleFlash 75 Alt      | 63. SingleFlash 120 4 Cycle * | 79. ActionFlash™ 150 Alt     |

Alt = Alternating Frnt/Rear = Front to Rear Alt/Sync = Alternating/Synchronized In/Out = ? Checker = Checkerboard Pattern 4 Cycle = Rotates: Alternating, Front-Rear, In-Out and Checkerboard  
\* = California Title XIII Compliant

## LR11 / Removal & Installation / Alley Light

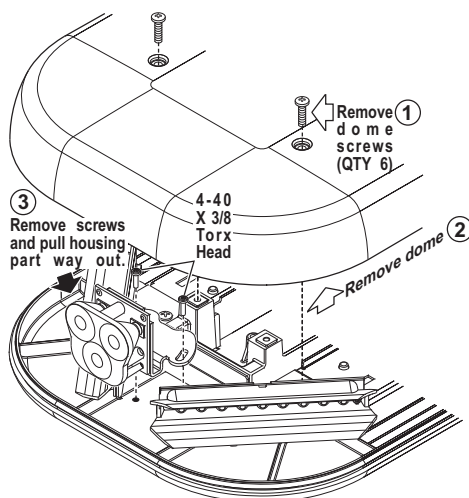

## CON3 LED

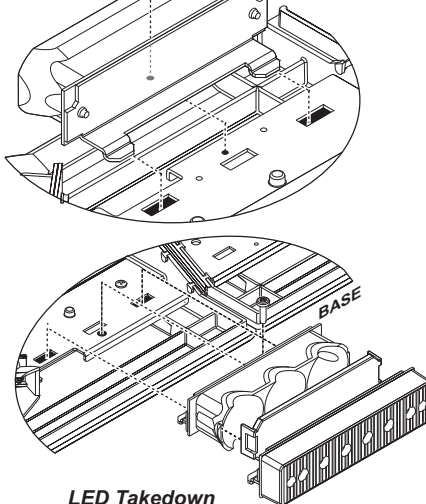

## LR-11 LED / Angle Adjustment

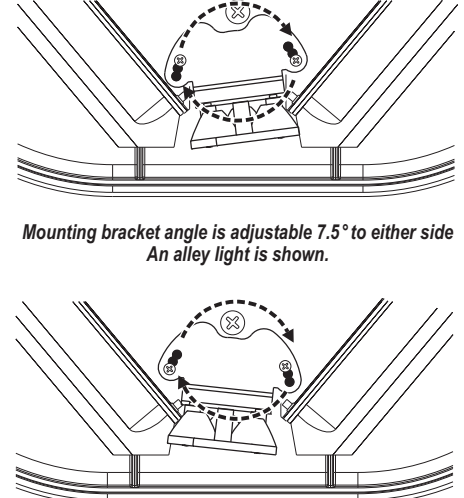

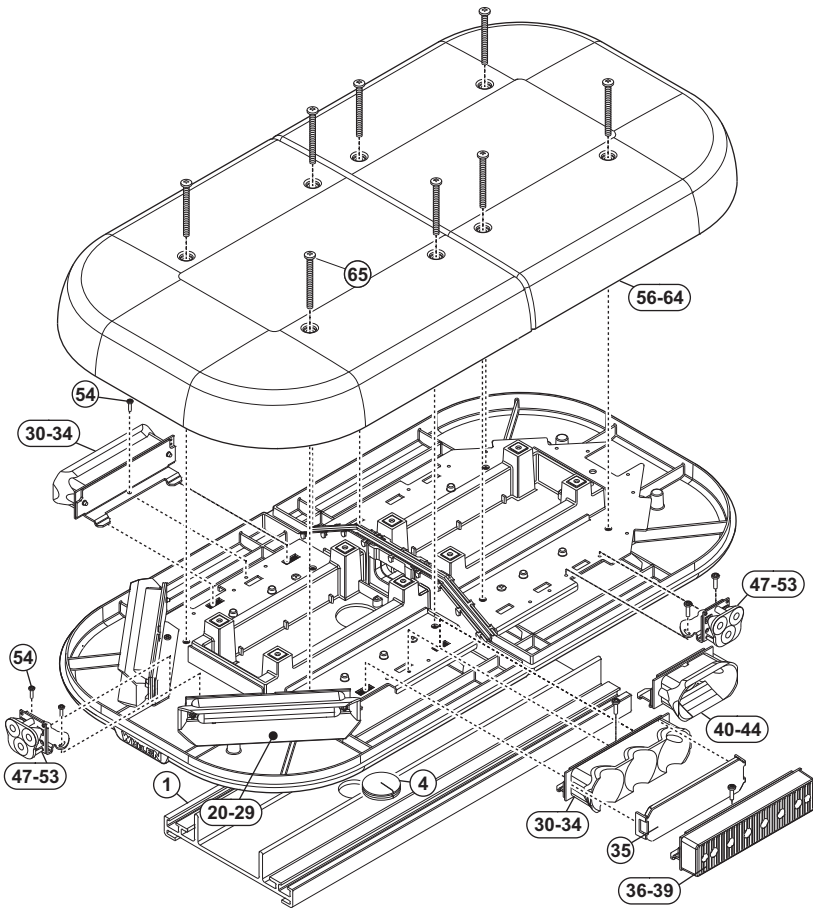

### Optional Lighthoods and Mounting

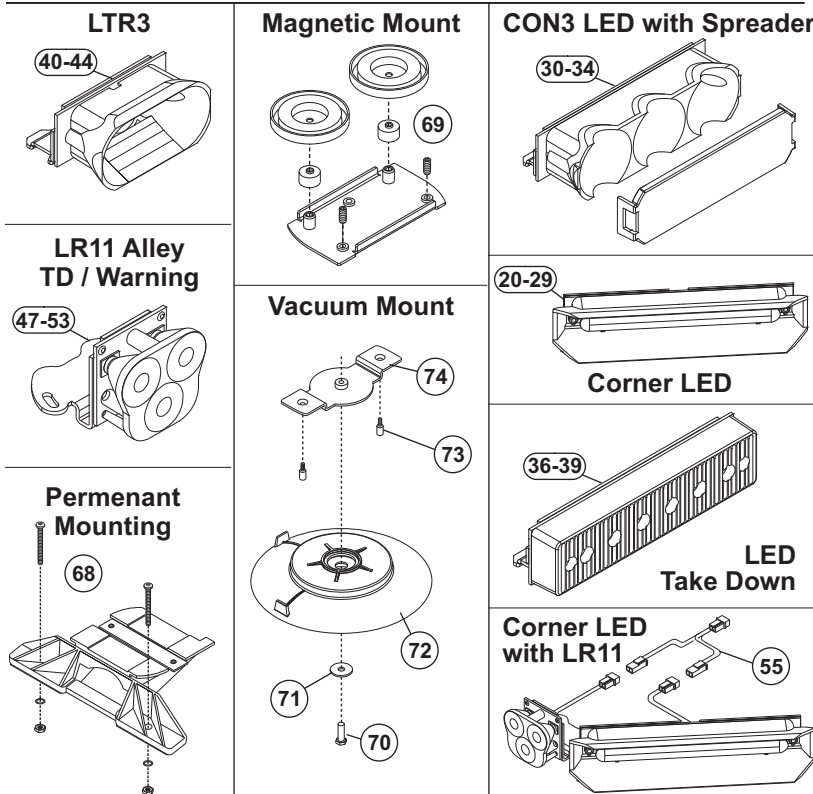

QTY	QTY	QTY	ITEM	PART NUMBER	DESCRIPTION
	*			01-0686098-__	Mini Justice®, 23" Lightbar, PERM MT
	*			01-0686098-__	Mini Justice®, 23" Lightbar, MAGNETIC MT
*				01-0686098-__	Mini Justice®, 23" Lightbar, VACUUM MT
1	1	1	1	11-36A916-014	EXTRUSION, 14.875 W/HOLES
1	1	1	2	02-036A914-91	BASE, W/SEAL, WITH HOLE
1	1	1	3	02-036A914-90	BASE, W/SEAL, WITHOUT HOLE
1	1	1	4	21-11245004-1	GROMMET, TO BE MOLDED 1.562" RUBBER
2	2	2	5	07-286040-000	BRACKET, MTG LTHD SHRT END JUSTICE LTBAR
12	12	12	6	21-17060704-3	GROMMET, ITW FASTEX PLASTI
6	6	6	7	15-101416-080	SCREW, 10 X 1/2 PPHSMS 410 SS
1	1	1	8	38-0443429-30	DIVIDER, BRIDGE CLEAR JUSTICE SERIES
1	1	1	9	38-0464988-00	SEAL, DIVIDER JUSTICE SERIES
-	-	1	10	46-0742901-00	INPUT CABLE 11/C COMP 17' EDGE 9M SERIES
-	-	1	11	39-0412023-04	HSNG, 12 POS SKT F/H COMM MATE-N-LOK
1	1	-	12	02-0243700-00	CIGAR CORD STRAIGHT 10' W/SCKTS 3 SWITCH
1	1	1	13	07-243693-000	BRACKET, STRAIN RELIEF, JUSTICE MINI
3	3	3	14	15-045410-060	SCREW, 4-20 X 3/8" PPH THDFORM PLASTI-LOK, BLK
1	1	1	15	26-0215001-06	TY-WRAP 6" BLACK
-	-	1	16	02-016A934-00	PCB I/O BD WIRED, MINI JUSTICE
1	1	-	17	02-016A911-00	PCB MINI JUSTICE I/O BD CIG CORD
2	2	2	18	46-076A959-00	HARNESS INTERNAL, MINI JUSTICE BAR
A/R	A/R	A/R	19	46-076A960-00	HARNESS TAKEDOWN/ALLEY, MINI JUSTICE
A/R	A/R	A/R	20	01-026B704-16	SUB ASY, 6 LED CORNER AMB JUSTICE SERIES
A/R	A/R	A/R	21	01-026B704-26	SUB ASY, 6 LED CORNER BLU JUSTICE SERIES
A/R	A/R	A/R	22	01-026B704-36	SUB ASY, 6 LED CORNER WHT JUSTICE SERIES
A/R	A/R	A/R	23	01-026B704-46	SUB ASY, 6 LED CORNER GRN JUSTICE SERIES
A/R	A/R	A/R	24	01-026B704-56	SUB ASY, 6 LED CORNER RED JUSTICE SERIES
A/R	A/R	A/R	25	01-026B704-19	SUB ASY, 9 LED CORNER AMB JUSTICE SERIES
A/R	A/R	A/R	26	01-026B704-29	SUB ASY, 9 LED CORNER BLU JUSTICE SERIES
A/R	A/R	A/R	27	01-026B704-39	SUB ASY, 9 LED CORNER WHT JUSTICE SERIES
A/R	A/R	A/R	28	01-026B704-49	SUB ASY, 9 LED CORNER GRN JUSTICE SERIES
A/R	A/R	A/R	29	01-026B704-59	SUB ASY, 9 LED CORNER RED JUSTICE SERIES
A/R	A/R	A/R	30	01-026B568-10	SUB ASY, ECO 3 LED AMB no LENS HINGE JUSTICE
A/R	A/R	A/R	31	01-026B568-20	SUB ASY, ECO 3 LED BLU no LENS HINGE JUSTICE
A/R	A/R	A/R	32	01-026B568-30	SUB ASY, ECO 3 LED WHT no LENS HINGE JUSTICE
A/R	A/R	A/R	33	01-026B568-40	SUB ASY, ECO 3 LED GRN no LENS HINGE JUSTICE
A/R	A/R	A/R	34	01-026B568-50	SUB ASY, ECO 3 LED RED no LENS HINGE JUSTICE
A/R	A/R	A/R	35	68-1984766-30	LENS, CLR OPTIC CONICAL 3 JUSTICE SERIES
-	-	A/R	36	01-026A591-00	SUB ASY, LED TD 12V NON OPTIC 45lm JUSTICE
-	-	A/R	37	01-026A591-01	SUB ASSY, LED TD 12V OPTIC 45lm JUSTICE
-	-	A/R	38	01-026A591-06	SUB ASY, LED TD 12V NON OPTIC 100lm JUSTICE
-	-	A/R	39	01-026A591-07	SUB ASY, LED TD 12V OPTIC 100lm JUSTICE
-	-	A/R	40	01-026A238-10	SUB ASY, DELUXE 3 LED AMB HINGD JUSTICE
-	-	A/R	41	01-026A238-20	SUB ASY, DELUXE 3 LED BLU HINGED JUSTICE
-	-	A/R	42	01-026A238-30	SUB ASY, DELUXE 3 LED WHT HINGED JUSTICE
-	-	A/R	43	01-026A238-40	SUB ASY, DELUXE 3 LED GRN HINGED JUSTICE
-	-	A/R	44	01-026A238-50	SUB ASY, DELUXE 3 LED RED HINGED JUSTICE
-	-	A/R	47	01-026A752-00	SUB ASY, LR11 WHITE JUSTICE 45lm
-	-	A/R	48	01-026A752-01	SUB ASY, LR11 WHITE JUSTICE 100lm
-	-	A/R	49	01-026A752-30	SUB ASY, LR11 20 DEG WHITE 45lm JUSTICE
-	-	A/R	50	01-026A752-31	SUB ASY, LR11 20 DEG WHITE 100lm JUSTICE
A/R	A/R	A/R	51	01-026A752-10	SUB ASY, LR11 20 DEGREE AMBER JUSTICE
A/R	A/R	A/R	52	01-026A752-20	SUB ASY, LR11 20 DEGREE BLUE JUSTICE
A/R	A/R	A/R	53	01-026A752-50	SUB ASY, LR11 20 DEGREE RED JUSTICE
A/R	A/R	A/R	54	14-040285-063	SCREW, 4-40 X 3/8 TORX PH TRILOBULAR 410 SS, BLK
A/R	A/R	A/R	55	46-0921262-00	ASSY, "Y" 4" HARNESS ADVANTEDGE SERIES
A/R	A/R	A/R	56	68-1984949-10	DOME, AMB OPTIC END SHORT JUSTICE SERIES
A/R	A/R	A/R	57	68-1984949-13	DOME, AMB w/CLR ALLEY END SHORT JUSTICE
A/R	A/R	A/R	58	68-1984949-20	DOME, BLU OPTIC END SHORT JUSTICE SERIES
A/R	A/R	A/R	59	68-1984949-23	DOME, BLU, CLR ALLEY END SHORT JUSTICE
A/R	A/R	A/R	60	68-1984949-30	DOME, CLR OPTIC END SHORT JUSTICE SERIES
A/R	A/R	A/R	61	68-1984949-40	DOME, GRN OPTIC END SHORT JUSTICE SERIES
A/R	A/R	A/R	62	68-1984949-43	DOME, GRN, CLR ALLEY END SHORT JUSTICE
A/R	A/R	A/R	63	68-1984949-53	DOME, RED OPTIC END SHORT JUSTICE SERIES
A/R	A/R	A/R	64	68-1984949-53	DOME, RED, CLR ALLEY END SHORT JUSTICE
8	8	8	65	15-101416-288	SCREW, 10 X 1 3/4 PPHSMS 410 SS TYPE A, W/INSEAL
1	1	1	66	10-0322935-00	LABEL, "FRONT" LIGHTBAR ASSYS
1	1	1	67	10-0523364-00	LABEL, M/N S/N INSIDE ID JUSTICE SERIES
-	-	1	68	01-0483969007	KIT, 7 MOUNTING, RTTNL INSTALL
-	2	-	69	02-036A935-00	SUB ASSY, MAGNET MOUNT JUSTICE MINI
2	-	-	70	14-130436-120	SCREW, 1/4-20 X 3/4" HEX HD MS SS
2	-	-	71	16-1302820-06	WSHR, FLAT 1/4" 7/8 OD SS 17/64 ID .056-.070" THK
2	-	-	72	08-1583927-05	SUCTION CUP, MAGNET MOUNT
4	-	-	73	14-130526-08M	SCREW, 1/4-20 X 1/2" SET ALLEN SKT HD CUP PT
2	-	-	74	07-764726-023	PLATE, ADAPT. MAG/SUCTION CUP MINI LTBAR
-	2	-	75	10-0220700-02	LABEL, "NOT WARRANTEE... MOVING VEHICLE
2	-	-	76	10-0322406-02	LABEL, INFO/SUCTION CUP MT WARNING