

WHELEN[®]

ENGINEERING COMPANY INC.

51 Winthrop Road
 Chester, Connecticut 06412-0684
 Phone: (860) 526-9504
 Fax: (860) 526-2009
 Internet: www.whelen.com
 Sales/Service e-mail: aviation@whelen.com

Installation Guide:
Model 90520()-series
Model(s) 9052001, 9052051
P/N:01-0790520-01,
01-0790520-51
LED Flashing Split Anti-Collision
Light Assembly



TSO-C96a CLASS III
APPROVED



The conditions and tests required for TSO approval of this article are minimum performance standards. It is the responsibility of those installing this article either on or within a specific type or class of aircraft to determine that the aircraft installation conditions are within the TSO standards. TSO articles must have separate approval for installation in aircraft. The article may be installed only if performed under 14 CFR part 43 or the applicable airworthiness requirements.

OPERATING INSTRUCTIONS:

Operational Voltage: 28 VDC nominal
Average Input Current: 0.67 Amps
Pulse Input Current: 3.0 Amps @ .3 Seconds

The Model 90520 series LED Flashing Split Anti-collision Light Assembly meets the requirements of FAR 91.205(c)(3).

CONTINUED AIRWORTHINESS: The 90520 series LED Flashing Split Anti-collision Light Assembly is designed with 4 vertical columns consisting of 4 red LEDs each and 4 vertical columns consisting of 3 white LEDs each. Should any one LED or any vertical column fail, the unit must be repaired or replaced. Inspect the lens and replace if there is excessive scratching, discoloration or cracking.

INSTALLATION PROCEDURES: The following information is to assist in the installation of a Whelen LED Flashing Split Anti-collision Light System.

1. The installation procedure described in the following text will be confined to a single light installation, but is identical for multiple light installations.
2. Using the "suggested mounting hole pattern" prepare the aircraft for means to secure the LED Flashing Split Anti-collision Light Assembly. Remove any existing mounting adapters.
3. 28 VDC (+) and (-) ground leads equipped with an appropriate sized breaker to be supplied to the LED Flashing Split Anti-collision Light Assembly System. Both leads must be connected by an approved FAA connection. Insure that the wire leads are clear of any obstructions and ty-wrap as required.
4. Install the light assembly by first removing the lens. Remove the adapter plate. Attach the adapter plate to the aircraft mounting holes. Refer to page 2. Reinstall the light assembly and lens.
5. All inverted (bottom) mounted units shall require waterproofing of the flasher base assembly to the aircraft. **Note:** Drill a 1/8" hole in the center of the lens for bottom mount units.
6. Check all avionics systems for interference from this installation.
7. A flight check should be performed by a properly certified pilot.
8. Update aircraft records, complete Form 337 and obtain FAA field approval for installation, as required.

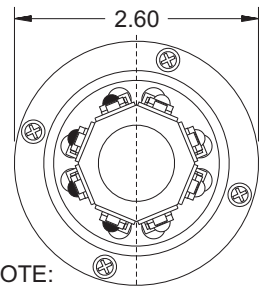

NOTE:
 RED LEDs
 TO THE FRONT

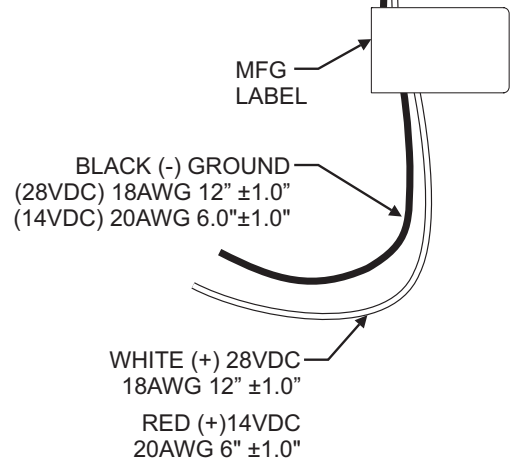
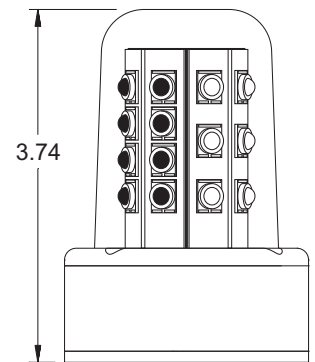

Aviation

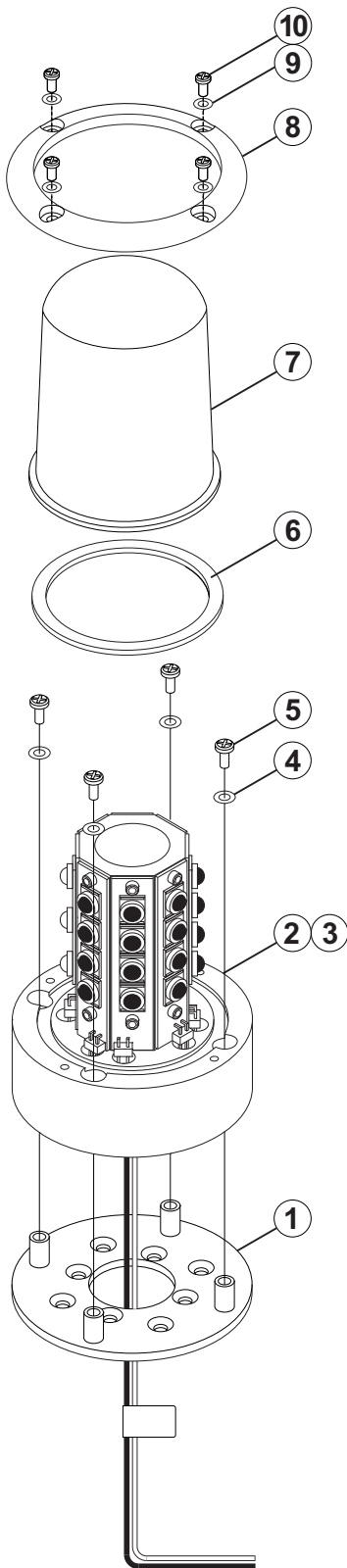

QTY	QTY	ITEM	PART NUMBER	DESCRIPTION
	*		01-0790520-01	MODEL 9052001 (IRIDITE / 28V)
	*		01-0790520-51	MODEL 9052051 (IRIDITE / 14V)
1	1	1	07-771051-100	ADAPTER PLATE, 8-HOLE
-	1	2	01-0290522-00	ASSY, 28V LED ANTI COLLISION LIGHT 90520
1	-	3	01-0290522-50	ASSY, 14V LED ANTI COLLISION LIGHT 90520
4	4	4	16-0050506136	WASHER, #6 LOCK-SPRING MS35338-136
4	4	5	14-0050503123	SCREW, 6-32 X 1/2 PPHMS SS MS51957-123
1	1	6	38-0250885-00	GASKET, LENS
1	1	7	68-4971082A30	LENS, CLEAR LED ANTI-COLLISION HARDCOAT
1	1	8	19-171047-100	RETAINER, LENS IRIDITE
4	4	9	16-0050506135	WASHER, #4 LOCK-SPRING MS35338-135
4	4	10	14-0050505-14	SCREW, 4-40 X 5/16 PPHMS MS51957-14

