

WHELEN[®]

ENGINEERING COMPANY INC.

51 Winthrop Road
 Chester, Connecticut 06412-0684
 Phone: (860) 526-9504
 Fax: (860) 526-2009
 Internet: www.whelen.com
 Sales/Service e-mail: aviation@whelen.com

Installation Guide: Model 71080()-series Model 7108051 P/N:01-0771080-51 LED Flashing Anti-Collision Light Assembly

TSO-C96a
 CLASS I, III;
 APPROVED



The conditions and tests required for TSO approval of this article are minimum performance standards. It is the responsibility of those installing this article either on or within a specific type or class of aircraft to determine that the aircraft installation conditions are within the TSO standards. TSO articles must have separate approval for installation in aircraft. The article may be installed only if performed under 14 CFR part 43 or the applicable airworthiness requirements.

OPERATING INSTRUCTIONS:

Operational Voltage: 14 VDC nominal
Average Input Current: 0.90 Amps
Peak Input Current: 4.0 @ .3 Seconds

The Model 71080 series LED anti-collision light assembly meets the requirements of FAR 91.205(c)(3).

EQUIPMENT LIMITATIONS: An approved anti-collision light assembly should be located so that the light will not impair the crew's vision or detract from the conspicuity of the position lights. The baseplate must be mounted parallel to the vertical and horizontal centerlines of the aircraft to project the patterns properly.

Certain types of installations may require additional testing.

CONTINUED AIRWORTHINESS: The 71080 series LED anti-collision light assembly is designed with 8 vertical columns consisting of 4 LEDs each. Should any one LED or any vertical column fail, the unit must be repaired or replaced. Inspect the lens and replace if there is excessive scratching, discoloration or cracking.

NOTE: To reduce eye strain, use an optical filter such as dark glasses or a blue covering dome during LED inspection.

INSTALLATION PROCEDURES: The following information is to assist in the installation of a Whelen LED Anti-collision Light System.

- Using the mounting detail information provided, prepare the aircraft for means to secure the light assembly.
- Carefully remove the #4 Phillips screw and lens retainer. Remove the lens.
CAUTION! Do not touch the LEDs with either fingers or sharp objects. This could soil and/or damage the LED and effect the optical performance of the LEDs. Remove the 4 Phillips head screws securing the adapter plate to the light assembly. Remove the adapter.
- Using the appropriate hardware, install the adapter plate to the aircraft.
- Route the wires through the opening in the adapter plate. Connect the light inputs according to the chart shown. Connect the power lead to an appropriately sized breaker. Connections to be in accordance with FAA approved methods.
- Reinstall the light assembly onto the adapter plate and insure that all leads are clear of any obstructions and secured as required.
- Install gasket, lens and lens retainer. Confirm proper gasket fit. Reinsert screws and tighten firmly.
- All inverted (bottom) mounted units shall require waterproofing of the base assembly to the aircraft. NOTE: Drill a 1/8" hole in the center of the lens for bottom mount units.
- Check all avionics systems for interference from this installation.
- A flight check should be performed by a properly certified pilot.
- Update aircraft records, complete Form 337 and obtain FAA field approval for installation as required.

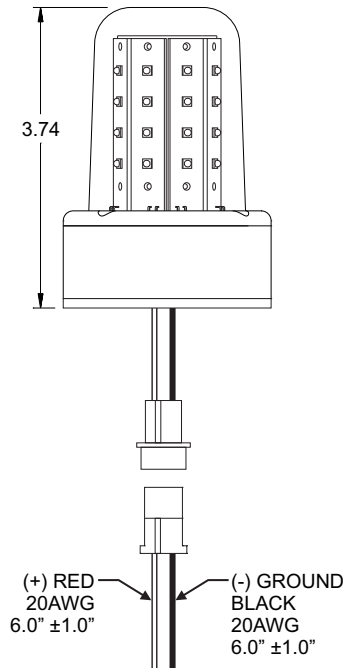
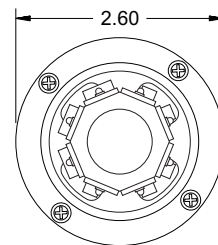

POS 1	(+) 14VDC	Red
POS 2	(-) GROUND	Black

Aviation

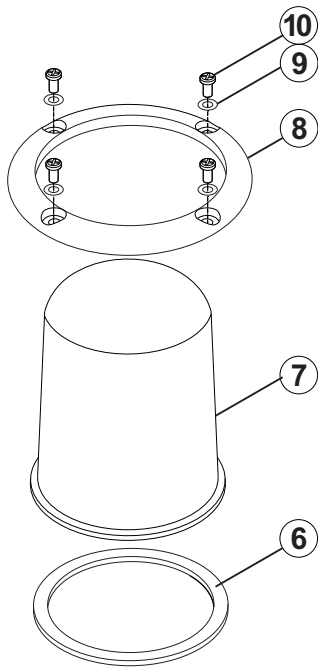

QTY	ITEM	PART NUMBER	DESCRIPTION
*		01-0771080-51	MODEL 7108051 (14V)
1	1	46-0750898-01	PIGTAIL, 14V ASSEMBLY
1	2	07-771051-100	ADAPTER PLATE, 8-HOLE
1	3	01-0271848-50	ASSY, 14V LED ANTI COLLISION LIGHT 71080
4	4	16-0050506136	WASHER, #6 LOCK-SPRING MS35338-136
4	5	14-0050503123	SCREW, 6-32 X 9/16 PPHMS SS MS51957-123
1	6	38-0250885-00	GASKET, LENS
1	7	68-4971082A30	LENS, CLEAR LED ANTI-COLLISION HARDCOAT
1	8	19-171047-100	RETAINER, LENS
4	9	16-0050506135	WASHER, #4 LOCK-SPRING MS35338-135
4	10	140050505-14	SCREW, 4-40 X 5/16 PPHMS MS51957-14

