

WHELEN[®] ENGINEERING COMPANY INC.

51 Winthrop Road,
Chester, Connecticut 06412-0684
Phone: (860) 526-9504
Fax: (860) 526-4078

Installation Guide: 400 Series to M4 Series Flange Adapter Model M4FC400

Internet: www.whelen.com
Sales e-mail: autosale@whelen.com
Canadian Sales e-mail: autocan@whelen.com
Customer Service e-mail: custserv@whelen.com

Installation:

1. Remove the existing 400 series lighthead and gasket from the mounting surface.
2. Mark the M4 flange mounting hole locations onto the mounting surface either by using the flange as a template or the measurements shown.
3. Drill four 1/4 inch mounting holes and insert the four supplied #8 round hole grommets.
4. Insert the two #8 square grommets into the flange and secure the lighthead to the flange with two #8 X 1" sheet metal screws.

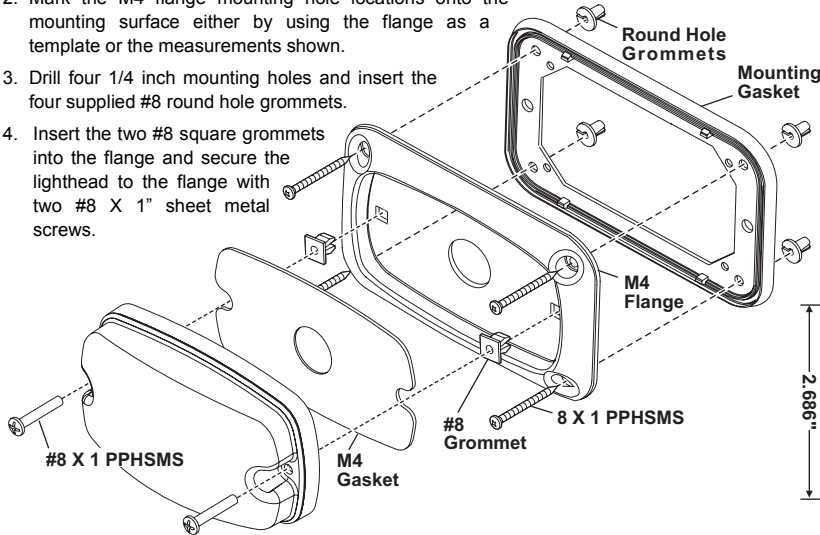

NOTE: Due to the mounting hole locations for the M Series and the variety of lighthead styles which may be replaced, cutting or drilling may be required for the screws going into the square grommets.

5. Secure the Flange and lighthead to the vehicle with the 4 supplied #8 X 1" sheet metal screws and round grommets you installed in step 3.
6. Extend the wires to your power source and connect as shown in the lighthead manual

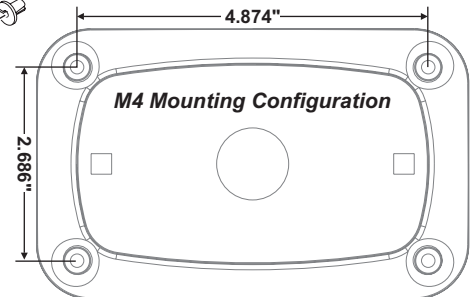

©2009 Whelen Engineering Company Inc.
Form No.14339 (080409)

For warranty information regarding this product, visit www.whelen.com/warranty

WHELEN[®] ENGINEERING COMPANY INC.

51 Winthrop Road,
Chester, Connecticut 06412-0684
Phone: (860) 526-9504
Fax: (860) 526-4078

Installation Guide: 400 Series to M4 Series Flange Adapter Model M4FC400

Internet: www.whelen.com
Sales e-mail: autosale@whelen.com
Canadian Sales e-mail: autocan@whelen.com
Customer Service e-mail: custserv@whelen.com

Installation:

1. Remove the existing 400 series lighthead and gasket from the mounting surface.
2. Mark the M4 flange mounting hole locations onto the mounting surface either by using the flange as a template or the measurements shown.
3. Drill four 1/4 inch mounting holes and insert the four supplied #8 round hole grommets.
4. Insert the two #8 square grommets into the flange and secure the lighthead to the flange with two #8 X 1" sheet metal screws.

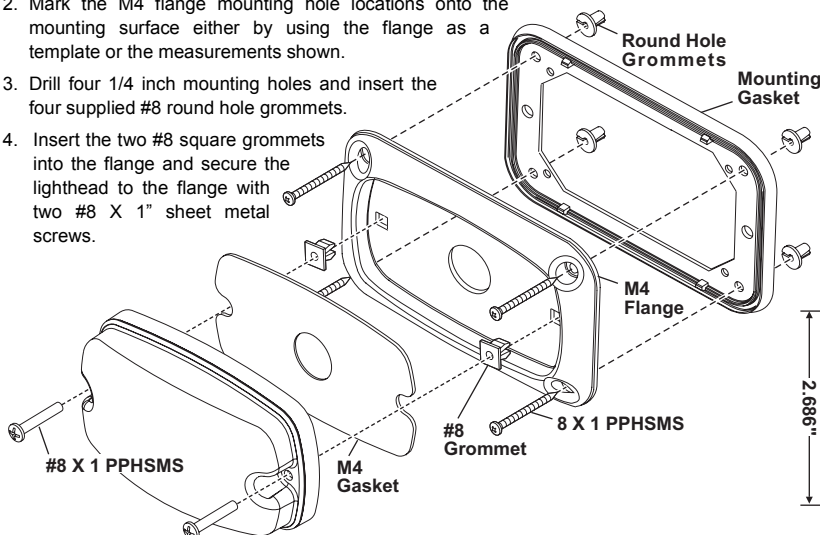

NOTE: Due to the mounting hole locations for the M Series and the variety of lighthead styles which may be replaced, cutting or drilling may be required for the screws going into the square grommets.

5. Secure the Flange and lighthead to the vehicle with the 4 supplied #8 X 1" sheet metal screws and round grommets you installed in step 3.
6. Extend the wires to your power source and connect as shown in the lighthead manual

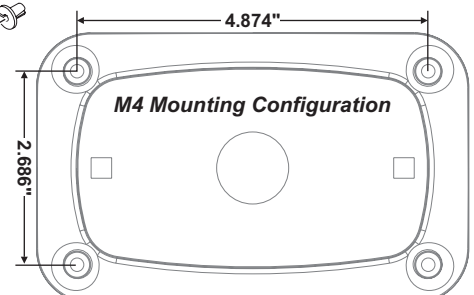

©2009 Whelen Engineering Company Inc.
Form No.14339 (080409)

For warranty information regarding this product, visit www.whelen.com/warranty