

WHELEN[®]

ENGINEERING COMPANY INC.

51 Winthrop Road,
Chester, Connecticut 06412-0684
Phone: (860) 526-9504
Fax: (860) 526-4078

Installation Guide: 400, 600 and 700 Series Lighthead Flange Kit Mounting

Internet: www.whelen.com
Sales e-mail: autosale@whelen.com
Canadian Sales e-mail: autocan@whelen.com
Customer Service e-mail: custserv@whelen.com

Installation:

Your flange comes with 2 gaskets. The die-cut gasket is installed inside the flange between the flange and the lighthead. The other gasket will install between the flange and the vehicle. It is very important to install both gaskets to prevent damage to both the lighthead and the vehicle.

IMPORTANT: If your flange kit includes one or more gaskets, they must be used in the installation. Failure to do so can result in vehicle corrosion and the eventual failure of the lighthead.



GASKETS SHOWN
INSTALLED ONTO
FLANGE

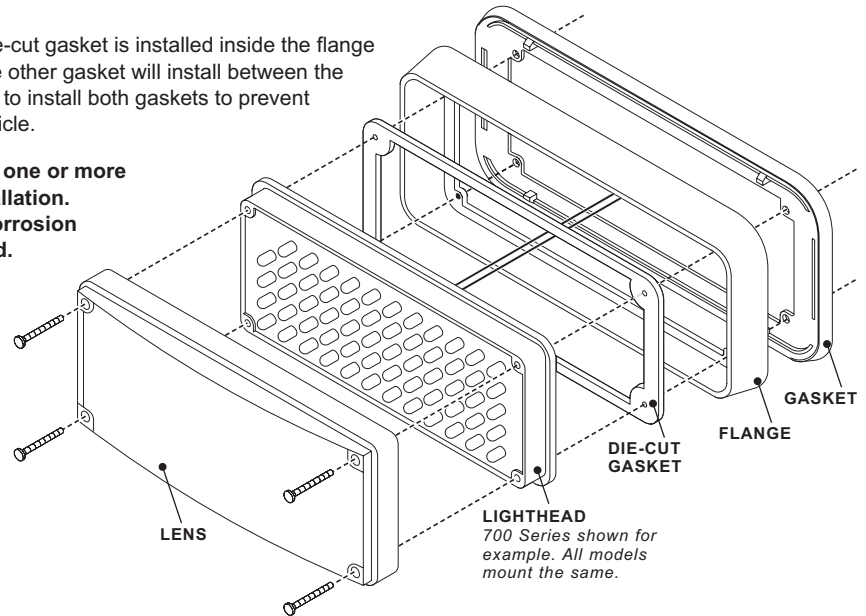

LIGHTHEAD
700 Series shown for
example. All models
mount the same.

©2010 Whelen Engineering Company Inc.
Form No.14386 (052710)

For warranty information regarding this product, visit www.whelen.com/warranty

WHELEN[®]

ENGINEERING COMPANY INC.

51 Winthrop Road,
Chester, Connecticut 06412-0684
Phone: (860) 526-9504
Fax: (860) 526-4078

Installation Guide: 400, 600 and 700 Series Lighthead Flange Kit Mounting

Internet: www.whelen.com
Sales e-mail: autosale@whelen.com
Canadian Sales e-mail: autocan@whelen.com
Customer Service e-mail: custserv@whelen.com

Installation:

Your flange comes with 2 gaskets. The die-cut gasket is installed inside the flange between the flange and the lighthead. The other gasket will install between the flange and the vehicle. It is very important to install both gaskets to prevent damage to both the lighthead and the vehicle.

IMPORTANT: If your flange kit includes one or more gaskets, they must be used in the installation. Failure to do so can result in vehicle corrosion and the eventual failure of the lighthead.



GASKETS SHOWN
INSTALLED ONTO
FLANGE

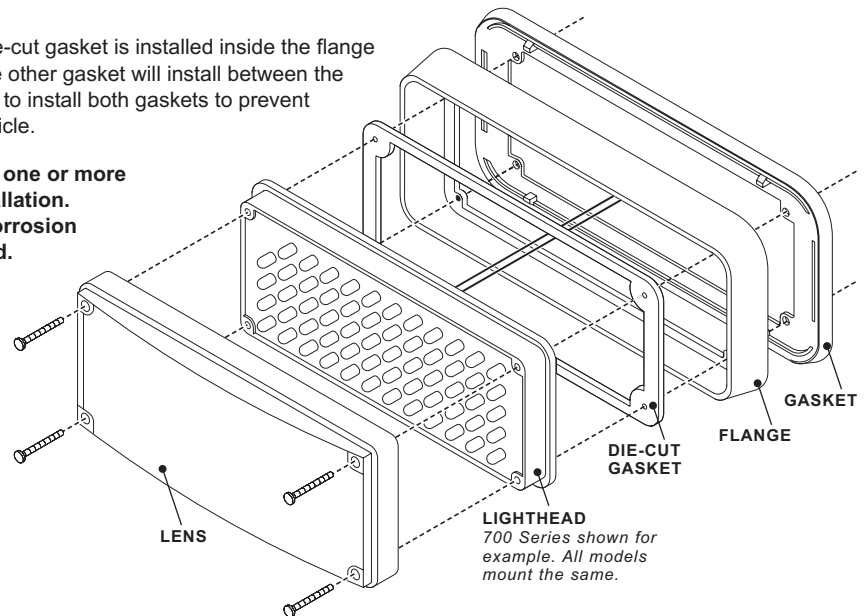

LIGHTHEAD
700 Series shown for
example. All models
mount the same.

©2010 Whelen Engineering Company Inc.
Form No.14386 (052710)

For warranty information regarding this product, visit www.whelen.com/warranty