

WHELEN[®]

ENGINEERING COMPANY INC.

51 Winthrop Road
Chester, Connecticut 06412-0684
Phone: (860) 526-9504
Fax: (860) 526-4078
Internet: www.whelen.com
Sales e-mail: autosale@whelen.com
Canadian Sales e-mail: canadiansales@whelen.com
Customer Service e-mail: custserv@whelen.com

Installation Guide:
PAR-32 LINZ6 Fog Light
2006 - 2013 Tahoe
Model: FECT10*R

Warnings to Installers

Whelen's emergency vehicle warning devices must be properly mounted and wired in order to be effective and safe. Read and follow all of Whelen's written instructions when installing or using this device. Emergency vehicles are often operated under high speed stressful conditions which must be accounted for when installing all emergency warning devices. Controls should be placed within convenient reach of the operator so that he can operate the system without taking his eyes off the roadway. Emergency warning devices can require high electrical voltages and/or currents. Properly protect and use caution around live electrical connections. Grounding or shorting of electrical connections can cause high current arcing, which can cause personal injury and/or vehicle damage, including fire. Many electronic devices used in emergency vehicles can create or be affected by electromagnetic interference. Therefore, after installation of any electronic device it is necessary to test all electronic equipment simultaneously to insure that they operate free of interference from other components within the vehicle. Never power emergency warning equipment from the same circuit or share the same grounding circuit with radio communication equipment. All devices should be mounted in accordance with the manufacturer's instructions and securely fastened to vehicle elements of sufficient strength to withstand the forces applied to the device. Driver and/or passenger air bags (SRS) will affect the way equipment should be mounted. This device should be mounted by permanent installation and within the zones specified by the vehicle manufacturer, if any. Any device mounted in the deployment area of an air bag will damage or reduce the effectiveness of the air bag and may damage or dislodge the device. Installer must be sure that this device, its mounting hardware and electrical supply wiring does not interfere with the air bag or the SRS wiring or sensors. Mounting the unit inside the vehicle by a method other than permanent installation is not recommended as unit may become dislodged during swerving; sudden braking or collision. Failure to follow instructions can result in personal injury. Whelen assumes no liability for any loss resulting from the use of this warning device. **PROPER INSTALLATION COMBINED WITH OPERATOR TRAINING IN THE PROPER USE OF EMERGENCY WARNING DEVICES IS ESSENTIAL TO INSURE THE SAFETY OF EMERGENCY PERSONNEL AND THE PUBLIC.**

Warnings to Users

Whelen's emergency vehicle warning devices are intended to alert other operators and pedestrians to the presence and operation of emergency vehicles and personnel. However, the use of this or any other Whelen emergency warning device does not guarantee that you will have the right-of-way or that other drivers and pedestrians will properly heed an emergency warning signal. Never assume you have the right-of-way. It is your responsibility to proceed safely before entering an intersection, driving against traffic, responding at a high rate of speed, or walking on or around traffic lanes. Emergency vehicle warning devices should be tested on a daily basis to ensure that they operate properly. When in actual use, the operator must ensure that both visual and audible warnings are not blocked by vehicle components (i.e.: open trunks or compartment doors), people, vehicles, or other obstructions. It is the user's responsibility to understand and obey all laws regarding emergency warning devices. The user should be familiar with all applicable laws and regulations prior to the use of any emergency vehicle warning device. Whelen's audible warning devices are designed to project sound in a forward direction away from the vehicle occupants. However, because sustained periodic exposure to loud sounds can cause hearing loss, all audible warning devices should be installed and operated in accordance with the standards established by the National Fire Protection Association.

Safety First

This document provides all the necessary information to allow your Whelen product to be properly and safely installed. Before beginning the installation and/or operation of your new product, the installation technician and operator must read this manual completely. Important information is contained herein that could prevent serious injury or damage.

- **Proper installation of this product requires the installer to have a good understanding of automotive electronics, systems and procedures.**
- **Whelen Engineering recommends the use of waterproof butt splices and/or connectors if that connector could be exposed to moisture.**
- **Failure to use specified installation parts and/or hardware will void the product warranty.**
- **If mounting this product requires drilling holes, the installer MUST be sure that no vehicle components or other vital parts could be damaged by the drilling process. Check both sides of the mounting surface before drilling begins. Also de-burr the holes and remove any metal shards or remnants. Install grommets into all wire passage holes.**
- **If this manual states that this product may be mounted with suction cups, magnets, tape or Velcro®, clean the mounting surface with a 50/50 mix of isopropyl alcohol and water and dry thoroughly.**
- **Do not install this product or route any wires in the deployment area of your air bag. Equipment mounted or located in the air bag deployment area will damage or reduce the effectiveness of the air bag, or become a projectile that could cause serious personal injury or death. Refer to your vehicle owner's manual for the air bag deployment area. The User/Installer assumes full responsibility to determine proper mounting location, based on providing ultimate safety to all passengers inside the vehicle.**
- **For this product to operate at optimum efficiency, a good electrical connection to chassis ground must be made. The recommended procedure requires the product ground wire to be connected directly to the NEGATIVE (-) battery post (this does not include products that use cigar power cords).**
- **If this product uses a remote device for activation or control, make sure that this device is located in an area that allows both the vehicle and the device to be operated safely in any driving condition.**
- **Do not attempt to activate or control this device in a hazardous driving situation.**
- **This product contains either strobe light(s), halogen light(s), high-intensity LEDs or a combination of these lights. Do not stare directly into these lights. Momentary blindness and/or eye damage could result.**
- **Use only soap and water to clean the outer lens. Use of other chemicals could result in premature lens cracking (crazing) and discoloration. Lenses in this condition have significantly reduced effectiveness and should be replaced immediately. Inspect and operate this product regularly to confirm its proper operation and mounting condition. Do not use a pressure washer to clean this product.**
- **It is recommended that these instructions be stored in a safe place and referred to when performing maintenance and/or reinstallation of this product.**
- **FAILURE TO FOLLOW THESE SAFETY PRECAUTIONS AND INSTRUCTIONS COULD RESULT IN DAMAGE TO THE PRODUCT OR VEHICLE AND/OR SERIOUS INJURY TO YOU AND YOUR PASSENGERS!**

Installation:

1. This installation can be done by going under the front bumper to access the fog lights. If you have difficulty gaining access to the fog lights you may have to remove fasteners toward the front of the wheel well that hold the wheel shroud on and peel the shroud back (Refer to vehicle tech manual).

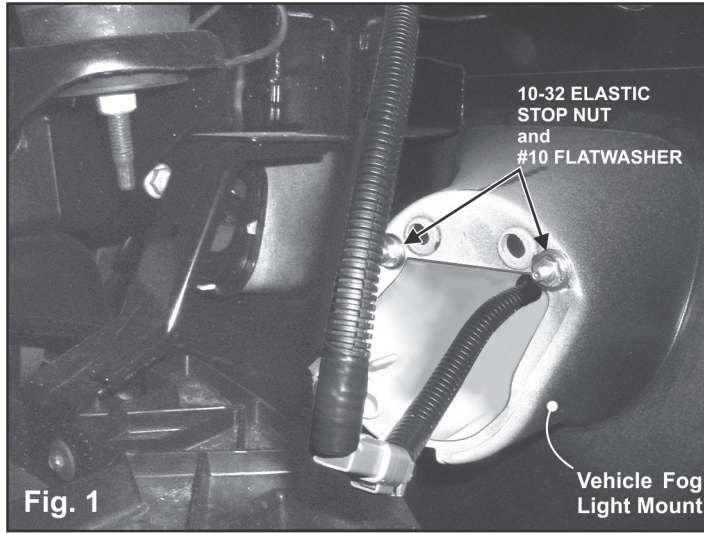

2. Unplug the existing fog light from the wiring harness, remove the mounting hardware and remove the fog light from the vehicle. If the vehicle is not equipped with fog lights remove the rubber plug from this location. The plug is removed by pinching together the retaining clips protruding from the back to disengage the plug allowing it to be pushed out towards the front of the vehicle.
3. Insert the LED fog light into the hole the parking light occupied. **NOTE: Be sure the lighthouse is oriented so that the word "TOP" is located at the top of the lighthouse.**
4. Mount the LED fog light into the 2 slots the existing fog light mounted to (Fig. 1). Secure the fog light using the supplied mounting hardware.
5. Connect the wires to the fog light wiring and replace any fasteners or screws you removed in step 1.

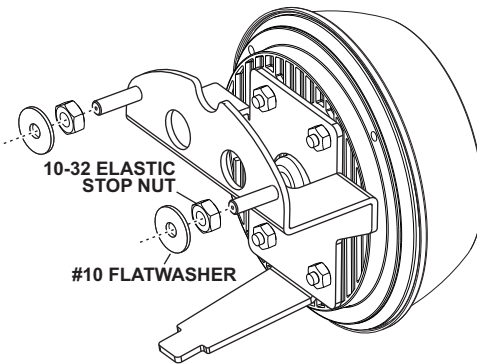

Connect the wires to the existing fog light wiring. LED wire designations:
 RED-WHT, WHT-RED, YEL, ORG, BLU, WHT, GRN or RED+VBAT
 BLK Ground (-)
 WHT/VIO Scan-Lock™
 GREY SYNC / Must connect to other SYNC wires to run SYNC feature

Operation: The LED fog light features Scan-Lock™ flash pattern selection and SYNChronization capabilities. These two functions will operate as follows:

Scan-Lock™ (White/Violet):

TO CHANGE PATTERNS: To cycle forward to the next available pattern, apply +VBAT to the WHT/VIO wire for less than 1 second and release. To cycle back to the previous pattern, apply +VBAT to the WHT/VIO wire for more than 1 second and release.

TO CHANGE THE DEFAULT PATTERN: When the desired pattern is displayed, allow it to run for more than 5 seconds. The lighthouse will now display this pattern when initially activated.

TO RESTORE THE FACTORY DEFAULT PATTERN: With the power to the lighthouse off, apply +VBAT to the WHT/VIO wire. With the WHT/VIO wire still activated, turn power to the lighthouse on. The factory default pattern should now be displayed.

Use a normally open momentary switch to control Scan-Lock™.

SYNC (Grey):

SYNC lighthouses have a special set of flash patterns, with each pattern available in two modes; Phase 1 and Phase 2. All lighthouses configured to display the Phase 1 mode of a given pattern will flash simultaneously. Any lighthouses configured to display the Phase 2 mode of a pattern, will alternate with any Phase 1 lighthouses of the same pattern.

To sync two flashing LED fog lights, configure both lights to display the same Phase 1 pattern. With the power off, connect the GRY wires from each lighthouse together. When the lighthouses are activated, their patterns will be synchronized. To configure the two lighthouses to alternate their patterns, advance the pattern of either lighthouse to the Phase 2 mode of the current pattern.

Available Patterns:

1. SignalAlert™ 75Phase 1	9. ComAlert™ 75...Phase 1	18.SingleFlash 300
2. SignalAlert™ 75Phase 2	10.ComAlert™ 75..Phase 2	19.DoubleFlash 150
3. CometFlash® 75Phase 1	11.LongBurst™ 75 .Phase 1	20.ComAlert™ 150
4. CometFlash® 75Phase 2	12.LongBurst™ 75 Phase 2	21.ActionFlash™ 50
5. DoubleFlash 75 Phase 1	13.PingPong™ 75..Phase 1	22.ActionFlash™ 150
6. DoubleFlash 75 Phase 2	14.PingPong™ 75 .Phase 2	23.ModuFlash™
7. SingleFlash 75 . Phase 1	15.SingleFlash 60	24.ActionScan™
8. SingleFlash 75 . Phase 2	16.SingleFlash 90	25.Steady
	17.SingleFlash 120	

WARNING! All customer supplied wires that connect to the positive terminal of the battery must be sized to supply at least 125% of the maximum operating current and FUSED at the battery to carry that load. DO NOT USE CIRCUIT BREAKERS WITH THIS PRODUCT!

WARNING!It is the responsibility of the installation technician to make sure that the installation and operation of this product will not interfere with or compromise the operation or efficiency of any vehicle equipment!

IMPORTANT! Before returning the vehicle to active service, visually confirm the proper operation of this product, as well as all vehicle components/ equipment.

IMPORTANT WARNING!
CAUTION! DO NOT LOOK DIRECTLY AT THESE LED'S WHILE THEY ARE ON. MOMENTARY BLINDNESS AND/OR EYE DAMAGE COULD RESULT!