

WHELEN[®]

ENGINEERING COMPANY INC.

51 Winthrop Road
Chester, Connecticut 06412-0684
Phone: (860) 526-9504
Fax: (860) 526-4078
Internet: www.whelen.com
Sales e-mail: autosale@whelen.com
Canadian Sales e-mail: canadiansales@whelen.com
Customer Service e-mail: custserv@whelen.com

Installation Guide: Dominator™ LINZ6™ Lightbar (Single)

Safety First

This document provides all the necessary information to allow your Whelen product to be properly and safely installed. Before beginning the installation and/or operation of your new product, the installation technician and operator must read this manual completely. Important information is contained herein that could prevent serious injury or damage.

- Proper installation of this product requires the installer to have a good understanding of automotive electronics, systems and procedures.
- If mounting this product requires drilling holes, the installer **MUST** be sure that no vehicle components or other vital parts could be damaged by the drilling process. Check both sides of the mounting surface before drilling begins. Also de-burr any holes and remove any metal shards or remnants. Install grommets into all wire passage holes.
- If this manual states that this product may be mounted with suction cups, magnets, tape or Velcro®, clean the mounting surface with a 50/50 mix of isopropyl alcohol and water and dry thoroughly.
- Do not install this product or route any wires in the deployment area of your air bag. Equipment mounted or located in the air bag deployment area will damage or reduce the effectiveness of the air bag, or become a projectile that could cause serious personal injury or death. Refer to your vehicle owner's manual for the air bag deployment area. The User/Installer assumes full responsibility to determine proper mounting location, based on providing ultimate safety to all passengers inside the vehicle.
- For this product to operate at optimum efficiency, a good electrical connection to chassis ground must be made. The recommended procedure requires the product ground wire to be connected directly to the **NEGATIVE (-)** battery post.
- If this product uses a remote device to activate or control this product, make sure that this control is located in an area that allows both the vehicle and the control to be operated safely in any driving condition.
- Do not attempt to activate or control this device in a hazardous driving situation.
- This product contains either strobe light(s), halogen light(s), high-intensity LEDs or a combination of these lights. Do not stare directly into these lights. Momentary blindness and/or eye damage could result.
- Use only soap and water to clean the outer lens. Use of other chemicals could result in premature lens cracking (crazing) and discoloration. Lenses in this condition have significantly reduced effectiveness and should be replaced immediately. Inspect and operate this product regularly to confirm its proper operation and mounting condition. Do not use a pressure washer to clean this product.
- It is recommended that these instructions be stored in a safe place and referred to when performing maintenance and/or reinstallation of this product.
- **FAILURE TO FOLLOW THESE SAFETY PRECAUTIONS AND INSTRUCTIONS COULD RESULT IN DAMAGE TO THE PRODUCT OR VEHICLE AND/OR SERIOUS INJURY TO YOU AND YOUR PASSENGERS!**

For warranty information regarding this product, visit www.whelen.com/warranty

Specifications:

| | |
|--------------------------|----------------------------|
| Input Voltage: | 12.8 VDC +/- 20% |
| Input Current: | Peak - 750ma / Avg - 300ma |
| Sync: | Active Low |
| Input Scan-Lock™: | +12 VDC |

Installation:

Note: When routing the wires, it is very important that you choose a path that will keep the wires away from excessive heat or any vehicle equipment that could compromise the integrity of the wires (ex. trunk lids, door jams, etc.).

End view of extrusion with endcap removed.

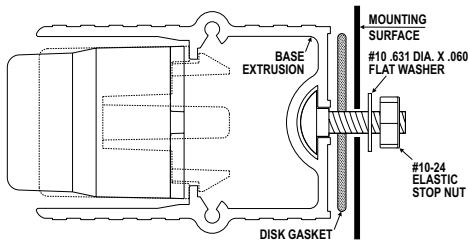

IMPORTANT! The lightbar should be located a minimum of 16" from any radio antennas!

1. Position the unit in its proposed mounting location. Draw a pencil line onto the mounting surface along the top and bottom of the extrusion and a "centerline" centered between the two.
2. Two 1/4" holes are required to mount this unit. These holes may be located anywhere along the horizontal centerline that you drew in step one. It's best to locate the holes as far apart as possible. Mark the hole location onto the mounting surface.
3. Using a 1/4" drill bit, drill a hole in each of the areas scribed in the previous step.
4. Slide the 2 carriage bolts (installed in the rear of the bar) over to the 2 mounting holes, install the rubber gaskets onto the bolts then insert them into the mounting holes.
5. Secure the unit by threading the flat washer and elastic stop nut onto each bolt and tightening them firmly.

Wiring: Refer to the wiring diagram on the next page.

WARNING: All customer supplied wires that connect to the positive terminal of the battery must be sized to supply at least 125% of the maximum operating current and **FUSED** at the battery to carry that load. **DO NOT USE CIRCUIT BREAKERS WITH THIS PRODUCT!**

Scan-Lock™ (White)

LINZ6™ lightheads have flash patterns that are available in two modes; Phase 1 and Phase 2. The patterns are changed with the WHITE wire. With the lightbar powered up:

To advance to the next pattern, apply +12 VDC to the WHITE wire for less than 1 second. To cycle backwards to previous patterns, apply +12 VDC for more than 1 second.

To reset to the factory default pattern, begin by turning off power to the lightbar. While applying +12 VDC to the WHITE wire, turn the lightbar back on. Continue to apply voltage to the WHITE wire for 5 seconds.

All lights configured to display the Phase 1 mode of a given pattern will flash simultaneously. Any lights configured to display the Phase 2 mode of a pattern will alternate with any Phase 1 lights with the same pattern.

Sync (Green)

To sync two lightbars, configure both lightbars to display the same Phase 1 pattern. With the power off, connect the GREEN wire from each lightbar together. When the lightbars are activated, their patterns will be synchronized. To configure the two lightbars to alternate their patterns, advance the pattern of either lightbar to the Phase 2 mode of the current pattern.

EXAMPLE:

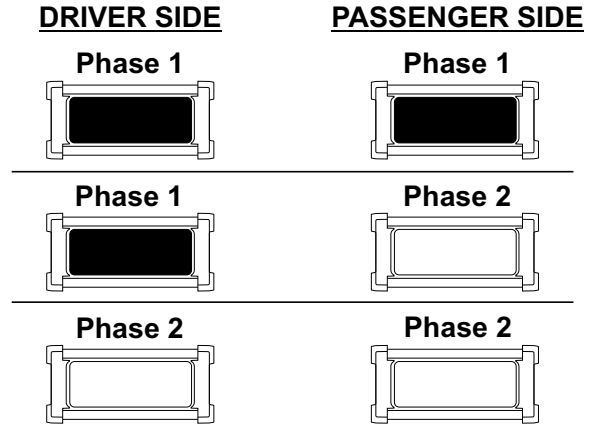

To understand how to use the SYNC feature with more than 2 lights, the principles will be applied to a sample system consisting of 4 lights. Two are mounted on the rear, driver side of the vehicle and two are mounted on the rear, passenger side of the vehicle.

With all the wiring complete, turn on the 4 lights. As shipped from the factory, all the lights will simultaneously display the same pattern (Signal Alert™ 75 Phase 1).

To configure, for example, the passenger side lights to alternate with the driver side lights, change the flash patterns for either the passenger or driver side lights to Phase 2 of the same pattern.

Available Flash Patterns (* = California Title XIII compliant)

SYNC Flash Patterns:

- | | |
|----------------------------|----------------------------|
| 1. SignalAlert™ 75 Phase 1 | 8. SingleFlash 75 Phase 2* |
| 2. SignalAlert 75 Phase 2 | 9. ComAlert™ 75 Phase 1 |
| 3. CometFlash® 75 Phase 1 | 10. ComAlert 75 Phase 2 |
| 4. CometFlash 75 Phase 2 | 11. LongBurst™ 75 Phase 1 |
| 5. DoubleFlash 75 Phase 1 | 12. LongBurst 75 Phase 2 |
| 6. DoubleFlash 75 Phase 2 | 13. PingPong™ 75 Phase 1 |
| 7. SingleFlash 75 Phase 1 | 14. PingPong 75 Phase 2 |

Regular Flash Patterns:

- | | |
|---------------------|---------------------|
| 1. SingleFlash 60* | 7. ActionFlash™ 50 |
| 2. SingleFlash 90* | 8. ActionFlash™ 150 |
| 3. SingleFlash 120* | 9. ModuFlash™ |
| 4. SingleFlash 300 | 10. ActionScan™ |
| 5. DoubleFlash 150 | 11. Steady |
| 6. ComAlert™ 150 | |

IMPORTANT WARNING!

CAUTION! DO NOT LOOK DIRECTLY AT THESE LED'S WHILE THEY ARE ON. MOMENTARY BLINDNESS AND/OR EYE DAMAGE COULD RESULT!

IMPORTANT! Before returning this vehicle to active service, visually confirm the proper operation of this product, as well as all vehicle components/equipment.

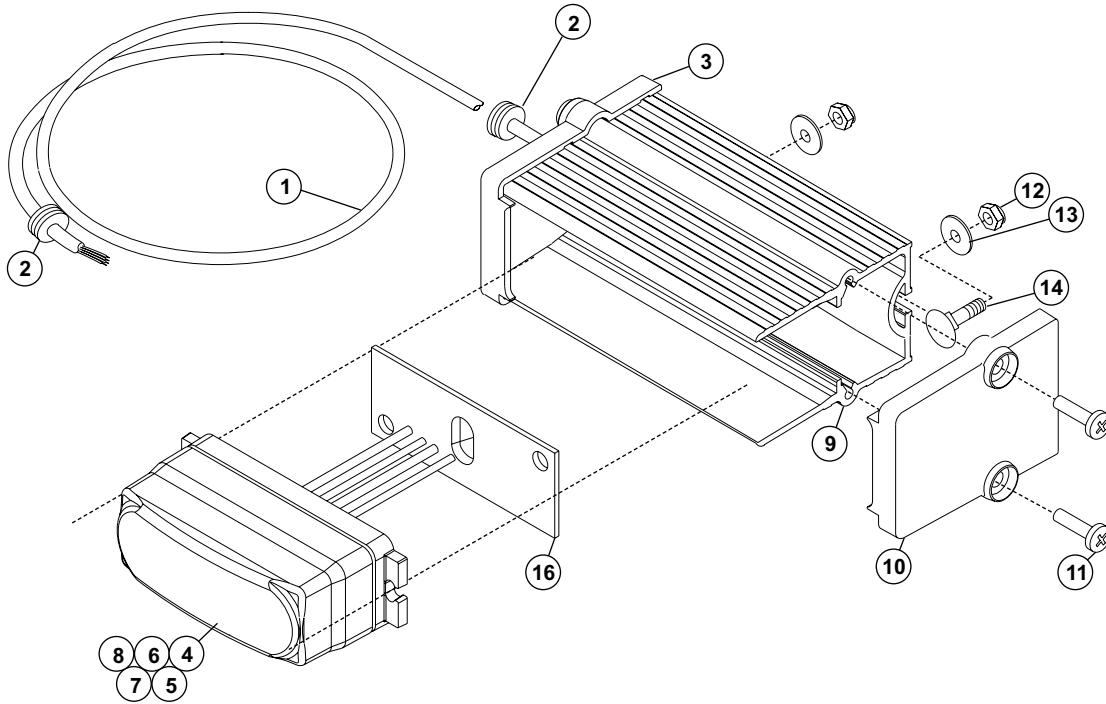
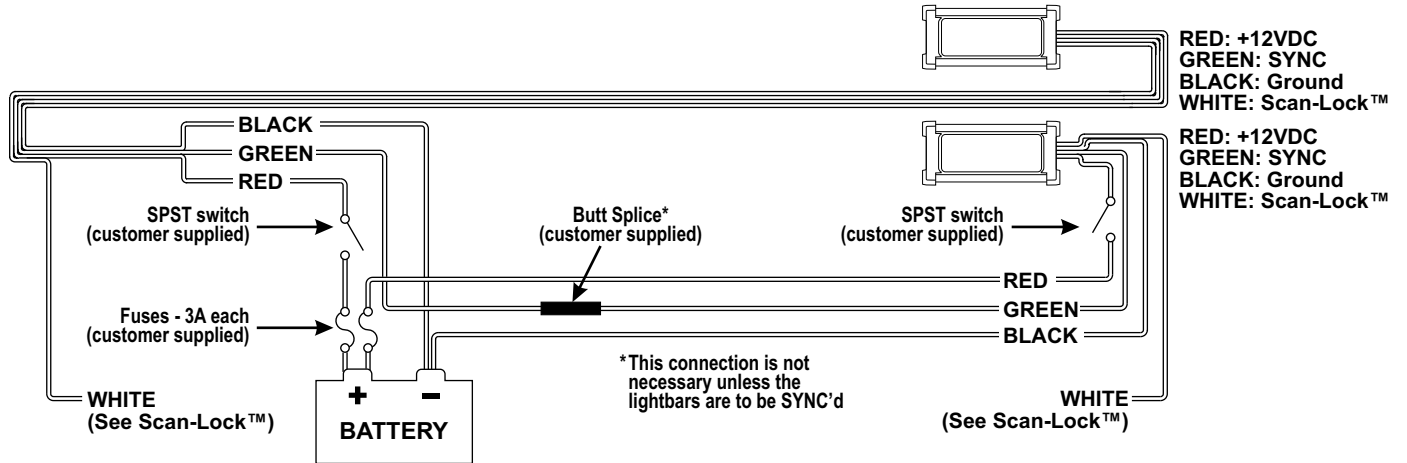

| QTY | ITEM | PART NUMBER | DESCRIPTION |
|-----|------|---------------|--------------------------------------|
| * | | 01-0686302-_0 | LIGHT ASSY, DOM PLUS W/SINGLE LINZ 6 |
| 1 | 1 | 46-0743146-09 | 4/C 18 GA 20' STRIP BOTH ENDS 2" |
| 2 | 2 | 21-11091202-0 | GROMMET, 3/8" #905 |
| 1 | 3 | 11-263726-002 | ENDCAP, (3)TIR EXTR. MT. W/ HOLE |
| A/R | 4 | 01-026B042410 | ASSY, ELECT LINZ6 AMBER SYNC |
| A/R | 5 | 01-026B042420 | ASSY, ELECT LINZ6 BLUE SYNC |
| A/R | 6 | 01-026B042430 | ASSY, ELECT LINZ6 WHITE SYNC |
| A/R | 7 | 01-026B042440 | ASSY, ELECT LINZ6 GREEN SYNC |
| A/R | 8 | 01-026B042450 | ASSY, ELECT LINZ6 RED SYNC |
| 1 | 9 | 11-443031-003 | EXTRUSION, MACH'D - 3.21 |
| 1 | 10 | 11-263726-000 | ENDCAP, (3)TIR EXTR. MT. W/O HOLE |
| 4 | 11 | 14-062219-06D | SCREW, #6-32 X 3/8 PPHMS ROLOK ZN |
| 1 | 12 | 10-0523506-__ | LABEL |
| 2 | 13 | 13-104320-120 | NUT, #10-24 ACORN SS |
| 2 | 14 | 16-1002220-50 | WASHER, #10 FLAT .631 DIA. X .060 |
| 2 | 15 | 14-104066-080 | CARRIAGE BOLT, #10-24 X 1/2 LG SS |
| 4 | 16 | 25-0022214-01 | BUTT SPLICE, 22-18 RED WATERPROOF |
| 1 | 17 | 38-0123288-00 | GASKET, EXTRUSION MOUNT |

01-0686302-_0

LED COLOR

- 1 - AMBER
- 2 - BLUE
- 3 - WHITE
- 4 - GREEN
- 5 - RED