

WHELEN[®]

ENGINEERING COMPANY INC.

51 Winthrop Road
Chester, Connecticut 06412-0684
Phone: (860) 526-9504
Fax: (860) 526-4078
Internet: www.whelen.com
Sales e-mail: autosale@whelen.com
Canadian Sales e-mail: canadiansales@whelen.com
Customer Service e-mail: custserv@whelen.com

Installation Guide: Liberty™ WeCan® Tri-Color Lightbar

Safety First

This document provides all the necessary information to allow your Whelen product to be properly and safely installed. Before beginning the installation and/or operation of your new product, the installation technician and operator must read this manual completely. Important information is contained herein that could prevent serious injury or damage.

- Proper installation of this product requires the installer to have a good understanding of automotive electronics, systems and procedures.
- If mounting this product requires drilling holes, the installer **MUST** be sure that no vehicle components or other vital parts could be damaged by the drilling process. Check both sides of the mounting surface before drilling begins. Also de-burr any holes and remove any metal shards or remnants. Install grommets into all wire passage holes.
- If this manual states that this product may be mounted with suction cups, magnets, tape or Velcro®, clean the mounting surface with a 50/50 mix of isopropyl alcohol and water and dry thoroughly.
- Do not install this product or route any wires in the deployment area of your air bag. Equipment mounted or located in the air bag deployment area will damage or reduce the effectiveness of the air bag, or become a projectile that could cause serious personal injury or death. Refer to your vehicle owner's manual for the air bag deployment area. The User/Installer assumes full responsibility to determine proper mounting location, based on providing ultimate safety to all passengers inside the vehicle.
- For this product to operate at optimum efficiency, a good electrical connection to chassis ground must be made. The recommended procedure requires the product ground wire to be connected directly to the **NEGATIVE (-)** battery post.
- If this product uses a remote device to activate or control this product, make sure that this control is located in an area that allows both the vehicle and the control to be operated safely in any driving condition.
- Do not attempt to activate or control this device in a hazardous driving situation.
- This product contains either strobe light(s), halogen light(s), high-intensity LEDs or a combination of these lights. Do not stare directly into these lights. Momentary blindness and/or eye damage could result.
- Use only soap and water to clean the outer lens. Use of other chemicals could result in premature lens cracking (crazing) and discoloration. Lenses in this condition have significantly reduced effectiveness and should be replaced immediately. Inspect and operate this product regularly to confirm its proper operation and mounting condition. Do not use a pressure washer to clean this product.
- It is recommended that these instructions be stored in a safe place and referred to when performing maintenance and/or reinstallation of this product.
- **FAILURE TO FOLLOW THESE SAFETY PRECAUTIONS AND INSTRUCTIONS COULD RESULT IN DAMAGE TO THE PRODUCT OR VEHICLE AND/OR SERIOUS INJURY TO YOU AND YOUR PASSENGERS!**

For warranty information regarding this product, visit www.whelen.com/warranty

IMPORTANT! The lightbar should be a minimum of 16" from any radio antennas!

Permanent Mounting:

1. Locate the mounting foot and locking plate included with your lightbar. If not already present, install the locking plate onto the mounting foot using the supplied allen screws. **MKAJ: On the adjustable mounting foot, you must first drill the hole in the foot, that is mentioned here in step 6. Use the hole in the mounting pad as a guide.**
2. Flip the lightbar upside-down to expose the bottom of the extrusion and place the mounting foot onto the extrusion.

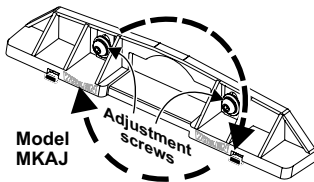
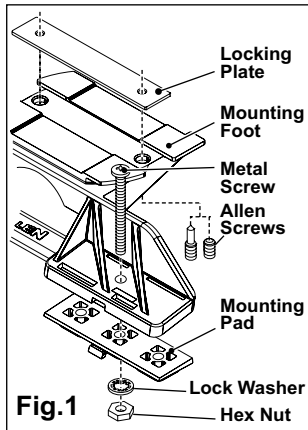

3. Rotate the mounting foot 90° counter-clockwise. Make sure that the edges of the foot slide under the extrusion mounting lip (See illustrations A & B). Repeat this procedure for the remaining mounting foot and return the lightbar to its right side-up position.
4. Position the lightbar onto the vehicle roof in the desired mounting location. One often selected location is directly above the B-pillars. This area is the strongest part of the roof. Refer to your lightbar manual for cable exit location, to be sure that the lightbar is facing the proper direction.
5. Adjust the two feet outwards so that they are as close to the edge of the roof as possible (See below). Make sure that both mounting feet are in full contact with the roof and that there is no less than 1/2" clearance between roof and lightbar. When the mounting feet are in position, carefully tighten the locking plate allen head set screws.
6. With the lightbar in its exact mounting position, use the hole in the mounting foot as a guide and mark the mounting hole location off onto the mounting surface.
7. Remove the lightbar and drill the mounting holes you marked off in step 6.
8. Place the lightbar back onto the vehicle lined up with the mounting holes and secure it to the vehicle using the supplied hardware.

NOTE: Model MKAJ is an adjustable mounting foot. On this model you may loosen the screws on the rear of the foot and adjust the angle of the lightbar. This feature can be used if the angle of the roof is not level with the road.

IMPORTANT: To adjust the leveling screws, use a torque wrench set at 35 to 40 in./lbs.

NOTE: Unless otherwise specified, the lightbar mounting feet must be sitting as close to the edge of the roof as possible. Mounting feet must be in full contact with the roof and not be hanging off the edge.

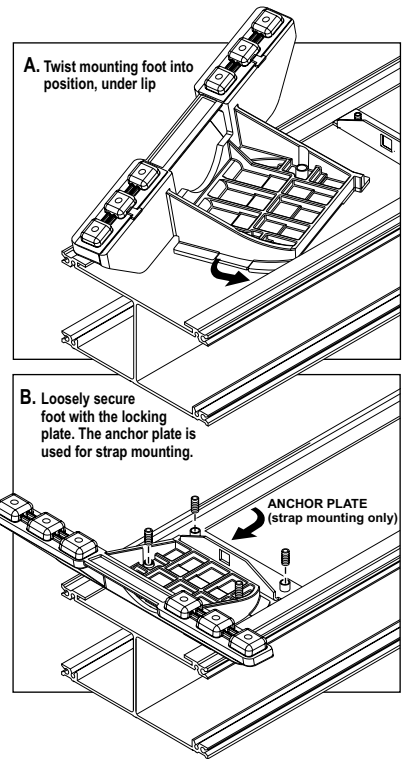
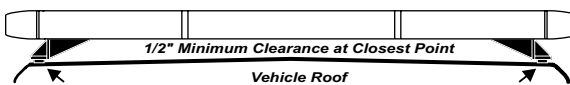

Strap Mounting:

1. Locate the mounting foot, anchor plate and locking plate included with your lightbar. If not already present, install the locking plate onto the mounting foot using the supplied allen set screws.
2. Flip the lightbar upside-down to expose the bottom of the extrusion and place the mounting foot onto the extrusion (See illustrations A & B above).
3. Rotate the foot 90° counter-clockwise. Make sure that the edges of the foot slide under the extrusion mounting lip. Install an anchor plate onto the extrusion in the same manner.
4. Repeat this procedure for the remaining mounting foot and anchor plate and return the lightbar to its right side-up position.
5. Position the lightbar onto the vehicle roof in the desired mounting location. One often selected location is directly above the B-pillars. This area is the strongest part of the roof. Refer to your lightbar manual for cable exit location, to be sure that the lightbar is facing the proper direction.
6. Adjust the two mounting feet outwards so that they are as close to the edge of the roof as possible. Both mounting feet must be in full contact with the roof. Be sure that there is no less than 1/2" clearance between roof and lightbar (See above). When the mounting feet are in position, carefully tighten the locking plate allen set screws.
7. Return the lightbar to an upside-down position. Slide each anchor plate outwards until it is fully engaged with its corresponding mounting foot. With the mounting feet and anchor plates in position, firmly tighten all of the allen set screws (2 or 4 per side). Flip the lightbar over and return it to its mounting position.
8. Open both drivers side doors. In the area directly below the mounting foot, pull the weather-strip away from the vehicle so the area where the mounting strap will be secured is exposed. Repeat for the other side.
9. Insert the mounting strap through the mounting foot. Be sure that the strap fits flush against the area where it will be secured onto the vehicle. Insert the tension bolt through the mounting strap and anchor plate, into the tinnerman nut. Tighten slightly with a long-shafted, Phillips screwdriver. Repeat procedure for passenger side.
10. If your mounting strap has mounting holes on the end of the strap, use these holes as a template to drill appropriately sized pilot holes through the strap and into the vehicle. Secure the strap to the vehicle with the supplied mounting screws. Repeat steps 8 - 10 for the passenger side of the vehicle.
11. Firmly tighten the tension bolts to secure lightbar to vehicle.

Standard Foot Model MKEZ

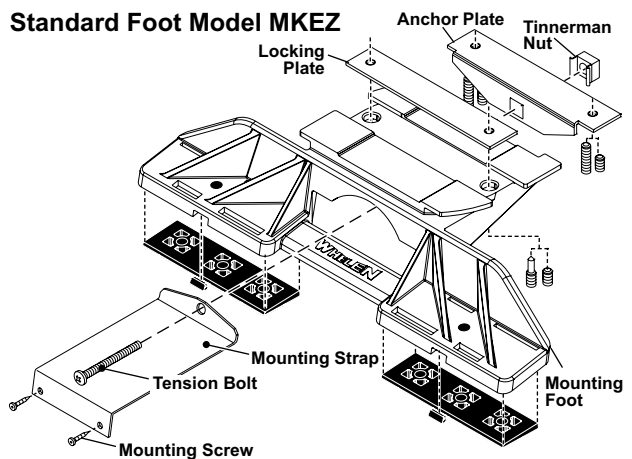

Adjustable Foot Model MKAJ

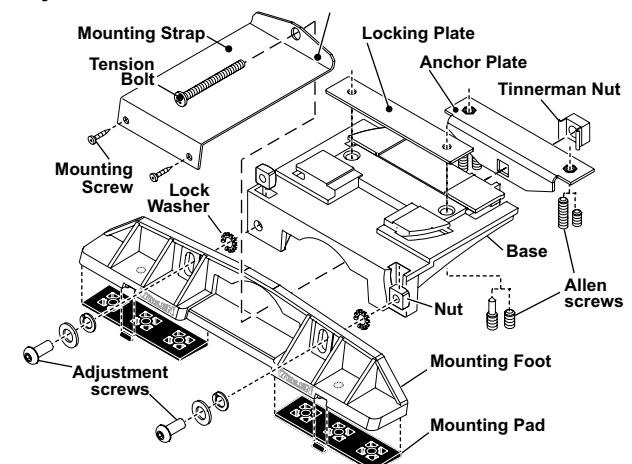

5" Mounting Foot

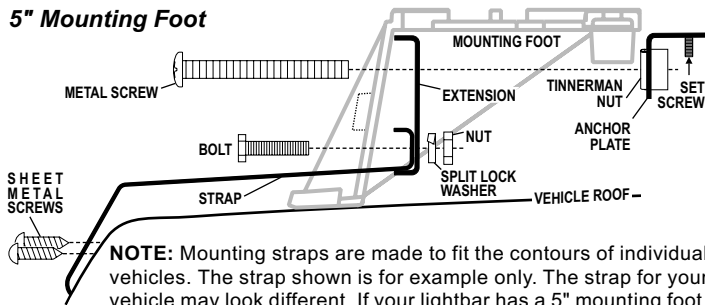

NOTE: Mounting straps are made to fit the contours of individual vehicles. The strap shown is for example only. The strap for your vehicle may look different. If your lightbar has a 5" mounting foot, it will assemble differently than the standard mounting foot. It also uses an extension to compensate for the extra height. Follow this illustrations for assembly. Mounting to the lightbar is the same.

Routing the Lightbar Cable(s):

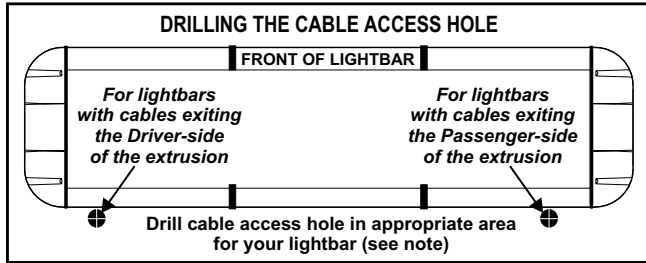

- To protect the headliner from damage caused by drilling the cable access hole through the vehicle roof, allow a 5" to 7" distance between roof and headliner by lowering the headliner before drilling.
- Using a 1" hole saw, drill the cable access hole then use a round file to smooth and de-burr the edges of the hole. Install a 1" grommet (user supplied).

NOTE: There may be a roof support member that spans the distance between the driver's and passenger's side. **DO NOT DRILL THROUGH THIS MEMBER!** Adjust the location until the hole can be drilled without contacting this support member.

- Insert the cable(s) through the cable access hole into the vehicle. Use RTV silicone to weatherproof the access hole after the cable(s) are pulled completely into the vehicle.
- Route the cable(s) one at a time to their respective destinations (power cable to vehicle battery; control cable to switch panel). Refer to the instructions included with your switches for switch wiring information.

IMPORTANT AIR BAG WARNING! Do not install this product or route any wires in the air bag deployment zone of your vehicle. Equipment mounted or located in air bag deployment zones will damage or reduce the effectiveness of the air bag, or become a projectile that could cause serious personal injury or death. Refer to your vehicle owners manual to learn the air bag deployment zones for the vehicle. The User/Installer assumes full responsibility to determine proper mounting location, based on providing ultimate safety to all passengers inside the vehicle.

Connecting the Power Cable:

WARNING! All customer supplied wires that connect to the positive terminal of the battery must be sized to supply at least 125% of the maximum operating current and **FUSED** at the battery to carry that load. **DO NOT USE CIRCUIT BREAKERS WITH THIS PRODUCT!**

- Follow the factory wiring harness through the firewall. It may be necessary to drill a hole in the firewall. If so, be absolutely sure that there are no components that could be damaged by drilling. After the hole has been drilled, insert a grommet to protect the cable.
- Route the cable along the factory wiring harness towards the battery. Install a 30 amp fuse block (customer supplied) on the end of the RED wire in the power cable. **NOTE: Remove the fuse from the fuse block before connecting any wires to the battery.**
- Connect the BLACK wire to Chassis Ground.

Connecting the Communication Cable:

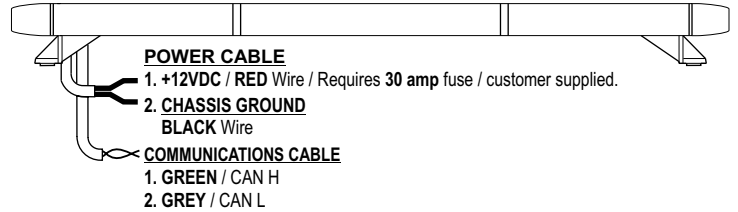

Splice the GREEN and GREY wires from the lightbar to the GREEN and GREY wires from the Controller.

Troubleshooting:

Your lightbar should now be fully operational. If it is not functioning properly, check your connections for the following:

- The positive wire (RED) is properly connected to the battery, by way of the user supplied fuse block.
- A working 30 amp fuse is installed in the fuse block.
- The ground wire (BLACK) is properly connected to the factory ground. Be sure that the wire is fully grounded to this location.
- The two communication wires (GREEN and GREY) are properly connected to their communication designations.

Refer to your controller instructions for connections and operation.

IMPORTANT! It is the responsibility of the installation technician to make sure that the installation and operation of this product will not interfere with or compromise the operation or efficiency of any vehicle equipment!

IMPORTANT WARNING!

CAUTION! DO NOT LOOK DIRECTLY AT THESE LED'S WHILE THEY ARE ON. MOMENTARY BLINDNESS AND/OR EYE DAMAGE COULD RESULT!

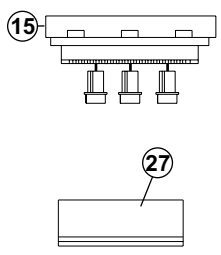
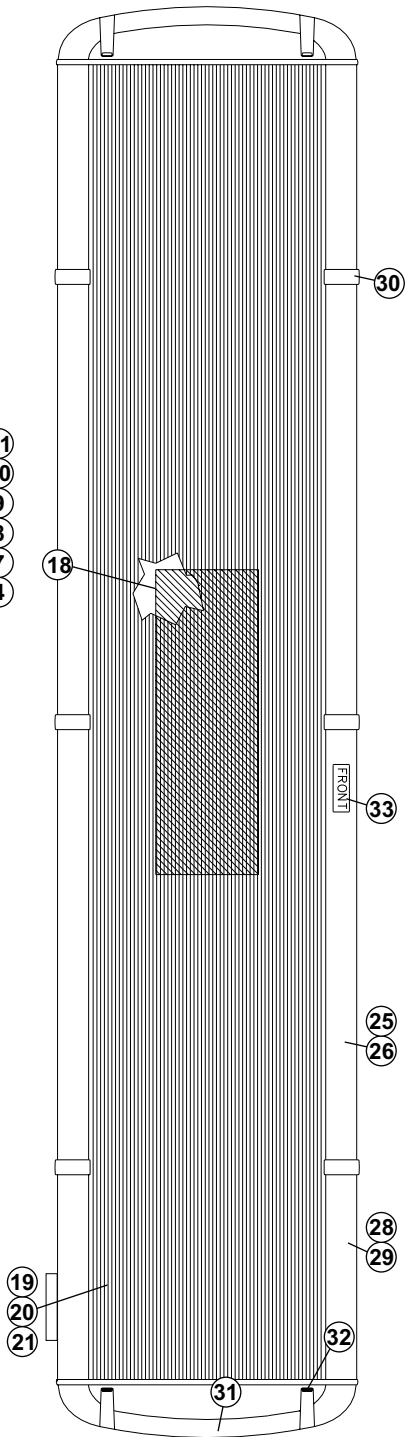
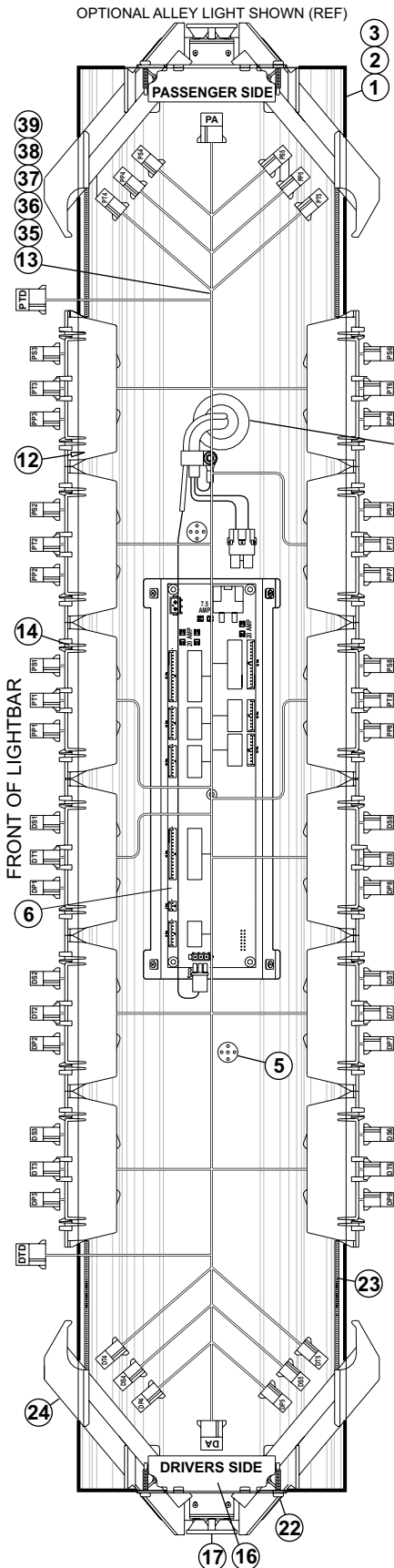

QTY	QTY	QTY	ITEM	PART NUMBER	DESCRIPTION
	*	*		01-0686912-00	LIBERTY 48.50" TRI COLOR
	*	*		01-0686912-01	LIBERTY 54.00" TRI COLOR
*				01-0686912-02	LIBERTY 43.13" TRI COLOR
-	-	1	1	11-363312-044	BASE, EXTRUDED (44.00")
-	1	-	2	11-363312-049	BASE, EXTRUDED (49.39")
1	-	-	3	11-363312-038	BASE, EXTRUDED (38.61")
1	1	1	4	21-11245004-1	GROMMET, 1.562"
2	2	2	5	21-7263998-00	PLUG, VENT (3/4")
1	1	1	6	01-026D153-00	ELECT WC DUO LIBERTY I/O
1	1	1	7	46-0743196-17	INPUT CABLE ASS'Y., (2C-10GA.) 17'
1	1	1	8	46-0743903-17	CABLE, 17/C 22GA (17')
1	1	1	9	14-0023347-00	SCREW, 10-24 x 1.25" TX PHD
1	1	1	10	26-0115663-10	CABLE CLAMP, 5/8"
1	1	1	11	13-104111-063	#10-24 WIZ NUT
10	12	12	12	11-483564-000	HOUSING, LIGHTHEAD (SNAP-IN)
1	1	1	13	46-0786890-00	HARNESS TRICOLOR LIBERTY
10	12	12	14	09-1363542-00	PANEL, FILLER
A/R	A/R	A/R	15	01-026D045	SUB ASSY, 500 TRI-COLOR
2	2	2	16	02-036B855-00	END SUPPORT BRACKET
A/R	A/R	A/R	17	01-026B855-30	LR11 ALLEY LIGHT (WHITE)
1	1	1	18	38-0142783-00	INSULATOR, FOAM PAD
-	-	1	19	11-26B607-044	TOP, EXTRUDED (44.00")
-	-	1	20	11-26B607-049	TOP, EXTRUDED (49.39")
1	-	-	21	11-26B607-038	TOP, EXTRUDED (38.61")
4	4	4	22	14-104216-06J	#10-24 X 3/8 PPH SCREW
-	4	-	23	07-243170-000	SPACER, CORNER
A/R	A/R	A/R	24	01-026D046	EXT CORNER TRI-COLOR LIBERTY
-	4	4	25	68-1983567-30	LENS, 15.800" LG. (CLEAR)
4	-	-	26	68-1963333C03	LENS, 10.500" LG. (CLEAR)
2	-	-	27	68-1983818-30	LENS, 5.062" LG. (CLEAR)
4	-	4	28	68-1983819-30	LENS, 5.687" LG. (CLEAR)
-	4	-	29	68-1963333C08	LENS, 8.375" LG. (CLEAR)
8	6	6	30	02-0342791-30	LENS DIVIDER (CLEAR)
2	2	2	31	02-036A035-30	SUB ASSY, ENDCAP CLEAR
8	8	8	32	14-104286-16JB	#10-24 X 1-1/4" TX. PHD. W/SHOULDER
1	1	1	33	10-0322935-00	LABEL, "FRONT" LIGHTBAR ASS'Y.
1	1	1	34	10-0522960-00	LABEL, MODEL & SERIAL # not shown
1	1	1	35	46-0786873-00	HARNESS PRIMARY DRIVER DUO LIBERTY
1	1	1	36	46-0786873-02	HARNESS PRIMARY PASS DUO LIBERTY
1	1	1	37	46-0786873-01	HARNESS SECONDARY DRIVER DUO LIBERTY
1	1	1	38	46-0786873-03	HARNESS SECONDARY PASS DUO LIBERTY
1	1	1	39	46-0786890-01	HARNESS TRICOLOR LIBERTY