

51 Winthrop Road
Chester, Connecticut 06412-0684
Phone: (860) 526-9504
Fax: (860) 526-4078
Sales Email: autosale@whelen.com
Canadian Sales: canadiansales@whelen.com
Customer Service: custserv@whelen.com

Safety First: This document provides all the necessary information to allow your Whelen product to be properly and safely installed. Before beginning the installation and/or operation of your new product, the installation technician and operator must read this manual completely. Important information is contained herein that could prevent serious injury or damage.

- Proper installation of this product requires the installer to have a good understanding of automotive electronics, systems and procedures.
- Whelen Engineering requires the use of waterproof butt splices and/or connectors if that connector could be exposed to moisture.
- Failure to use specified installation parts and/or hardware will void the product warranty!
- If mounting this product requires drilling holes, the installer MUST be sure that no vehicle components or other vital parts could be damaged by the drilling process. Check both sides of the mounting surface before drilling begins. Also de-burr any holes and remove any metal shards or remnants. Install grommets into all wire passage holes.
- Do not install this product or route any wires in the deployment area of your air bag. Equipment mounted or located in the air bag deployment area will damage or reduce the effectiveness of the air bag, or become a projectile that could cause serious personal injury or death. Refer to your vehicle owner's manual for the air bag deployment area. The User/Installer assumes full responsibility to determine proper mounting location, based on providing ultimate safety to all passengers inside the vehicle.
- For this product to operate at optimum efficiency, a good electrical connection to chassis ground must be made. The recommended procedure requires the product ground wire to be connected directly to the NEGATIVE (-) battery post.
- If this product uses a remote device to activate or control this product, make sure that this control is located in an area that allows both the vehicle and the control to be operated safely in any driving condition.
- Do not attempt to activate or control this device in a hazardous driving situation.
- This product contains either strobe light(s), halogen light(s), high-intensity LEDs or a combination of these lights. Do not stare directly into these lights. Momentary blindness and/or eye damage could result.
- Use only soap and water to clean the outer lens. Use of other chemicals could result in premature lens cracking (crazing) and discoloration. Lenses in this condition have significantly reduced effectiveness and should be replaced immediately. Inspect and operate this product regularly to confirm its proper operation and mounting condition. Do not use a pressure washer to clean this product.
- **WARNING!** All customer supplied wires that connect to the positive (+) terminal of the battery must be sized to supply at least 125% of the maximum operating current and **FUSED** "at the battery" to carry that load. **DO NOT USE CIRCUIT BREAKERS WITH THIS PRODUCT!**
- **FAILURE TO FOLLOW THESE PRECAUTIONS AND INSTRUCTIONS COULD RESULT IN DAMAGE TO THE PRODUCT OR VEHICLE AND/OR SERIOUS INJURY TO YOU AND YOUR PASSENGERS!**

Wiring:

Ground (BLK or BLK/WHT): Extend this wire to chassis ground.

Warning Light (RED/WHT, RED or BLU): Extend this wire to +12VDC via a customer supplied SP/ST switch. Fuse this wire @ 3 Amps. **Note: When Warning Light is active, the driving lights (White LEDs) will not operate.**

Driving Light (WHT): Extend this wire to +12VDC via a customer supplied SP/ST switch. Fuse this wire @ 3 Amps. **Note: Warning Light operation will override driving light operation.**

Scan-Lock™ (WHT/VIO): Extend this wire to +VBAT via a customer supplied Normally Open momentary switch. Fuse this wire @ 1 Amps.

To Change Patterns: To advance to the next pattern, apply +VBAT to the WHT/VIO wire for less than 1 second and release. To cycle back to the previous pattern, apply +VBAT to the WHT/VIO wire for more than 1 second and release.

To Change The Default Pattern: When the desired pattern is displayed, allow it to run for more than 5 seconds. The warning lights will now display this pattern when initially activated.

To Restore The Factory Default Pattern: With the power to the warning lights off, apply +VBAT to the WHT/VIO wire. With the WHT/VIO wire still activated, turn power to the warning lights on.

Patterns

1. SignalAlert™ 75	ALT	18. SingleFlash 90	ALT	35. DoubleFlash 120	SIM
2. SignalAlert 75	SIM	19. SingleFlash 90	SIM	36. PingPong™ 120	ALT
3. CometFlash® 75	ALT	20. SingleFlash 120	ALT	37. PingPong 120	SIM
4. CometFlash 75	SIM	21. SingleFlash 120	SIM	38. TripleFlash™ 75	ALT
5. DoubleFlash 75	ALT	22. SingleFlash 300	ALT	39. TripleFlash 75	SIM
6. DoubleFlash 75	SIM	23. SingleFlash 300	SIM	40. TripleFlash 120	ALT
7. SingleFlash 75	ALT	24. DoubleFlash 150	ALT	41. TripleFlash 120	SIM
8. SingleFlash 75	SIM	25. DoubleFlash 150	SIM	42. SigAlert Cal.™	ALT
9. ComAlert™ 75	ALT	26. ComAlert 150	ALT	43. SigAlert Cal.	SIM
10. ComAlert 75	SIM	27. ComAlert 150	SIM	44. Action 1	ALT
11. LongBurst™ 75	ALT	28. ActionFlash™50	ALT	45. Action 1	SIM
12. LongBurst™ 75	SIM	29. ActionFlash 50	SIM	46. Action 2	ALT
13. PingPong™ 75	ALT	30. ActionFlash 150	ALT	47. Action 2	SIM
14. PingPong™ 75	SIM	31. ActionFlash 150	SIM	48. CalScan™	ALT/SIM
15. SSNF 75		32. ModuFlash™	ALT	49. ActionScan™	ALT/SIM
16. SingleFlash 60	ALT	33. ModuFlash	SIM	50. Steady	
17. SingleFlash 60	SIM	34. DoubleFlash 120	ALT		

Flash Pattern Notes:

ALT (Alternating):

With a RED/BLU light, RED will alternate with BLUE.
With a RED or BLUE light, RED or BLUE will alternate from top to bottom.

SIM (Simultaneous):

With a RED/BLUE light, both RED and BLUE will light up simultaneously.
With an all RED or all BLUE light, the whole light will light up RED or BLUE.

BOLD = California Title 13 compliant.

It is the responsibility of the installation technician to make sure that the installation and operation of this product will not interfere with or compromise the operation or efficiency of any vehicle equipment!

Before returning the vehicle to active service, visually confirm the proper operation of this product, as well as all vehicle components/equipment.

IMPORTANT WARNING!

CAUTION! DO NOT LOOK DIRECTLY AT THESE LEDES WHILE THEY ARE ON. MOMENTARY BLINDNESS AND/OR EYE DAMAGE COULD RESULT!

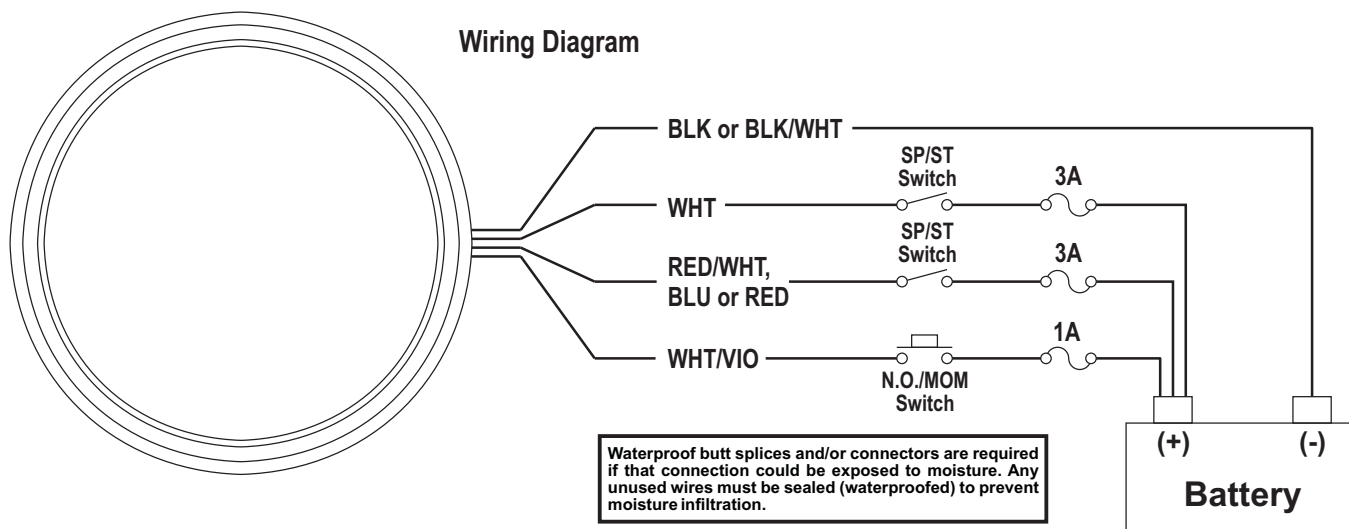

Waterproof butt splices and/or connectors are required if that connection could be exposed to moisture. Any unused wires must be sealed (waterproofed) to prevent moisture infiltration.

Warnings to Installers

Whelen's emergency vehicle warning devices must be properly mounted and wired in order to be effective and safe. Read and follow all of Whelen's written instructions when installing or using this device. Emergency vehicles are often operated under high speed stressful conditions which must be accounted for when installing all emergency warning devices. Controls should be placed within convenient reach of the operator so that he can operate the system without taking his eyes off the roadway. Emergency warning devices can require high electrical voltages and/or currents. Properly protect and use caution around live electrical connections. Grounding or shorting of electrical connections can cause high current arcing, which can cause personal injury and/or vehicle damage, including fire. Many electronic devices used in emergency vehicles can create or be affected by electromagnetic interference. Therefore, after installation of any electronic device it is necessary to test all electronic equipment simultaneously to insure that they operate free of interference from other components within the vehicle. Never power emergency warning equipment from the same circuit or share the same grounding circuit with radio communication equipment. All devices should be mounted in accordance with the manufacturer's instructions and securely fastened to vehicle elements of sufficient strength to withstand the forces applied to the device. Driver and/or passenger air bags (SRS) will affect the way equipment should be mounted. This device should be mounted by permanent installation and within the zones specified by the vehicle manufacturer, if any. Any device mounted in the deployment area of an air bag will damage or reduce the effectiveness of the air bag and may damage or dislodge the device. Installer must be sure that this device, its mounting hardware and electrical supply wiring does not interfere with the air bag or the SRS wiring or sensors. Mounting the unit inside the vehicle by a method other than permanent installation is not recommended as unit may become dislodged during swerving; sudden braking or collision. Failure to follow instructions can result in personal injury. Whelen assumes no liability for any loss resulting from the use of this warning device. **PROPER INSTALLATION COMBINED WITH OPERATOR TRAINING IN THE PROPER USE OF EMERGENCY WARNING DEVICES IS ESSENTIAL TO INSURE THE SAFETY OF EMERGENCY PERSONNEL AND THE PUBLIC.**

Warnings to Users

Whelen's emergency vehicle warning devices are intended to alert other operators and pedestrians to the presence and operation of emergency vehicles and personnel. However, the use of this or any other Whelen emergency warning device does not guarantee that you will have the right-of-way or that other drivers and pedestrians will properly heed an emergency warning signal. Never assume you have the right-of-way. It is your responsibility to proceed safely before entering an intersection, driving against traffic, responding at a high rate of speed, or walking on or around traffic lanes. Emergency vehicle warning devices should be tested on a daily basis to ensure that they operate properly. When in actual use, the operator must ensure that both visual and audible warnings are not blocked by vehicle components (i.e.: open trunks or compartment doors), people, vehicles, or other obstructions. It is the user's responsibility to understand and obey all laws regarding emergency warning devices. The user should be familiar with all applicable laws and regulations prior to the use of any emergency vehicle warning device. Whelen's audible warning devices are designed to project sound in a forward direction away from the vehicle occupants. However, because sustained periodic exposure to loud sounds can cause hearing loss, all audible warning devices should be installed and operated in accordance with the standards established by the National Fire Protection Association.