

WHELEN[®]

ENGINEERING COMPANY INC.

51 Winthrop Road
 Chester, Connecticut 06412-0684
 Phone: (860) 526-9504
 Fax: (860) 526-2009
 Internet: www.whelen.com
 Sales/Service e-mail: aviation@whelen.com

Installation Guide: Aviation model 9061201, 9061202 P/N 01-0790612-01, 01-0790612-02 LED Position / Anti-Collision and Infrared Light Assembly



MADE IN THE U.S.A.
TSO-C30c
TYPE I, II & III;
APPROVED

TSO-C96a
CLASS I;
APPROVED

The conditions and tests required for TSO approval of this article are minimum performance standards. It is the responsibility of those installing this article either on or within a specific type or class of aircraft to determine that the aircraft installation conditions are within the TSO standards. TSO articles must have separate approval for installation in aircraft. The article may be installed only if performed under 14 CFR part 43 or the applicable airworthiness requirements.

EQUIPMENT LIMITATIONS:

An approved lighting system consists of two lights, one located on each wingtip. The baseplate must be mounted parallel to the vertical and horizontal centerlines of the aircraft to project the patterns properly. A separate flasher assembly, such as model 7145702, is required for each light assembly.

The Infrared light is a non-TSO function.

Certain types of installations may require additional testing.

CONTINUED AIRWORTHINESS:

The forward position light is designed with 4 Green LEDs or 5 Red LEDs. The tail position light is designed with 2 LEDs. The anti-collision light is designed with 36 LEDs.

If any one bank of LEDs fails, the flasher module should be checked. If module checks good, replace the lighthouse. If any one LED fails, the unit must be repaired or replaced.

Note: To reduce eye strain, use an optical filter such as dark glasses or a blue covering dome during LED inspection.

Inspect the lens. Replace if there is excessive scratching, pitting, discoloration or cracking.

Note: The anti-collision light will automatically shut-off after 9-10 flashes if a failure is detected by flasher assembly model 7145702.

INSTALLATION PROCEDURES:

The following information is to assist you in installing a Whelen light system. The installation procedure described in the following text will be confined to a single light installation, but is identical for multiple light installations.

1. Choose the appropriate Model 90612() light assembly.
2. Using the mounting detail information on page 2, prepare the aircraft for means to secure the LED light assembly. Remove any existing mounting adapters.
3. Connect the light inputs according to the chart shown. Connections to be in accordance with FAA approved methods.
4. Remove the lens retainers and carefully remove the lens. Using appropriate hardware, install the light assembly and insure that all leads are clear of any obstructions. Ty-rap as required. Secure the light assembly using vibration resistant threaded fasteners.
5. Carefully reinstall the lens and retainers.

6. Waterproof the lightbase to aircraft. Apply single-part Silicone (RTV) or equivalent around any open area where water could get in.
7. Check all avionics systems for interference from this installation.
8. A flight check should be performed by a properly certified pilot.
9. Update aircraft records, complete Form 337 and obtain FAA field approval for installation, as required.

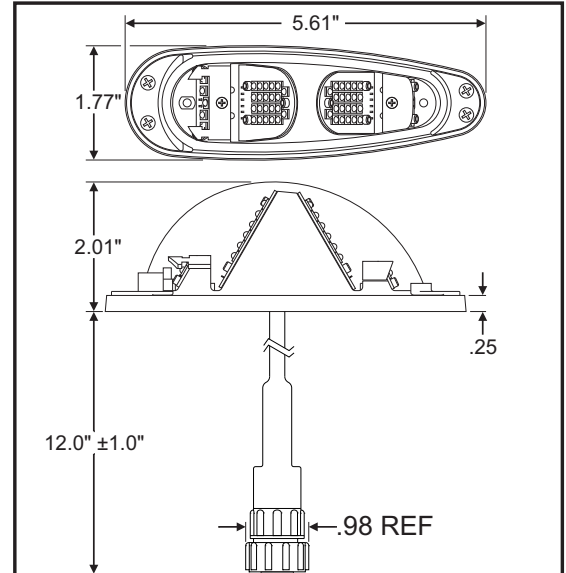

CPC 206485-1		22759/43 WIRES
1	Ac1	Anti-Collision Light 20 AWG
2	AC2	Anti-Collision Light 20 AWG
3	AC3	Anti-Collision Light 20 AWG
4	AC4	Anti-Collision Light 20 AWG
5	V+	V IN 18 AWG
6	AC5	Anti-Collision Light 20 AWG
7	AC6	Anti-Collision Light 20 AWG
8	Cathode	FWD & AFT Position Lights 20 AWG
9	Cathode	IR Lights 20 AWG

Aviation

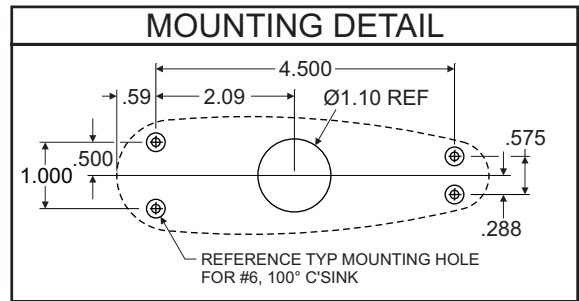
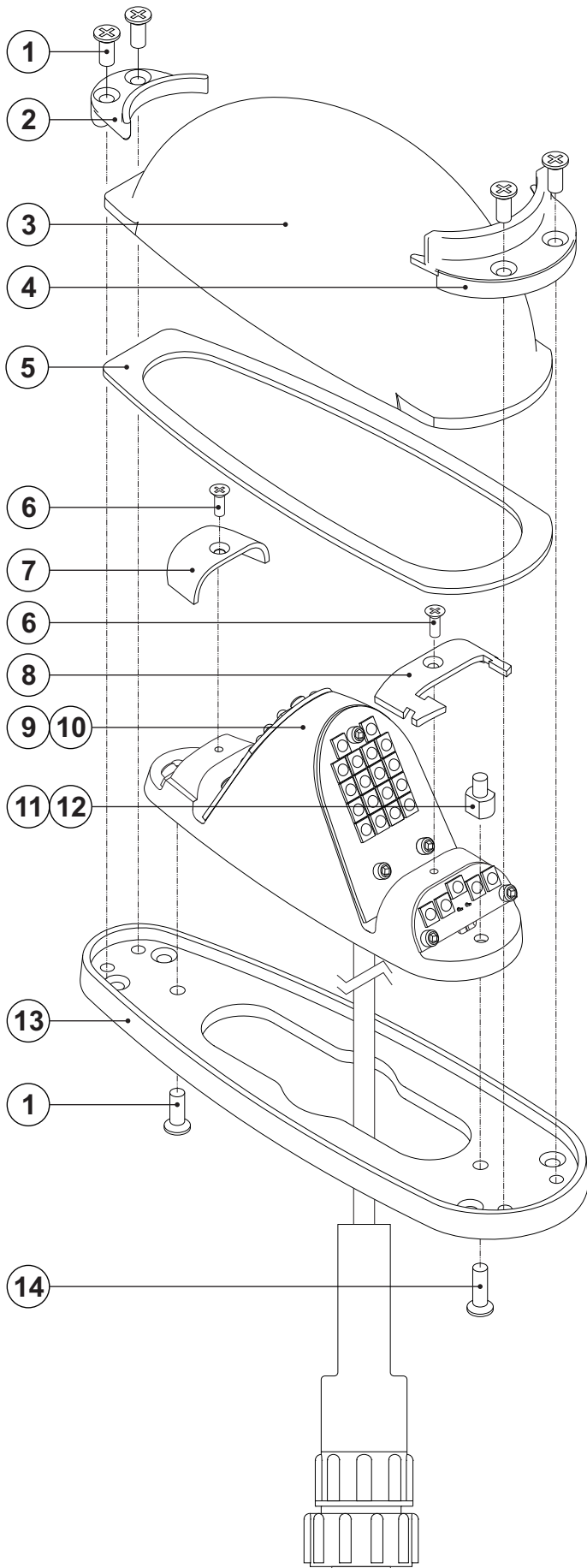

QTY	QTY	ITEM	PART NUMBER	DESCRIPTION
	*		01-0790612-01	ASS'Y, GREEN POS. / A-C / INFRARED LIGHT
	*		01-0790612-02	ASS'Y, RED POS. / A-C / INFRARED LIGHT
5	5	1	14-0050581B03	SCREW, 4-40 X 5/16 PFHMS 100° C'sk
1	1	2	19-151003-100	RETAINER, REAR
1	1	3	68-3990574A30	LENS, HARDCOATED
1	1	4	19-171471-100	RETAINER, FRONT
1	1	5	38-0231219-00	GASKET, LENS
2	2	6	14-026116-04M	SCREW, 2-56 X 1/4 P82FHMS SS w/NYLON
1	1	7	11-651008-000	SHROUD, TAIL POSITION LIGHT
1	1	8	11-651016-000	SHROUD, FORWARD POSITION LIGHT
-	1	9	01-0271597-01	ASS'Y, LIGHTHEAD MODEL 9061201, GREEN
1	-	10	01-0271597-02	ASS'Y, LIGHTHEAD MODEL 9061202, RED
1	1	11	68-5451007-00	REFLECTOR, 90°
A/R	A/R	12	66-0715403-00	Threadlocker, 242 Loctite 50ml
1	1	13	06-171472-200	BASE PLATE
1	1	14	14-0050581-05	SCREW, 4-40 X 7/16 PFHMS 100° C'sk