

WHELEN[®]

ENGINEERING COMPANY INC.

51 Winthrop Road
Chester, Connecticut 06412-0684
Phone: (860) 526-9504
Fax: (860) 526-4078
Internet: www.whelen.com
Sales e-mail: autosale@whelen.com
Canadian Sales e-mail: canadiansales@whelen.com
Customer Service e-mail: custserv@whelen.com

Field Service Procedure: Lens/Endcap Installation Notes

1. Preparation - Extrusion

Using the tool provided, deburr the extrusion at the 4 locations where the upper lens rail engages the extrusion. DO NOT COUNTERSINK

2. Preparation - Lens

Apply a coating of P-80 lubricant (provided) the entire length of the black seal along the top of the lens. Be sure to coat the lens wherever it engages the extrusion

3. Preparation - Lens

Apply a coating of P-80 lubricant (provided) where the outside of the lens contacts the inside of the endcap.

4. Preparation - Endcap

Apply a coating of P-80 lubricant (provided) along the inside of the endcap where it contacts the lens.

Assembly Note

- When installing the endcap, be sure to slide the endcap evenly onto the lens/extrusion assembly.

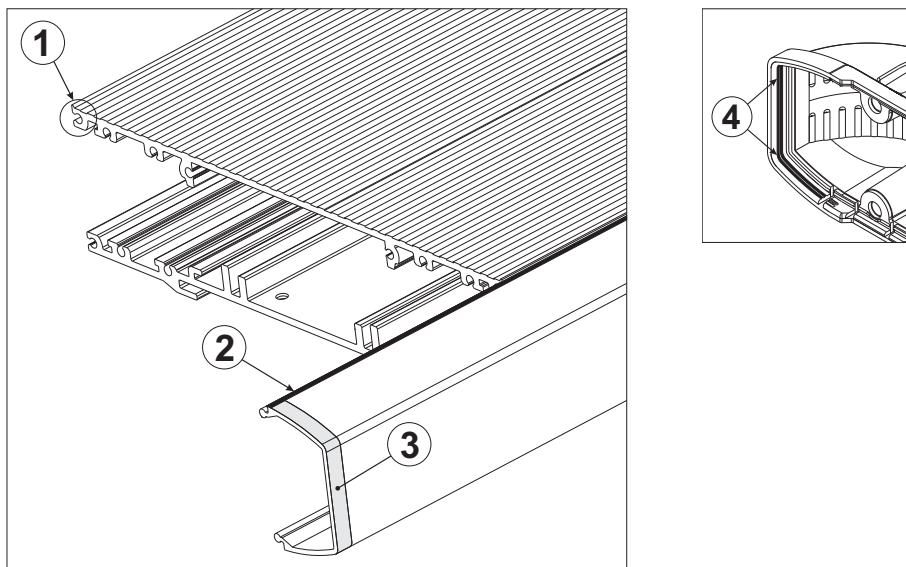

For warranty information regarding this product, visit www.whelen.com/warranty