

# WHELEN<sup>®</sup>

ENGINEERING COMPANY INC.

51 Winthrop Road  
 Chester, Connecticut 06412-0684  
 Phone: (860) 526-9504  
 Fax: (860) 526-2009  
 Internet: [www.whelen.com](http://www.whelen.com)  
 Sales/Service e-mail: [aviation@whelen.com](mailto:aviation@whelen.com)

## Installation Guide: Aviation model(s) OR6501GE, OR6501RE P/N 01-0790701-01, 01-0790701-02 Orion 650E Wingtip Position/Anti-Collision Lighthouse

TSO-C30c  
 TYPE I & II;  
 APPROVED



TSO-C96a  
 CLASS II;  
 APPROVED

The conditions and tests required for TSO approval of this article are minimum performance standards. It is the responsibility of those installing this article either on or within a specific type or class of aircraft to determine that the aircraft installation conditions are within the TSO standards. TSO articles must have separate approval for installation in aircraft. The article may be installed only if performed under 14 CFR part 43 or the applicable airworthiness requirements.

### SPECIFICATIONS:

Nominal Operational Voltage: ..... 12VDC  
 (Operational from 9-14VDC)  
**Input Current:**  
 Position Lights ..... 0.3 Amps  
 Anti-Collision Light (Avg.) ..... 0.7 Amps  
 Anti-Collision Light (Pulse) ..... 3.6Amps  
 Flashrate ..... 45 ± 5 FPM

### EQUIPMENT LIMITATIONS:

An approved forward position lighting system consists of three lights, one located on the tail and one located on each wingtip. Model OR650( )E is a wingtip position and anti-collision light. The assembly should be mounted as far outboard on the aircraft as practical. The baseplate must be mounted parallel to the vertical and horizontal centerlines of the aircraft to project the patterns properly. This assembly must be mounted behind a clear lens.

Certain types of installations may require additional testing.

### CONTINUED AIRWORTHINESS:

The forward position light is designed with green or red LEDs. The anti-collision light is designed with 24 white LEDs. If any one LED fails, the unit must be repaired or replaced.

**Note:** To reduce eye strain, use an optical filter such as dark glasses or a blue covering dome during LED inspection.

### INSTALLATION PROCEDURES:

The following information is to assist you in installing a Whelen light system.

1. Choose the appropriate light assembly.
2. Using the mounting detail information provided, prepare the aircraft for means to secure the light assembly.
3. Carefully remove the #4 phillips head screw (qty. 4). Remove the light assembly from the baseplate. **CAUTION! Do not touch the LED with either fingers or sharp objects. This could soil and/or damage the lens and affect the optical performance of the LEDs.**
4. Using the appropriate hardware install the baseplate to the aircraft.
5. Route the wires through the opening in the baseplate. Connect the light inputs according to the chart shown. Connect the power lead to an appropriately sized breaker. Connections to be according to FAA approved methods.  
 Note: SYNC is a low-power, bi-directional control signal. Connecting to the synchronize signal of any Whelen LED anti-collision assembly to another Whelen anti-collision assembly will cause the lights to flash at the same time. If Synchronization is not necessary, the connection may be left open.
6. Re-install the light assembly on to the baseplate and insure that all leads are clear of any obstructions and secured as required.
7. Check all avionics systems for interference from this installation.
8. A flight check should be performed by a properly certified pilot.
9. Update aircraft records, complete Form 337 and obtain FAA field approval for installation, if required.

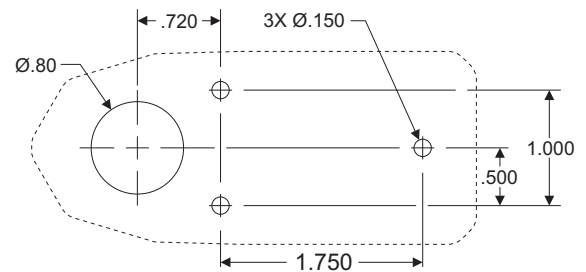

SUGGESTED MOUNTING DETAIL

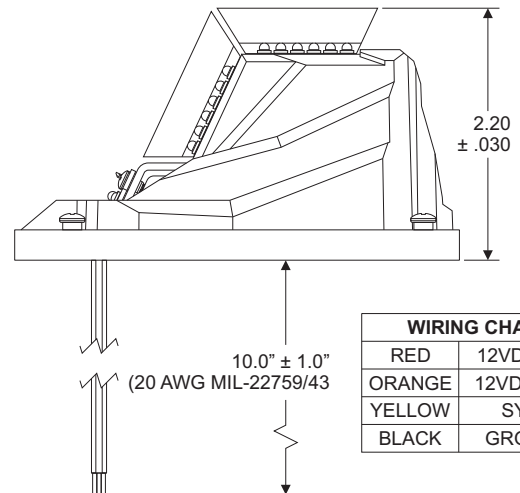
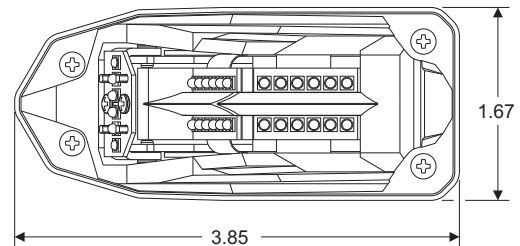

WIRING CHART	
RED	12VDC ACL
ORANGE	12VDC POS
YELLOW	SYNC
BLACK	GROUND

Aviation

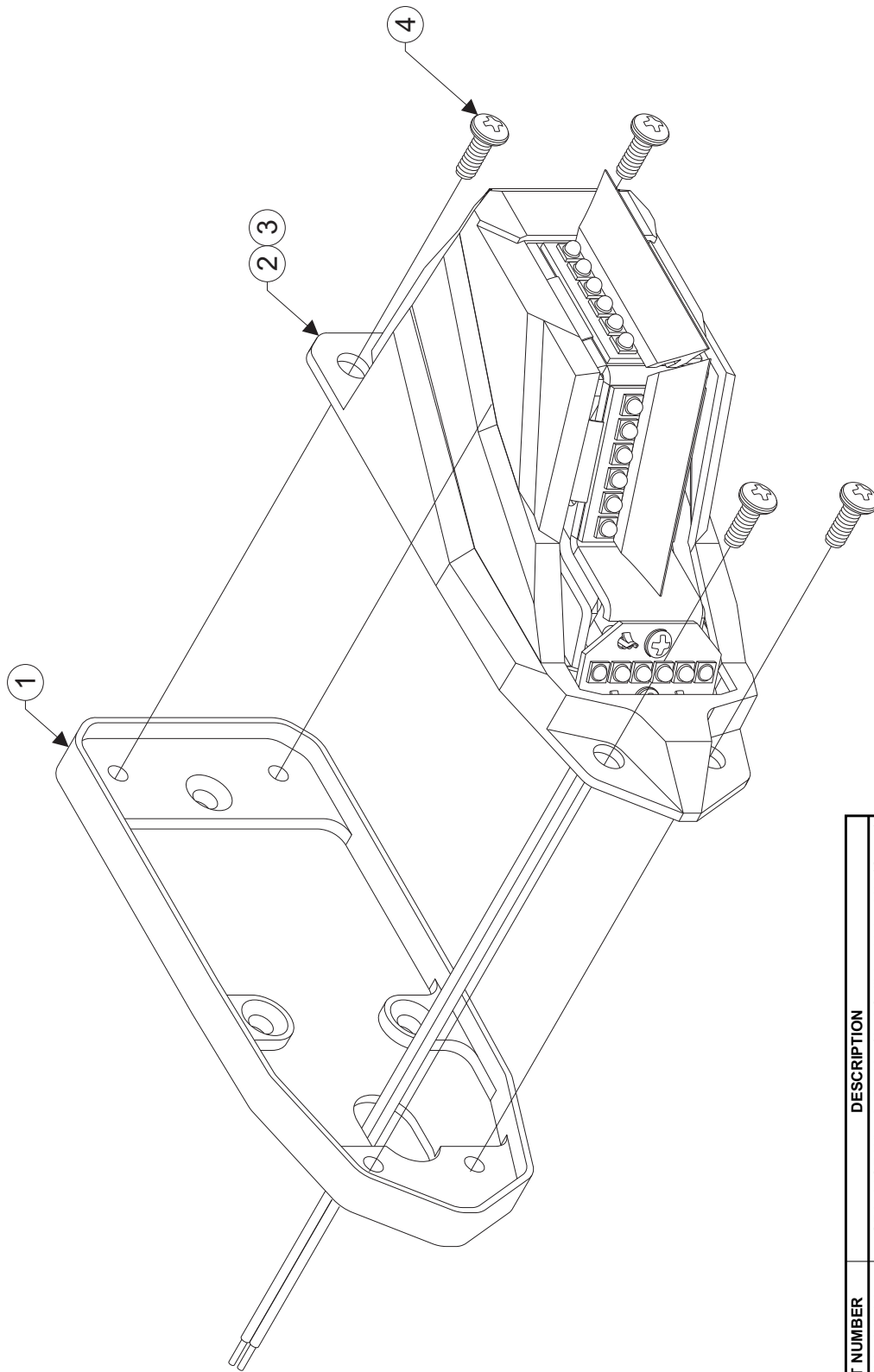

QTY	QTY/ITEM	PART NUMBER	DESCRIPTION
*		01-0790701-01	OR6501GE Wingtip Position/Anti-Collision Light, 12V (Green)
*		01-0790701-02	OR6501RE Wingtip Position/Anti-Collision Light, 12V (Red)
1	1	07-771790-100	Mounting Plate
-	1	2	Sub-Assy, Model OR6501GE (12 VDC, GRN)
1	-	3	Sub-Assy, Model OR6501RE (12 VDC, RED)
4	4	14-0050505-14	Screw, #4-40 x 5/16, PPHMS (MS51957-14)