

WHELEN[®]

ENGINEERING COMPANY INC.

51 Winthrop Road
Chester, Connecticut 06412-0684
Phone: (860) 526-9504
Fax: (860) 526-4078
Internet: www.whelen.com
Sales e-mail: autosale@whelen.com
Canadian Sales e-mail: canadiansales@whelen.com
Customer Service e-mail: custserv@whelen.com

Installation Guide:
Mirror-Beam™ Super-LED® Lighthouse
2015 Chevrolet Tahoe
Model MBCT15 ION™ Series™**
Model VMCT15 ION™ V-Series™**

Warnings to Installers

Whelen's emergency vehicle warning devices must be properly mounted and wired in order to be effective and safe. Read and follow all of Whelen's written instructions when installing or using this device. Emergency vehicles are often operated under high speed stressful conditions which must be accounted for when installing all emergency warning devices. Controls should be placed within convenient reach of the operator so that he can operate the system without taking his eyes off the roadway. Emergency warning devices can require high electrical voltages and/or currents. Properly protect and use caution around live electrical connections. Grounding or shorting of electrical connections can cause high current arcing, which can cause personal injury and/or vehicle damage, including fire. Many electronic devices used in emergency vehicles can create or be affected by electromagnetic interference. Therefore, after installation of any electronic device it is necessary to test all electronic equipment simultaneously to insure that they operate free of interference from other components within the vehicle. Never power emergency warning equipment from the same circuit or share the same grounding circuit with radio communication equipment. All devices should be mounted in accordance with the manufacturer's instructions and securely fastened to vehicle elements of sufficient strength to withstand the forces applied to the device. Driver and/or passenger air bags (SRS) will affect the way equipment should be mounted. This device should be mounted by permanent installation and within the zones specified by the vehicle manufacturer, if any. Any device mounted in the deployment area of an air bag will damage or reduce the effectiveness of the air bag and may damage or dislodge the device. Installer must be sure that this device, its mounting hardware and electrical supply wiring does not interfere with the air bag or the SRS wiring or sensors. Mounting the unit inside the vehicle by a method other than permanent installation is not recommended as unit may become dislodged during swerving; sudden braking or collision. Failure to follow instructions can result in personal injury. Whelen assumes no liability for any loss resulting from the use of this warning device. **PROPER INSTALLATION COMBINED WITH OPERATOR TRAINING IN THE PROPER USE OF EMERGENCY WARNING DEVICES IS ESSENTIAL TO INSURE THE SAFETY OF EMERGENCY PERSONNEL AND THE PUBLIC.**

Warnings to Users

Whelen's emergency vehicle warning devices are intended to alert other operators and pedestrians to the presence and operation of emergency vehicles and personnel. However, the use of this or any other Whelen emergency warning device does not guarantee that you will have the right-of-way or that other drivers and pedestrians will properly heed an emergency warning signal. Never assume you have the right-of-way. It is your responsibility to proceed safely before entering an intersection, driving against traffic, responding at a high rate of speed, or walking on or around traffic lanes. Emergency vehicle warning devices should be tested on a daily basis to ensure that they operate properly. When in actual use, the operator must ensure that both visual and audible warnings are not blocked by vehicle components (i.e.: open trunks or compartment doors), people, vehicles, or other obstructions. It is the user's responsibility to understand and obey all laws regarding emergency warning devices. The user should be familiar with all applicable laws and regulations prior to the use of any emergency vehicle warning device. Whelen's audible warning devices are designed to project sound in a forward direction away from the vehicle occupants. However, because sustained periodic exposure to loud sounds can cause hearing loss, all audible warning devices should be installed and operated in accordance with the standards established by the National Fire Protection Association.

Safety First

This document provides all the necessary information to allow your Whelen product to be properly and safely installed. Before beginning the installation and/or operation of your new product, the installation technician and operator must read this manual completely. Important information is contained herein that could prevent serious injury or damage.

- **Proper installation of this product requires the installer to have a good understanding of automotive electronics, systems and procedures.**
- **Whelen Engineering requires the use of waterproof butt splices and/or connectors if that connector could be exposed to moisture.**
- **Failure to use specified installation parts and/or hardware will void the product warranty.**
- **If mounting this product requires drilling holes, the installer MUST be sure that no vehicle components or other vital parts could be damaged by the drilling process. Check both sides of the mounting surface before drilling begins. Also de-burr the holes and remove any metal shards or remnants. Install grommets into all wire passage holes.**
- **If this manual states that this product may be mounted with suction cups, magnets, tape or Velcro®, clean the mounting surface with a 50/50 mix of isopropyl alcohol and water and dry thoroughly.**
- **Do not install this product or route any wires in the deployment area of your air bag. Equipment mounted or located in the air bag deployment area will damage or reduce the effectiveness of the air bag, or become a projectile that could cause serious personal injury or death. Refer to your vehicle owner's manual for the air bag deployment area. The User/Installer assumes full responsibility to determine proper mounting location, based on providing ultimate safety to all passengers inside the vehicle.**
- **For this product to operate at optimum efficiency, a good electrical connection to chassis ground must be made. The recommended procedure requires the product ground wire to be connected directly to the NEGATIVE (-) battery post (this does not include products that use cigar power cords).**
- **If this product uses a remote device for activation or control, make sure that this device is located in an area that allows both the vehicle and the device to be operated safely in any driving condition.**
- **Do not attempt to activate or control this device in a hazardous driving situation.**
- **This product contains either strobe light(s), halogen light(s), high-intensity LEDs or a combination of these lights. Do not stare directly into these lights. Momentary blindness and/or eye damage could result.**
- **Use only soap and water to clean the outer lens. Use of other chemicals could result in premature lens cracking (crazing) and discoloration. Lenses in this condition have significantly reduced effectiveness and should be replaced immediately. Inspect and operate this product regularly to confirm its proper operation and mounting condition. Do not use a pressure washer to clean this product.**
- **It is recommended that these instructions be stored in a safe place and referred to when performing maintenance and/or reinstallation of this product.**
- **FAILURE TO FOLLOW THESE SAFETY PRECAUTIONS AND INSTRUCTIONS COULD RESULT IN DAMAGE TO THE PRODUCT OR VEHICLE AND/OR SERIOUS INJURY TO YOU AND YOUR PASSENGERS!**

To install this product, you must remove both side mirror assemblies from the vehicle. Following manufacturers instructions, unplug the mirror assembly harnesses and remove both mirror assemblies.

Preparing Mirror Assembly:

1. When drilling the wire hole be careful not to hit the mirror wiring harness. The location of the mirror wiring harness is shown (Fig. 1). There is also an inner support structure inside the mirror which you must avoid. Measure 4 inches from the inside edge and 2-1/2 inches from the top edge of the mirror cover as shown to locate the center of the wire hole and mark the location off onto the cover.

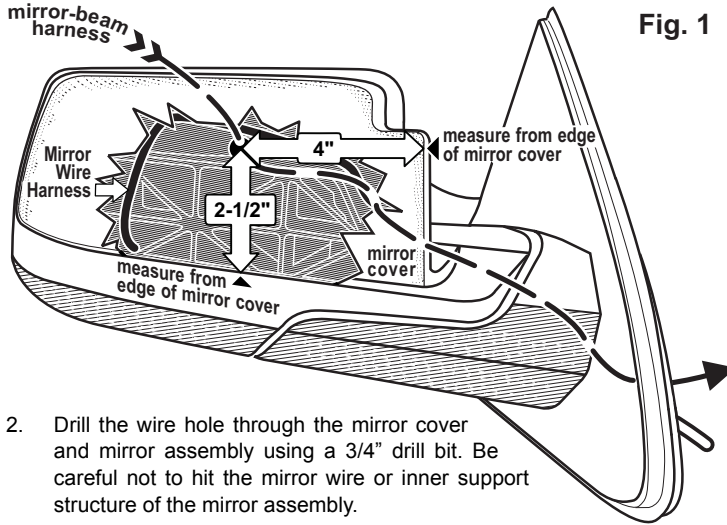

Fig. 1

2. Drill the wire hole through the mirror cover and mirror assembly using a 3/4" drill bit. Be careful not to hit the mirror wire or inner support structure of the mirror assembly.

The Mirror-Beam™ cable:

Because the Mirror-Beam™ cable must be routed through a narrow and twisting path within the mirror assembly, it will be necessary to temporarily extend the length of the cable.

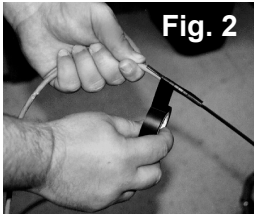

Fig. 2

1. Locate the ty-wrap (included) and cut the fastener-end off.
2. Locate the end of the cable that has PIN terminals installed on the wires. Cut off the non-insulated wire (not used) and strongly

secure the ty-wrap to the cable with electrical or similar tape. It is important to have a sufficient length of the ty-wrap secured to the cable (2" minimum) (Fig. 2).

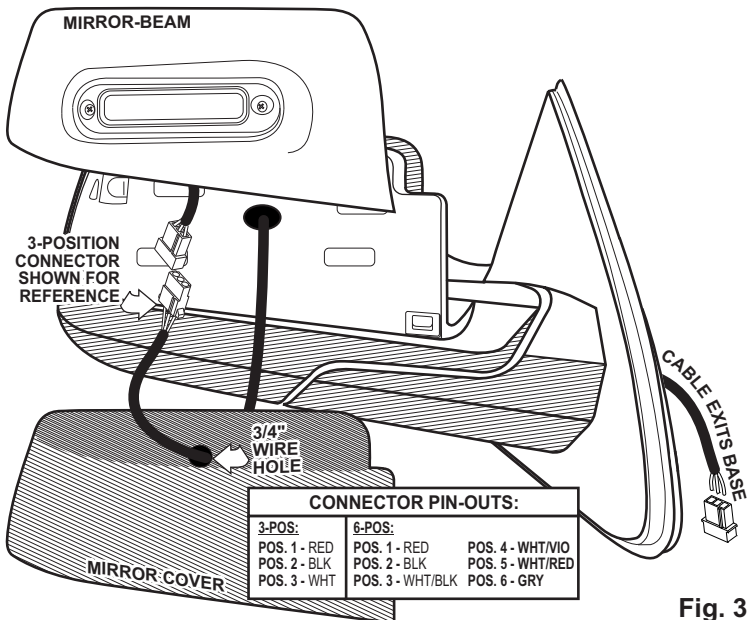

Fig. 3

Routing the Mirror-Beam™ Cable:

1. Remove the wire access panel from the bottom of the mirror assembly to access the wire harness pathway (Fig. 4)

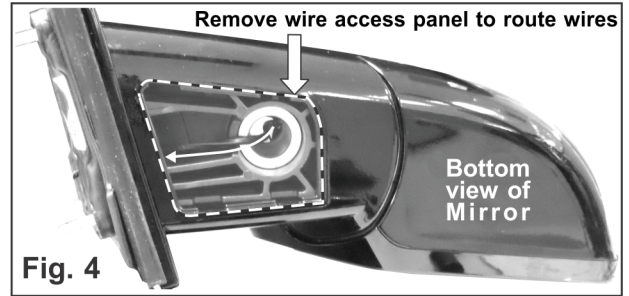

Fig. 4

2. Insert ty-wrap into the front of the mirror assembly (Figs. 1 & 2) and route the Mirror-Beam™ cable into the assembly and out the base, following the path of the mirror assembly harness. There should be 4 to 5" of cable protruding from the front of the mirror assembly.
3. Insert the other end of the cable into the hole you drilled in the mirror assembly cover and install the cover and wire access panel back onto the mirror assembly.

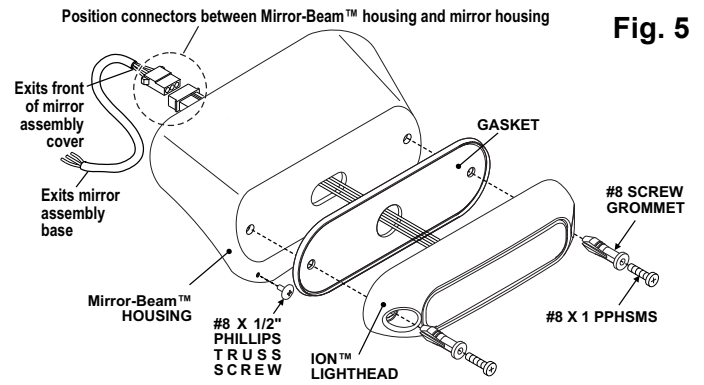

Fig. 5

4. Remove the ty-wrap from the cable. Install the connector (supplied) onto the end of the cable coming from the front of the mirror assembly (See Fig. 3 for connector pin-outs).

Affixing Mirror-Beam™ Housing to Mirror Assembly:

1. Remount the mirror assembly onto the vehicle and reconnect the mirror power cable to the mirror assembly. Route the Mirror-Beam™ cable through the door, along the same path as the vehicle's main power harness. Make sure that neither of the harness cables are crimped or pinched.
2. Mount the lighthead to the Mirror-Beam™ housing and plug the lighthead into the connector coming from the front of the mirror assembly. This connection will be tucked between the Mirror-Beam™ housing and the mirror assembly (Fig. 4).
3. **NOTE: The following procedure requires that the mirror assembly be no colder than 60°F (18°C).** Clean the plastic mirror assembly and the inside surface of the Mirror-Beam™ housing using a 50/50 mixture of isopropyl alcohol and water. Dry completely.
4. Locate the two, 6" strips of double-sided adhesive tape (included). Peel the protective strip from one side of one piece of tape and mount it along the rear (mirror side) edge, along the top of the mirror assembly cover, starting near the center of the cover and curving around to the outboard side. Apply pressure to the protective backing so that the tape adheres to the surface.
5. Using the procedure outlined in step 4, adhere the other piece of tape along the edge of the mirror assembly cover starting on the inboard side.
6. Hold the Mirror-Beam™ housing in position on the mirror assembly and trim and remove any exposed tape. Remove the

housing and fold the protective backing strips of the tape so that 1/2" to 3/4" of backing is extended over the edge of the mirror assembly.

- Mount the Mirror-Beam™ housing onto the mirror assembly. **The housing must fully engage the mirror assembly.** Press the housing firmly onto the exposed tape.
- The remaining protective backing strips must now be removed. The housing must not be in contact with the backing strips. Starting on top, and using a small flat blade screwdriver, gently pry the housing about 1/4" away from the mirror assembly. Carefully pull the protective strip "tab" created in step 6, and gently remove it completely from the tape strip. **Do not allow the strip to tear.** Repeat for the other tape strip.
- Apply pressure to the Mirror-Beam™ assembly at the tape locations. Maintain pressure for a minimum of 20 minutes to allow the tape to properly setup. This can be accomplished by wrapping the Mirror-Beam™/mirror assembly tightly with adhesive tape.

WARNING: The tape adhesive used in this procedure is fully bonded after 72 hours @ 70°F (21°C). During this period, do not expose the Mirror-Beam™ to any unnecessary force, such as the high-pressure water from a car wash.

- Locate the factory-drilled hole in the Mirror-Beam™ housing (Fig. 3). Using a 125" drill bit and the housing as a template, drill a hole into the mirror assembly. Using the #8 x 1/2" black oxide phillips truss screw, secure the Mirror-Beam™ housing to the mirror assembly.

Connecting the Mirror-Beam™ to Power:

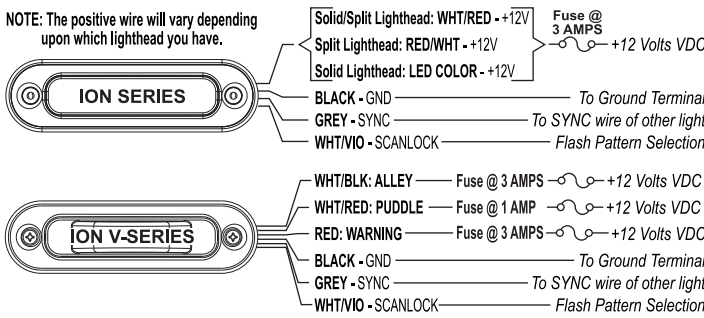

WARNING: All customer supplied wires that connect to the positive terminal of the battery must be sized to supply at least 125% of the maximum operating current and FUSED at the battery to carry that load. DO NOT USE CIRCUIT BREAKERS WITH THIS PRODUCT!

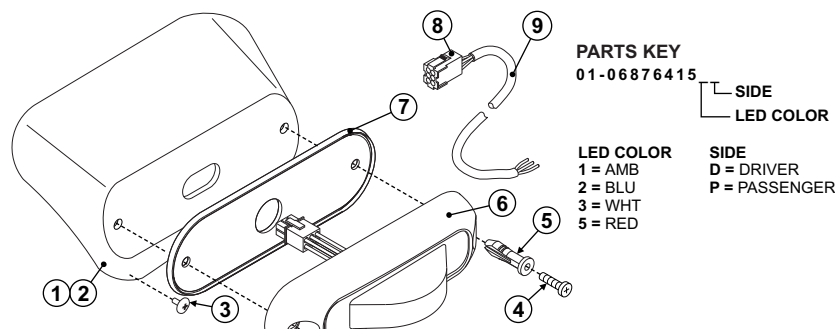

QTY	ITEM	PART NUMBER	DESCRIPTION
*		01-06876415__	MIRROR-BEAM ION V-SERIES 2015 TAHOE
A/R	1	11-487855-L00	HOUSING, MIRROR-BEAM DRIVER 2015 TAHOE
A/R	2	11-487855-R00	HOUSING, MIRROR-BEAM PASSENGER 2015 TAHOE
1	3	15-081C1B-081	SCREW, 8 X 1/2 PHIL TRUSS SS, BLACK OXIDE
2	4	15-081416-160	SCREW, 8 X 1 PPHSMS
2	5	21-1708080803	SCREW GROMET, #8 .250 DIA DOUBLE D
1	6	01-026E782-_0	SUB ASSY, SURFACE MOUNT ION V-SERIES
1	7	38-0444165-00	GASKET
1	8	01-0447089-00	KIT, CABLE INSTALLATION
1	9	46-0747089-15	ASSY, CABLE 3/C 18 GA 15'

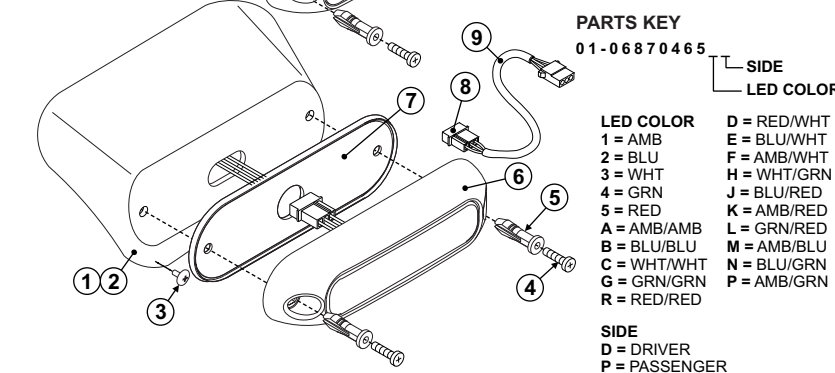

QTY	ITEM	PART NUMBER	DESCRIPTION
*		01-06870465__	MIRROR-BEAM ION 2015 TAHOE
A/R	1	11-487855-L00	HOUSING, MIRROR-BEAM DRIVER 2015 TAHOE
A/R	2	11-487855-R00	HOUSING, MIRROR-BEAM PASSENGER 2015 TAHOE
1	3	15-081C1B-081	SCREW, 8 X 1/2 PHIL TRUSS SS, BLACK OXIDE
2	4	15-081416-160	SCREW, 8 X 1 PPHSMS
2	5	21-1708080803	SCREW GROMET, #8 .250 DIA DOUBLE D
1	6	01-026D363-_0	SUB ASSY, SURFACE MOUNT ION
1	7	38-0444165-00	GASKET
1	8	01-0415532-00	KIT, CABLE INSTALLATION
1	9	46-0742172-15	ASSY, CABLE 3/C 18 GA 15'

- Route the Mirror-Beam™ cable through the door, along the same path as the vehicle's main power cable and connect to power.
- Cut the non-insulated wire off the Mirror-Beam™ cable (Not used). After the connections are complete, confirm proper operation.

Operation:

Scan-Lock™ (WHT/VIO) - NOTE: In order to change flash patterns, the light must be on.

To advance to the next flash pattern apply +VDC to the WHT/VIO wire for less than 1 second and release.

To cycle back to the previous pattern apply +VDC to the WHT/VIO wire for more than 1 second and release.

To reset the default pattern, when a pattern is displayed, allow it to run for over 5 seconds and the light will display this pattern when activated.

Flash Patterns:

- | | | | |
|------------------------|-----------------------|---------------------|----------------------|
| 1. SignalAlert™ 75PH 1 | 8. SingleFlash 75PH 2 | 15. SingleFlash 60 | 22. ActionFlash™ 150 |
| 2. SignalAlert 75PH 2 | 9. ComAlert™ 75PH 1 | 16. SingleFlash 90 | 23. ModuFlash™ |
| 3. CometFlash® 75PH 1 | 10. ComAlert 75PH 2 | 17. SingleFlash 120 | 24. ActionScan™ |
| 4. CometFlash 75PH 2 | 11. LongBurst™ 75PH 1 | 18. SingleFlash 300 | 25. Steady |
| 5. DoubleFlash 75PH 1 | 12. LongBurst 75PH 2 | 19. DoubleFlash 150 | |
| 6. DoubleFlash 75PH 2 | 13. PingPong™ 75PH 1 | 20. ComAlert™ 150 | |
| 7. SingleFlash 75PH 1 | 14. PingPong 75PH 2 | 21. ActionFlash™ 50 | |

BOLD = California Title XIII Compliant Pattern

Italic = SYNC Pattern PH 1 = Phase 1 PH 2 = Phase 2

SYNC (GREY) - Lights configured to display the Phase 1 mode of a pattern will flash simultaneously. Lights configured to display the Phase 2 mode will alternate with any Phase 1 lights with the same pattern.

To sync two lights, configure both lights to display the same Phase 1 pattern. With the power off, connect the GREY wires from each light together. When the lights are activated, their patterns will be synchronized. To configure the two lights to alternate their patterns, advance the pattern of either lights to Phase 2 of the current pattern.

IMPORTANT WARNING!

CAUTION! DO NOT LOOK DIRECTLY AT THESE LED'S WHILE THEY ARE ON. MOMENTARY BLINDNESS AND/OR EYE DAMAGE COULD RESULT!

IMPORTANT: It is the responsibility of the installation technician to make sure that the installation and operation of this product will not interfere with or compromise the operation or efficiency of any vehicle equipment!