

WHELEN[®]

ENGINEERING COMPANY INC.

51 Winthrop Road
Chester, Connecticut 06412-0684
Phone: (860) 526-9504
Fax: (860) 526-4078
Internet: www.whelen.com
Sales e-mail: autosale@whelen.com
Canadian Sales e-mail: canadiansales@whelen.com
Customer Service e-mail: custserv@whelen.com

Installation Guide: Liberty™ II ECE Mini-Lightbar

Warnings to Installers

Whelen's emergency vehicle warning devices must be properly mounted and wired in order to be effective and safe. Read and follow all of Whelen's written instructions when installing or using this device. Emergency vehicles are often operated under high speed stressful conditions which must be accounted for when installing all emergency warning devices. Controls should be placed within convenient reach of the operator so that they can operate the system without taking their eyes off the roadway. Emergency warning devices can require high electrical voltages and/or currents. Properly protect and use caution around live electrical connections. Grounding or shorting of electrical connections can cause high current arcing, which can cause personal injury and/or vehicle damage, including fire. Many electronic devices used in emergency vehicles can create or be affected by electromagnetic interference. Therefore, after installation of any electronic device it is necessary to test all electronic equipment simultaneously to insure that they operate free of interference from other components within the vehicle. Never power emergency warning equipment from the same circuit or share the same grounding circuit with radio communication equipment. All devices should be mounted in accordance with the manufacturer's instructions and securely fastened to vehicle elements of sufficient strength to withstand the forces applied to the device. Driver and/or passenger air bags (SRS) will affect the way equipment should be mounted. This device should be mounted by permanent installation and within the zones specified by the vehicle manufacturer, if any. Any device mounted in the deployment area of an air bag will damage or reduce the effectiveness of the air bag and may damage or dislodge the device. Installer must be sure that this device, its mounting hardware and electrical supply wiring does not interfere with the air bag or the SRS wiring or sensors. Mounting the unit inside the vehicle by a method other than permanent installation is not recommended as unit may become dislodged during swerving; sudden braking or collision. Failure to follow instructions can result in personal injury. Whelen assumes no liability for any loss resulting from the use of this warning device. PROPER INSTALLATION COMBINED WITH OPERATOR TRAINING IN THE PROPER USE OF EMERGENCY WARNING DEVICES IS ESSENTIAL TO INSURE THE SAFETY OF EMERGENCY PERSONNEL AND THE PUBLIC.

Warnings to Users

Whelen's emergency vehicle warning devices are intended to alert other operators and pedestrians to the presence and operation of emergency vehicles and personnel. However, the use of this or any other Whelen emergency warning device does not guarantee that you will have the right-of-way or that other drivers and pedestrians will properly heed an emergency warning signal. Never assume you have the right-of-way. It is your responsibility to proceed safely before entering an intersection, driving against traffic, responding at a high rate of speed, or walking on or around traffic lanes. Emergency vehicle warning devices should be tested on a daily basis to ensure that they operate properly. When in actual use, the operator must ensure that both visual and audible warnings are not blocked by vehicle components (i.e.: open trunks or compartment doors), people, vehicles, or other obstructions. It is the user's responsibility to understand and obey all laws regarding emergency warning devices. The user should be familiar with all applicable laws and regulations prior to the use of any emergency vehicle warning device. Whelen's audible warning devices are designed to project sound in a forward direction away from the vehicle occupants. However, because sustained periodic exposure to loud sounds can cause hearing loss, all audible warning devices should be installed and operated in accordance with the standards established by the National Fire Protection Association.

Safety First

This document provides all the necessary information to allow your Whelen product to be properly and safely installed. Before beginning the installation and/or operation of your new product, the installation technician and operator must read this manual completely. Important information is contained herein that could prevent serious injury or damage.

- **Proper installation of this product requires the installer to have a good understanding of automotive electronics, systems and procedures.**
- **Whelen Engineering requires the use of waterproof butt splices and/or connectors if that connector could be exposed to moisture.**
- **Failure to use specified installation parts and/or hardware will void the product warranty.**
- **If mounting this product requires drilling holes, the installer MUST be sure that no vehicle components or other vital parts could be damaged by the drilling process. Check both sides of the mounting surface before drilling begins. Also de-burr the holes and remove any metal shards or remnants. Install grommets into all wire passage holes.**
- **If this manual states that this product may be mounted with suction cups, magnets, tape or Velcro®, clean the mounting surface with a 50/50 mix of isopropyl alcohol and water and dry thoroughly.**
- **Do not install this product or route any wires in the deployment area of your air bag. Equipment mounted or located in the air bag deployment area will damage or reduce the effectiveness of the air bag, or become a projectile that could cause serious personal injury or death. Refer to your vehicle owner's manual for the air bag deployment area. The User/Installer assumes full responsibility to determine proper mounting location, based on providing ultimate safety to all passengers inside the vehicle.**
- **For this product to operate at optimum efficiency, a good electrical connection to chassis ground must be made. The recommended procedure requires the product ground wire to be connected directly to the NEGATIVE (-) battery post (this does not include products that use cigar power cords).**
- **If this product uses a remote device for activation or control, make sure that this device is located in an area that allows both the vehicle and the device to be operated safely in any driving condition.**
- **Do not attempt to activate or control this device in a hazardous driving situation.**
- **This product contains either strobe light(s), halogen light(s), high-intensity LEDs or a combination of these lights. Do not stare directly into these lights. Momentary blindness and/or eye damage could result.**
- **Use only soap and water to clean the outer lens. Use of other chemicals could result in premature lens cracking (crazing) and discoloration. Lenses in this condition have significantly reduced effectiveness and should be replaced immediately. Inspect and operate this product regularly to confirm its proper operation and mounting condition. Do not use a pressure washer to clean this product.**
- **It is recommended that these instructions be stored in a safe place and referred to when performing maintenance and/or reinstallation of this product.**
- **FAILURE TO FOLLOW THESE SAFETY PRECAUTIONS AND INSTRUCTIONS COULD RESULT IN DAMAGE TO THE PRODUCT OR VEHICLE AND/OR SERIOUS INJURY TO YOU AND YOUR PASSENGERS!**

IMPORTANT! The lightbar must be a minimum of 16" from any radio antennas.

NOTE: There may be a roof support member that spans the distance between the driver and passenger side. **DO NOT DRILL THROUGH THIS MEMBER!** Adjust the location until the holes can be drilled without contacting this support member.

Caution: Permanent mounting of this product will require drilling. It is absolutely necessary to make sure that no other vehicle components could be damaged by this process. Check both sides of the mounting surface before starting. If damage is likely, select a different mounting location.

Permanent Mounting:

1. Install the mounting bracket to the mounting foot using the supplied 5/16 FLAT WASHERS and 5/16 - 18 ELASTIC STOP NUTS (Fig. 1). Do NOT install the optional spacers yet.
2. Place the bracket into the track on the bottom of the extruded base of the lightbar and twist it into position (Fig. 2).

Fig. 1

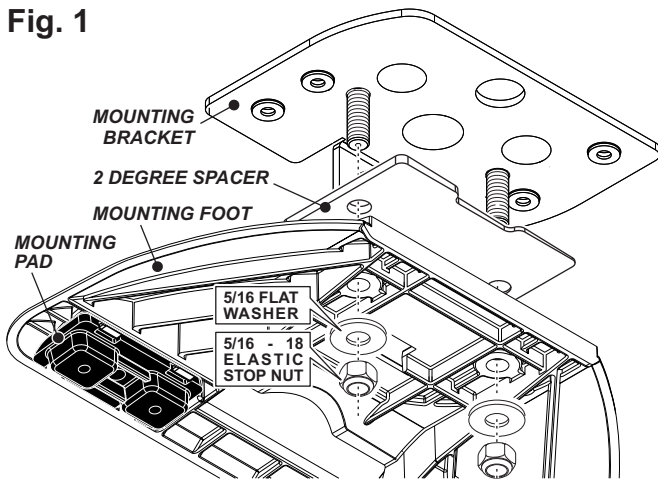

Insert round side of bracket under lip in extrusion

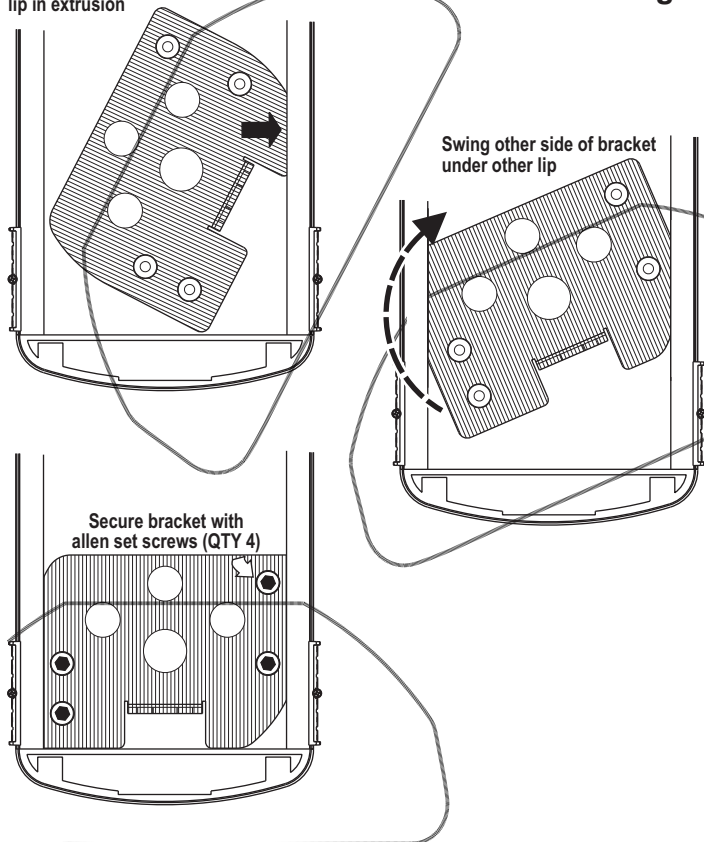
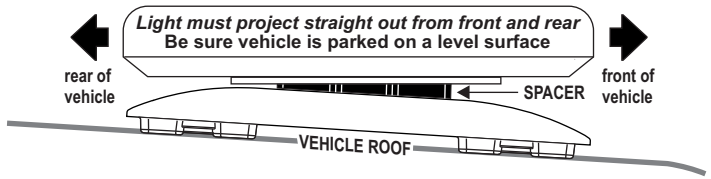
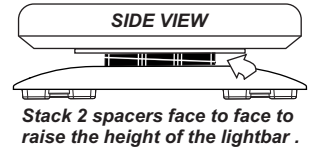

Fig. 2

3. Slide the bracket to the outer end of the base extrusion and secure the bracket to the extrusion using the four 1/4 - 20 X 1/2 ALLEN SET SCREWS (Fig. 2). Repeat steps 1 - 3 for other side of lightbar.
4. **Installing Spacers:** Spacers are used as required to adjust the lightbars clearance from the vehicle roof. Spacers are also used to make the lightbar level with the road so that the light does not project up or down when viewed from the front or rear of the vehicle. Each spacer creates a 2° incline.



Lightbar angle: Place the lightbar onto the vehicle roof in its exact mounting location and use a level to check the angle of the lightbar. If (because of the curvature of the vehicle roof) the front and rear lights project up or down, you will need to install one of the supplied spacers. Note the angle of the tilt to determine where to place the spacer.



Installation: Remove the mounting feet (not the bracket) and install the spacer (maximum 1 per side) then reinstall the feet.

Distance from roof: The lightbar must be no closer than 1/2 inch (at the closest point) from the vehicle roof. **Installation:** Remove the mounting feet (not the bracket), install the spacers as shown (maximum 2 per side) and reinstall feet.

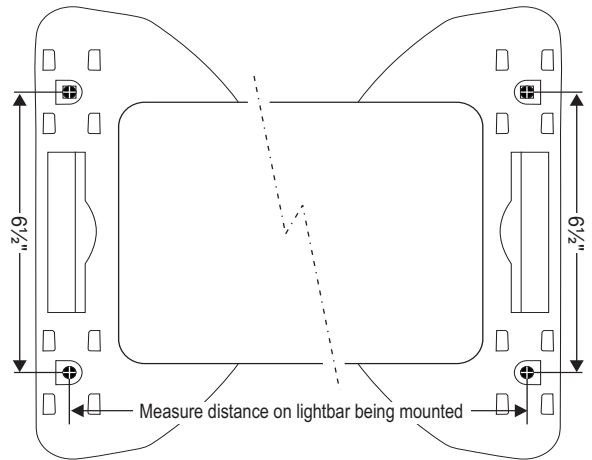

5. Position the lightbar onto the vehicle in its exact mounting location and mark the location of the mounting holes onto the mounting surface using the mounting feet as templates.

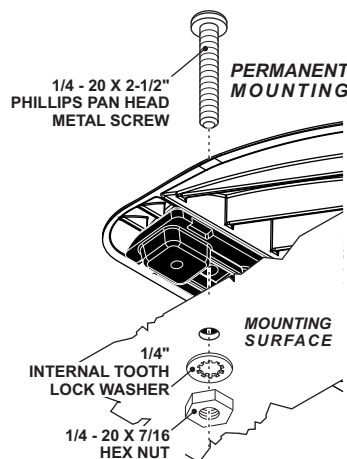

If the permanent mounting holes in the mounting feet are difficult to access, you can use the measurements shown here to mark off and drill the mounting holes. You will also need to measure the distance between the mounting feet for your application since lightbar width will depend on the lightbar you are mounting.

6. Remove the lightbar and drill the 4 mounting holes.
7. Install the lightbar using the supplied 1/4 - 20 Phillips Pan Head Metal Screw, 1/4" Internal Tooth Lock Washer and 1/4 - 20 X 7/16 Hex Nut.

Fig. 1

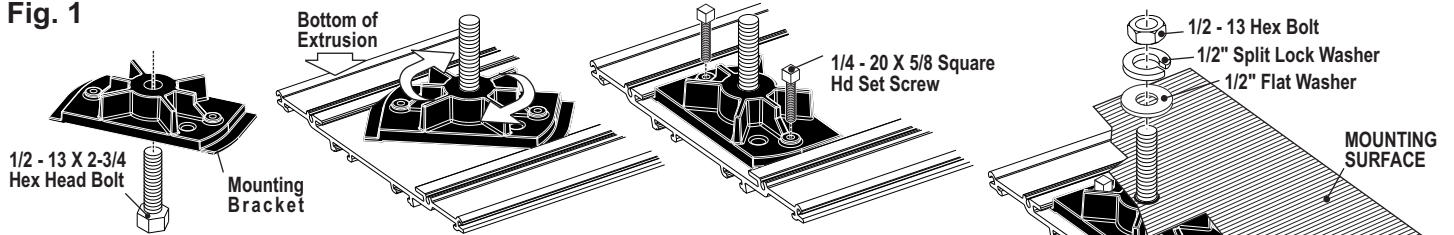

IMPORTANT! The lightbar should be located a minimum of 16" from any radio antennas!

Slide Bolt Mounting:

1. Insert the two supplied 1/2 - 13 X 2-3/4 HEX HD BOLTS into the slide bolt brackets and twist the two brackets into the bottom of the lightbar extrusion (Fig. 1).
2. With the slide bolt brackets in their mounting position, secure them to the lightbar with the supplied set screws.
3. Position the lightbar onto the vehicle and mark the location of the two mounting bolts off onto the mounting surface.
4. Remove the lightbar and drill the two mounting holes you marked off using a 1/2" drill bit.
5. Secure the lightbar to the mounting surface with the supplied mounting hardware.
6. Extend wires to your switch panel and refer to the wiring diagram. Refer to the instructions included with your switches for switch wiring.

Temporary Magnetic/Suction Cup Mounting:

The magnetic/suction cup should be mounted on a flat part of the roof.

Magnetic/suction: Thoroughly clean the proposed mounting surface prior to mounting. Wipe the suction cup clean, place the beacon onto its mounting surface and apply gentle pressure to ensure a good seal has been achieved.

WARNING! The use of any magnetically mounted warning device on the outside of a vehicle in motion is not recommended and is the sole risk and responsibility of the user.

IMPORTANT! It is the responsibility of the installation technician to make sure that the installation and operation of this product will not interfere with or compromise the operation or efficiency of any vehicle equipment! Before returning the vehicle to active service, visually confirm the proper operation of this product, as well as all vehicle components/equipment.

Wiring and Operation:

Extend the control cable to your switch panel and make connections. The control cable connects to your control head or switch box and is fused there. Applying +12VDC to a control wire will activate its function. BLACK and WHT/BLK are ground wires. (Optional Alley/Take-down cable also shown).

Cigar Plug: In models that feature a cigar plug, you can control Scan-Lock pattern selection and Power with the 2 switches located on the top of the plug.

(Optional Alley/Take-down cable not included with standard model also shown).

Cigar Cord Switch

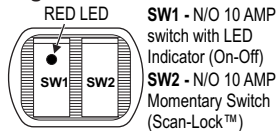

BROWN / Low Power:

The switch type used depends on how you wish Low Power to function:

Latching Mode: Apply +12 VDC to the BROWN wire for less than 1 sec. to "latch" the lightbar into Low Power. The unit must be turned off and then back on to restore normal operation. (Momentary Switch)

Level Mode: Apply +12 VDC to the BROWN wire for over 1 sec. to hold the lightbar in Low Power until voltage is removed. (Toggle Switch)

WHITE-GREEN / Scan-Lock™:

The WHT/GRN wire allows you to choose from available flash patterns. You must activate the function to select a pattern:

TO CYCLE THROUGH ALL PATTERNS:

To cycle forward apply +12 VDC to the WHT/GRN wire for less than 1 second and release.

To cycle backward apply +12 VDC to the WHT/GRN wire for more than 1 second and release.

TO SET A PATTERN AS DEFAULT:

When the pattern is displayed, allow it to run for more than 5 seconds. The lighthead will now display this pattern when activated.

TO RESET TO THE FACTORY DEFAULT PATTERN:

With power off, apply +12 VDC to WHT/GRN wire while turning power on.

Use a normally open momentary switch for Scan-Lock operation

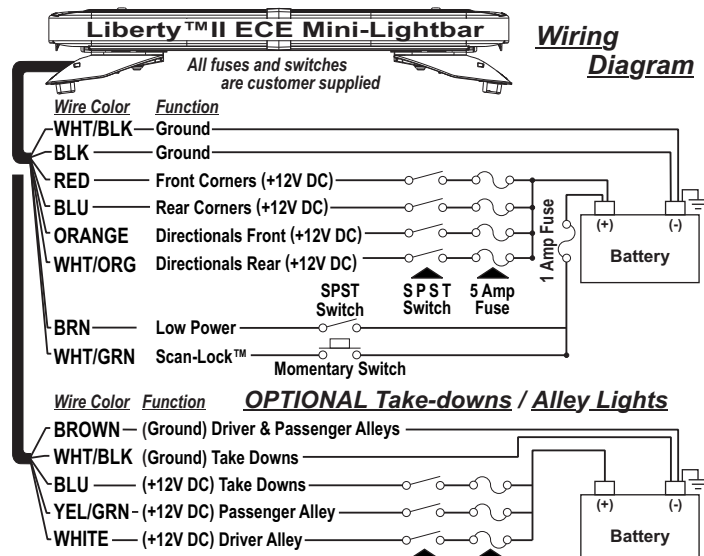

RED /

Front Corners:

Apply +12VDC to the RED wire to activate the Front Corner lights.

BLUE / Rear Corners

Apply +12VDC to the BLUE wire to activate the Rear Corner lights.

ORANGE / Front Directionals:

Apply +12VDC to ORG wire to activate the Front Directional lights.

WHT/ORG / Rear Directionals:

Apply +12VDC to WHT/ORG wire to activate the Rear Directional lights.

- | | | |
|------------------------------|-------------------------------|-------------------------------|
| 1. DoubleFlash 125 (ECE) (D) | 21. SingleFlash 75 SIM | 41. SingleFlash 120 SIM |
| 2. SingleFlash 125 (ECE) | 22. SingleFlash 75ALT/SIM | 42. SingleFlash 120 ALT/SIM |
| 3. SignalAlert™ L/R SYNC | 23. LongBurst™ L/R SYNC | 43. SingleFlash 240 L/R SYNC |
| 4. SignalAlert™ L/R ASYNC | 24. LongBurst™ L/R ASYNC | 44. SingleFlash 240 L/R ASYNC |
| 5. SignalAlert™ IN/OUT | 25. LongBurst™ IN/OUT | 45. SingleFlash 240 IN/OUT |
| 6. SignalAlert™ SIM | 26. LongBurst™ SIM | 46. SingleFlash 240 SIM |
| 7. SignalAlert™ ALT/SIM | 27. LongBurst™ ALT/SIM | 47. SingleFlash 240 |
| 8. CometFlash® L/R SYNC | 28. SingleFlash 60 L/R SYNC | 48. ActionFlash™ L/R SYNC |
| 9. CometFlash® L/R ASYNC | 29. SingleFlash 60 L/R ASYNC | 49. ActionFlash™ L/R ASYNC |
| 10. CometFlash® IN/OUT | 30. SingleFlash 60 IN/OUT | 50. ActionFlash™ IN/OUT |
| 11. CometFlash® SIM | 31. SingleFlash 60 SIM | 51. ActionFlash™ SIM |
| 12. CometFlash® ALT/SIM | 32. SingleFlash 60 ALT/SIM | 52. PingPong™ L/R SYNC |
| 13. DoubleFlash 75 L/R SYNC | 33. SingleFlash 90 L/R SYNC | 53. PingPong™ L/R ASYNC |
| 14. DoubleFlash 75 L/R ASYNC | 34. SingleFlash 90 L/R ASYNC | 54. PingPong™ IN/OUT |
| 15. DoubleFlash 75 IN/OUT | 35. SingleFlash 90 IN/OUT | 55. PingPong™ SIM |
| 16. DoubleFlash 75 SIM | 36. SingleFlash 90 SIM | 56. ModuFlash™ L/R SYNC |
| 17. DoubleFlash 75 ALT/SIM | 37. SingleFlash 90 ALT/SIM | 57. ModuFlash™ L/R ASYNC |
| 18. SingleFlash 75 L/R SYNC | 38. SingleFlash 120 L/R SYNC | 58. ModuFlash™ IN/OUT |
| 19. SingleFlash 75 L/R ASYNC | 39. SingleFlash 120 L/R ASYNC | 59. ModuFlash™ SIM |
| 20. SingleFlash 75 IN/OUT | 40. SingleFlash 120 IN/OUT | 60. ActionScan™ |

IMPORTANT: Only flash patterns 1 and 2 are ECE compliant.

L/R - SYNC: LEFT / RIGHT SYNCHRONOUS **L/R - ASYNC:** LEFT / RIGHT ASYNCHRONOUS
IN / OUT: IN / OUT **SIM:** SIMULTANEOUS **ALT/SIM:** ALTERNATING SIMULTANEOUS
(D) = Default Flash Pattern

QTY	QTY	QTY	QTY	QTY	QTY	QTY	ITEM	PART NUMBER	DESCRIPTION
						*		01-0688186-___	LIBERTY II ECE MINI LIGHTBAR, BLUE, PERM MT
						*		01-0688186-___	LIBERTY II ECE MINI LIGHTBAR, BLUE, MAG MT
						*		01-0688186-___	LIBERTY II ECE MINI LIGHTBAR, BLUE, VACUUM MT
						*		01-0688186-___	LIBERTY II ECE MINI LIGHTBAR, AMBER, PERM MT
						*		01-0688186-___	LIBERTY II ECE MINI LIGHTBAR, AMBER, MAGMT
						*		01-0688186-___	LIBERTY II ECE MINI LIGHTBAR, AMBER, VACUUM MT
1	1	1	1	1	1	1	1	11-36F309-015	BASE, EXTRUDED MACHINED 15.72" LEGACY MINI
1	1	1	1	1	1	1	2	21-11245004-1	GROMMET, SPECIAL TO BE MOLDED 1.562"
1	1	1	1	1	1	1	3	14-0023347-01	SCREW, 10-24 X .875" TX PHD SWEDGE FORM 1/4" LEAD 5/8" THD
2	2	2	2	2	2	2	4	07-26E120-000	BRCKT, BULKHEAD LENS MOUNT LIBERTY II
1	1	1	1	1	1	1	5	07-26D865-000	BRACKET, I/O ANCHOR LEGACY LIGHTBAR
-	-	1	-	-	-	1	6	02-0168H001-02	I/O BD MINI SOLO 12V ENHANCED ECE STANDARD
-	-	1	-	-	-	1	7	46-0743403-00	CABLE 9/C 18 GA TPR 20' SL-156 SCKTS 1 END
1	1	-	1	1	-	-	8	02-0243700-03	ASSY, CIGAR CORD WITH 8 POS SL-156
-	-	1	-	-	-	1	9	26-0115037-06	CABLE CLAMP, 3/8"D, 1/2"W, .203" MTG HOLE, BLACK
1	1	-	1	1	-	-	10	26-0115037-04	CABLE CLAMP, 1/4"D, 3/8"W, .203" MTG HOLE, BLACK
1	1	1	1	1	1	1	11	13-104111-063	NUT, 10-24 CAD PLATED WHIZ OR STEEL ZINC PLATED
1	1	1	1	1	1	1	12	26-0215001-06	TY WRAP, 6" BLACK
-	-	1	-	-	-	1	13	39-1M17672-08	HSNG, PLUG 8 POS 18 AWG SL-156 W/ LOCK, RAMP
2	2	2	2	2	2	2	14	07-247187-000	BRACKET, END CLAMP NO ALLEY LIBERTY II
10	10	10	10	10	10	10	15	14-062216-081	SCREW, 6-32 X 1/2 PPHMS SEMS WIT LOCK WSHR 410 SS
-	-	A/R	-	-	A/R	16	01-0247193-30	SUB ASSY, 3LED TIR ALLEY LIGHT LIBERTY II	
-	-	-	2	2	2	17	01-026F608-29	CORNER L-FRT/R-REAR BLU, SINGLE ROW LIBERTY II	
-	-	-	2	2	2	18	01-026F609-29	CORNER L-REAR/R-FRT BLU, SINGLE ROW LIBERTY II	
-	-	-	OPT	OPT	OPT	19	68-396F577-2E	LENS, ECE BLU CORNER FILT NON OPTIC LIBERTY II	
2	2	2	-	-	-	20	01-026G304-10	CORNER L-FRONT/R-REAR AMB ECE LIBERTY II	
2	2	2	-	-	-	21	01-026G305-10	ASSY,CORNER L-REAR/R-FRONT AMB ECE LIBERTY II	
4	4	4	-	-	-	22	68-196F577-30	LENS, CLEAR CORNER FILTER OPTIC LIBERTY II	
OPT	OPT	OPT	-	-	-	23	68-196F577-10	LENS, AMBER CORNER FILTER OPTIC LIBERTY II	
4	4	4	4	4	4	24	07-226275-000	BRACKET, CORNER CLAMP LIBRTY II	
-	-	-	4	4	4	25	01-0247106-20	SUB ASY, SHORT DIRECT BLU LIBRTY II 1 COLOR	
4	4	4	4	4	4	26	01-0247501-10	SUB ASSY,SHORT DIRECT AMB ECE LIBRTY II 1 COLOR	
4	4	4	4	4	4	27	68-1947100-30	LENS, CLR 1/2 FILT. OPTIC REFLECT LIBTY II	
-	-	-	OPT	OPT	OPT	28	68-1947100-2E	LENS, ECE BLU 1/2 FILT. OPT REFLECT LIBRTY II	
OPT	OPT	OPT	-	-	-	29	68-1947100-10	LENS, AMB 1/2 FILTER OPT REFLECT LIBRTY II	
-	-	A/R	-	-	A/R	30	01-0247225-30	SUB ASSY, 3LED 1/2 TAKE-DOWN LIBERTY II	
-	-	A/R	-	-	A/R	31	01-026E778-30	SUB ASSY, 1/2 TIR TAKE-DOWN LIBERTY II	
2	2	2	2	2	2	32	07-223841-000	BRACKET, FILLER LEGACY LTBAR	
1	1	1	1	1	1	33	46-0787707-00	ASSY, HARNESS J1 MINI LEGACY	
1	1	1	1	1	1	34	46-0787707-01	ASSY, HARNESS J6 MINI LEGACY	
1	1	1	1	1	1	35	46-0787707-02	ASSY, HARNESS J2 MINI LEGACY	
1	1	1	1	1	1	36	46-0787707-03	ASSY, HARNESS J5 MINI LEGACY	

-	-	A/R	-	-	A/R	37	39-0402023-04	HOUS, 2 POS SOC COMM MAT-N-LOK
-	-	A/R	-	-	A/R	38	39-0403023-04	HOUS, 3 POS SOC COMM MATE-N-LOK
-	-	A/R	-	-	A/R	39	46-0787732-01	LEGACY MINI, ALLEY HARNESS
-	-	A/R	-	-	A/R	40	46-0787732-00	LEGACY MINI TAKEDOWN HARNESS
-	-	A/R	-	-	A/R	41	46-0742938-07	CABLE 5/C 18 GA TPR 20' CMNL SKT 1 END
4	4	4	4	4	4	42	07-26F382-000	BRACKET, SNAP-IN LT MODULE MT
A/R	A/R	A/R	A/R	A/R	A/R	43	26-0215001-03	TY WRAP, 3" BLACK
2	2	2	2	2	2	44	02-036E7742**	SUB ASSY, CUT DOME, MINI LIB. II
2	2	2	2	2	2	45	38-046E119-00	SEAL, LENS DIVIDER LIBERTY II
1	1	1	1	1	1	46	38-046E118-00	DIVIDER, LENS LIBERTY II
4	4	4	4	4	4	47	14-104286-16J	SCREW, 10-24 X 1.25" WAX DIP SHLDR PHTX TRI PT SS
1	1	1	1	1	1	48	66-0917786-00	WIPE, STENCIL ALCOHOL REFILL CE# 440-594
4	4	4	4	4	4	49	66-0444378-00	TAPE, VHB ENDCAP TRIM MT LEGACY LTBAR
2	2	2	2	2	2	50	11-26F536-007	CVR, TOP EXTRUD 7.325" MINI LEGACY
4	4	4	4	4	4	51	15-105C76-148	SCREW, 10 X 7/8 T-25 TORX TRUSS HD PLAST,LOC SS WIN/SEAL
-	-	1	-	-	1	52	02-0487333-07	LOW PROFILE MTG FOOT PERM MT
-	2	-	2	-	2	53	02-036A935-00	SUB ASSY, MAGNET MT JUSTICE MINI
2	-	-	2	-	-	54	14-130436-120	SCREW, 1/4-20 X 3/4" HEX HD MS SS
2	-	-	2	-	-	55	16-1302820-06	WSHR, FLAT 1/4" 7/8 OD SS 17/64 ID .056-.070" THK
2	-	-	2	-	-	56	08-1583927-05	SUCTION CUP, MAGNET MOUNT
4	-	-	4	-	-	57	14-130526-08M	SCREW, 1/4-20 X 1/2 SET ALLEN SKT HD CUP PT STEEL BK W/PATCH
2	-	-	2	-	-	58	07-764726-023	PLATE, ADAPT MAG/SUC CUP MINI LTBAR
-	-	A/R	-	-	A/R	59	02-038132309S	ASSY, 1/2" MTG BRACKET SLIDE BOLT
1	1	1	1	1	1	63	02-016H001-03	I/O BOARD MINI SOLO 12V ENHANCED ECE CIGAR

MOUNTING OPTIONS

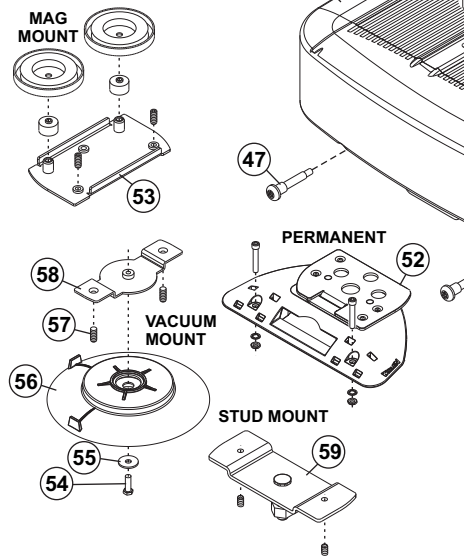

LIGHTHEAD OPTIONS

