

WHELEN[®]

ENGINEERING COMPANY INC.

51 Winthrop Road
Chester, Connecticut 06412-0684
Phone: (860) 526-9504
Fax: (860) 526-2009
Internet: www.whelen.com
Sales/Service e-mail: aviation@whelen.com

Installation Guide/ICA:
Model OR36S2W, OR36S2WL
P/N:01-0772010-32
01-0772010-33
LED Anti-Collision Light Assembly

TSO-C96a
CLASS III;
APPROVED



The conditions and tests required for TSO approval of this article are minimum performance standards. Those installing this article either on or within a specific type or class of aircraft must determine that the aircraft installation conditions are within the TSO standards which include any accepted integrated non-TSO functions. TSO articles and any accepted integrated non-TSO function(s) must have separate approval for installation in an aircraft. The article may be installed only according to 14 CFR part 43 or the applicable airworthiness requirements.

OPERATING INSTRUCTIONS:

Operational Voltage: 28 VDC
Average Input Current: 0.26 Amps
Pulse : 1.4 Amps
Flashrate: 45± 4 FPM
Weight: 0.37 lbs. (ref.)

EQUIPMENT LIMITATIONS: An approved Anti-Collision light assembly should be located so that their light will not impair the crews vision or detract from the conspicuity of the position lights. The baseplate must be mounted parallel to the vertical and horizontal centerlines of the aircraft to project the patterns properly.

Certain types of installations may require additional testing.

AIRWORTHINESS LIMITATIONS:

The Airworthiness Limitations section is FAA approved and specifies inspections and other maintenance required under §43.16 and §91.403 of the Federal Aviation Regulations, unless an alternative program has been approved.

No airworthiness limitations are associated with the installation of the LED anti-collision light.

CONTINUED AIRWORTHINESS:

Model OR36S2W and OR36S2WL are designed with 10 red LEDs and 8 white LEDs. If any one LED fails the unit must be repaired or replaced.

Note: To reduce eye strain, use an optical filter such as dark glasses or a blue covering dome during LED inspection.

Inspect the lens. Replace if there is excessive surface deterioration, discoloration, crazing or cracking. For additional lens maintenance detail, see SAE ARP5637.

PERIODIC INSPECTIONS: An annual inspection shall be performed unless the OEM specifies a shorter interval.

INSTALLATION PROCEDURES: The following information provides guidelines for the installation of the Whelen LED anti-collision light. Please refer to the OEM manual for your aircraft for specific removal and installation instructions.

1. Remove all electrical power or disable the applicable circuit breakers.
2. Using the mounting detail information provided, prepare the aircraft for means to secure the LED light assembly.
3. Connect the light inputs according to the chart shown. Connect the power lead to an appropriately sized breaker. Connections to be in accordance with FAA approved methods.
4. Using the appropriate hardware install the light assembly to the aircraft. Insure that all leads are clear of any obstructions and secured as required.
5. Enable applicable circuit breakers, place lighting switch in the ON position and verify proper operation of the Whelen lights.
6. Check all avionics systems for interference from this installation.
7. A flight check should be performed by a properly certified pilot.
8. If required, update aircraft records utilizing FAA Field Approval (Form 337) or equivalent.

Aviation

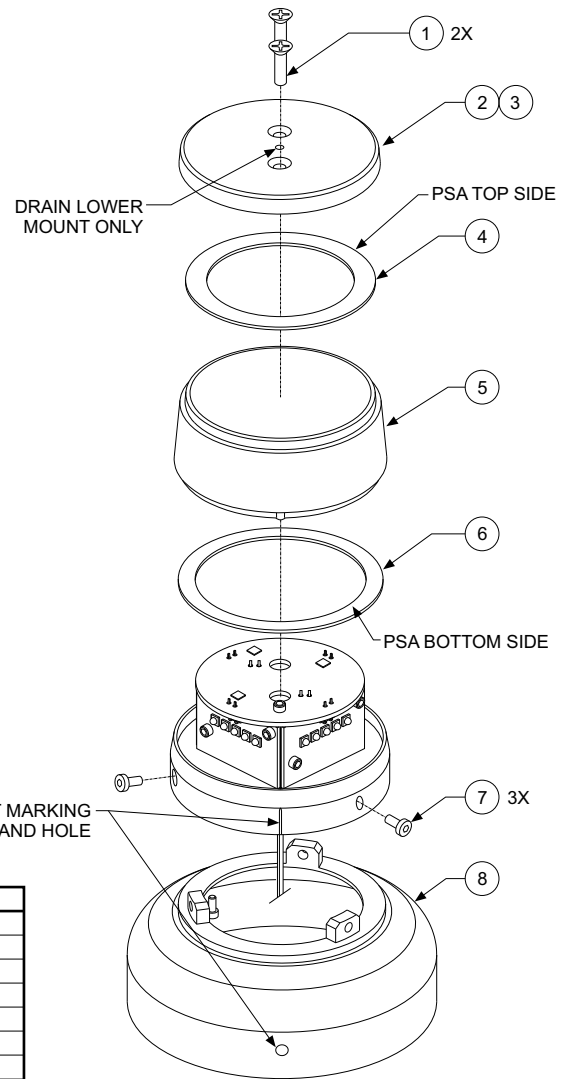
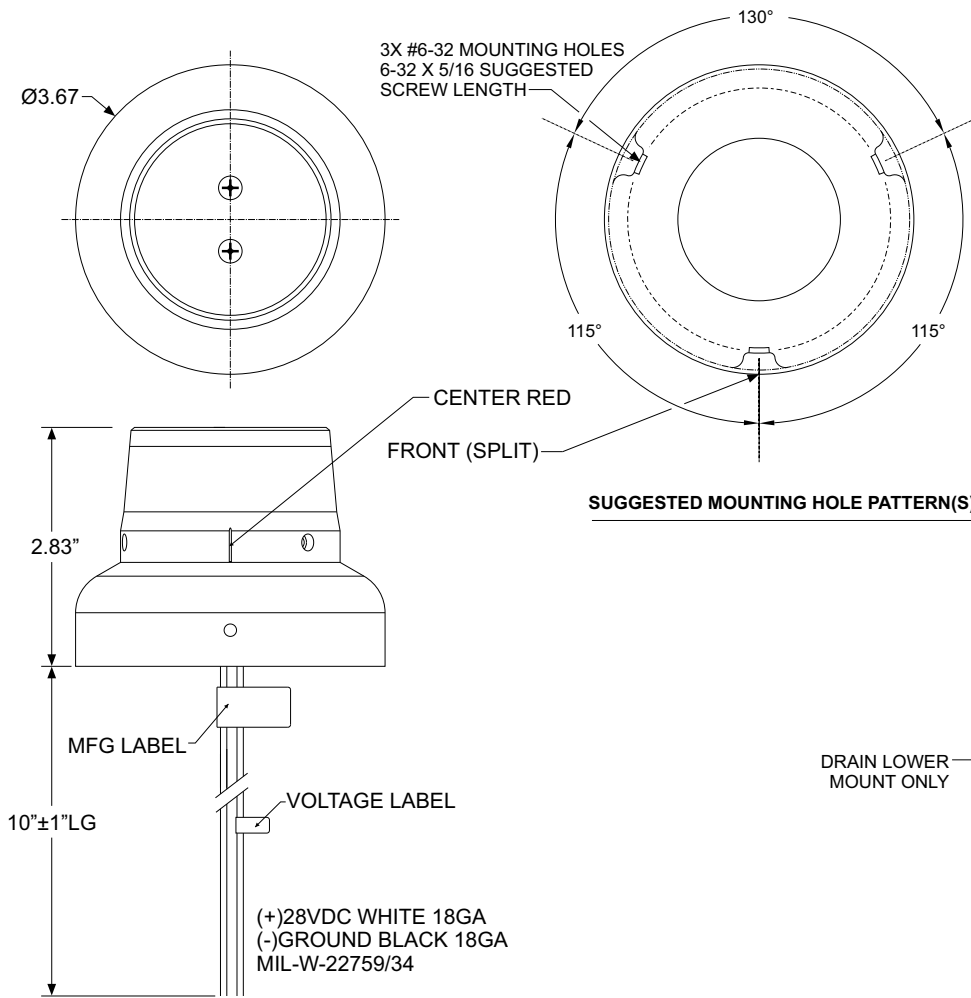

CAUTION! Do not touch the LEDs with either fingers or sharp objects. This could soil or damage the LEDs and effect the optical performance of the light.

QTY	QTY	ITEM	PART NUMBER	DESCRIPTION
*	*		01-0772010-32	MODEL, OR36S2W 28V UPPER SPLIT 3.7" ACL
*	*		01-0772010-33	MODEL, OR36S2WL 28V LOWER SPLIT 3.7" ACL
2	2	1	MS24693C28	SCREW, 6-32 X 1/2 P100FH/CSNK
1	-	2	22-0472012-01	CAP, LED A/C BEACON W/ DRAIN
-	1	3	22-0472012-00	CAP, LED A/C BEACON
1	1	4	38-0231522-01	GASKET, LENS UPPER 72010 BEACON
1	1	5	68-1972008A30	LENS, CLEAR OPTIC LED A/C BEACON HARD COAT
1	1	6	38-0231523-00	GASKET, LENS LOWER 72010 BEACON
3	3	7	14-040A20-05K	SCREW, 4-40 X 5/16" ALLEN SOCKET HD CAP
1	1	8	07-572032-100	PLATE, ADAPTER SIDE MOUNTING 72010 BEACON