

1200D Series

SELF-CONTAINED STROBE BEACON



The original Whelen 1200 Strobe beacon, introduced in 1968, pioneered a new standard in automotive warning.



FEATURES

- High-gain, self-cleaning, aerodynamic high profile dome.
- 36 watt input/25 watt output.
- Choice of four flash patterns standard in every model: CometFlash®, DoubleFlash, RapidRate™ and ActionFlash™.
- Built-in exclusive Photo Sensor (selectable use) via automatic intensity control or automatic On/Off operation.
- Manual Hi/Low intensity control via external switch.
- AMECA Certified to S.A.E. and California Title XIII requirements.
- 25 watts output power.
- Double fresnel optic lens provides excellent 360° light dispersion.
- High profile, 8-1/2" tall.
- Dual voltage 12/24VDC power supply, includes circuits that protect against reverse polarity damage and flash tube ionization.
- Patented clamp circuit prevents power supply damage in the event of flash tube failure.
- Polished, cast aluminum base offers permanent and 1" NPT pipe mounting.
- Five year, HDP® Heavy-Duty Professional Warranty on power supply; two year warranty on Gold Medallion flash tube.



WHELEN®

1200D Series Specifications

Shatterproof, polycarbonate lens with double fresnel optic design, provides excellent 360° light dispersion.

1200D Series Strobe Beacons are modular and easily field serviced via Amp Mate-N-Lok® connectors (no cutting of wires), minimizing equipment downtime.

Three pin, plug-in flash tube assembly is secured in place with two retaining screws for added vibration resistance.

Fully enclosed, polished cast aluminum base for heavy-duty applications, offers choice of permanent and 1" NPT pipe mounting.

Easy to install with a two wire connection, 1200D Series strobe beacons are shipped preset for the CometFlash flash pattern and high intensity operation.

"Heavy-duty" silicone potted circuit boards maximize vibration and moisture resistance while allowing for the units to be economically repaired.

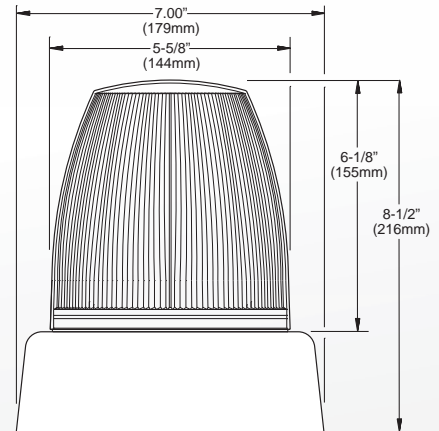

MODELS

1200DH*P High Dome, Permanent/Pipe Mount

Due to variations in vehicle surfaces and operating conditions, the use of any magnetic mount warning beacon on the vehicle while in motion is at the discretion and risk of the user.

OPTIONS

HGDOMEH* .. High Gain Dome for 1200 Series

80DTUBE 1200D Series Helix 1-1/2 Turn, 3 Pin Plug-In Base Strobe Tube

* Replace symbol in model number with letter indicating lens color desired:

A=Amber; B=Blue; R=Red (Not available in Clear or Green, consider an LED Beacon).

GENERAL ELECTRICAL AND PHYSICAL DATA

Input Voltage: 12 VDC and 24 VDC
 Input Current: 2.5 amps @12.8V/1.5 amps @25.6V
 Input Power: 36 Watts
 Output Power: 25 Watts
 Output Energy: 18.5 joules, 9.5/3/3/3 joules¹
 Effective Candle Power: Approx. 650 Candella
 Flashrate: CometFlash® 80 FPM
 DoubleFlash 115 FPM
 RapidRate™ 185 FPM
 ActionFlash™ 1 CF - 4 RRF²
 Operating Temperature: -30°F (-34°C) to +120°F (49°C)
 Weight: 3 lbs. 5 oz. (1.58 kg)

1. CometFlash Pattern.

2. ActionFlash is a combination pattern that repeats one CometFlash and four RapidRate Flashes.



WHELEN®
 ENGINEERING COMPANY, INC.

51 Winthrop Road
 Chester, Connecticut 06412-0684
 (860) 526-9504 • Fax: (860) 526-4078
 www.whelen.com

Whelen Engineering reserves the right to upgrade and improve products without notice.
 © 2011 Whelen Engineering Company, Inc. Printed in U.S.A.
 NASCAR® is a registered trademark of the National Association for Stock Car Auto Racing, Inc.
 Code No. 10503F - 052311

American Employees, American Manufacturing, American Pride!