

# 2519 Series Encapsulated Strobe Beacons

BEACON

Fully encapsulated electronics are impervious to damage from moisture and vibration.



Diagnostix™

2519LPA

2519HPA

2519LPA



## FEATURES

- Fully encapsulated electronics are moisture and vibration resistant.
- Built-in LED diagnostic indicator displays the operational state of electronic power supply and flash tube.
- Automatic Photocell Hi/Low can be overridden to maintain high intensity during nighttime operation.
- Combination mounting: permanent mount, and pipe/flat/"J" hook mount.
- Magnetic mount and magnetic/suction models are CometFlash® and high power only and do not offer Scan-Lock™, cruise light, low power or SYNC functions. Supplied with 8' cord and cigar plug.
- 7 Scan-Lock flash patterns. CometFlash is factory supplied default flash pattern.
- Simple to replace flash tube.
- Operating temperature -31° to +149°F (-35°C to +65°C).
- Polycarbonate base.
- Class 1 SAE Certified, (amber); Class 2 (all other colors).
- 12/24 VDC.
- Input power: 27 watts.
- Output power: 19 watts; 16 joules. Input current: 2.1 amps/12 VDC; 1.1 amps/24 VDC.



**WHELEN®**

# 2519 Series Specifications

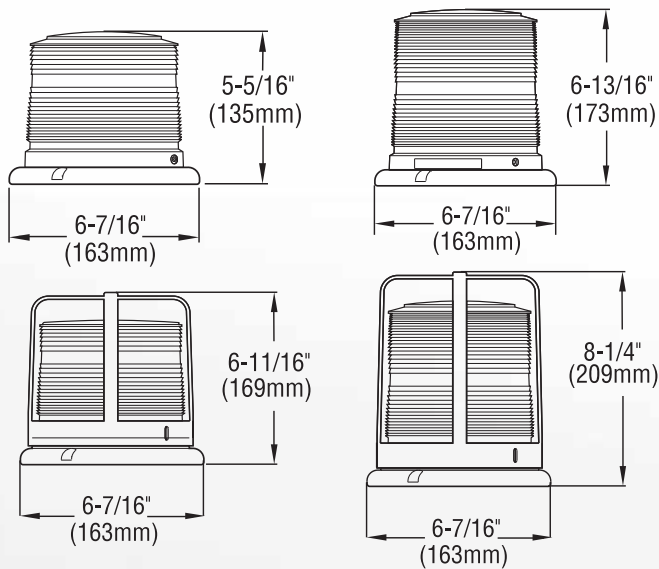

## MOUNTING

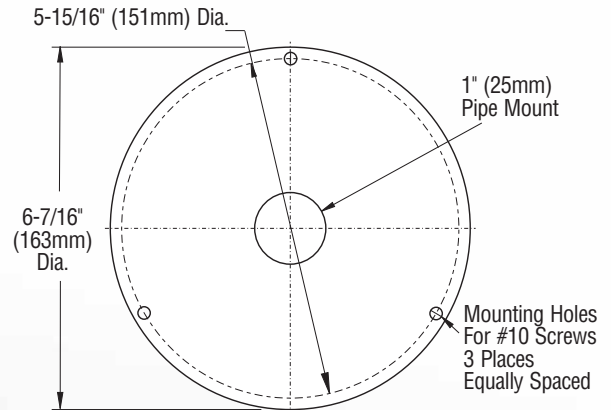

## MODELS

2519 Series with polycarbonate base, encapsulated, 7 Scan-Lock™ flash patterns, photocell Hi/Low with Hi Power Override, magnetic mount with CometFlash® and Hi Power only.

Model	Description
2519LP*	Perm/pipe/"J" hook mount, low dome
2519HP*	Perm/pipe/"J" hook mount, high dome
2519LP*M	Magnetic mount, low dome
2519HP*M	Magnetic mount, high dome
2519LP*V	Vacuum suction/cup mount, low dome
2519HP*V	Vacuum suction/cup mount, high dome

\* Replace asterisk in model numbers with desired color.  
A = Amber, B = Blue, C = Clear, G = Green, R = Red



BBKT20 flat vertical surface mounting bracket

## FLASH PATTERNS

CometFlash	70 FPM (Default pattern)
TripleFlash™	80 FPM
DoubleFlash	90 FPM
SingleFlash	120 FPM
ModuFlash™	60-120-60 FPM
ActionFlash™	Comet-Single
ScanFlash™	Comet-Single-Triple-Single-Double-Single-Repeat

## OPTIONS

MMK	90 lb. pull magnet mt. kit with 8 ft. cord & plug
BGL	Branch guard, low dome
BGH	Branch guard, high dome
LSK	Lighted switch kit
MIRROR20	West Coast mirror mount bracket
BBKT20	Stainless steel shelf mount bracket mounts to flat vertical surface

## REPLACEMENT PARTS

DH2000*	High Dome
DL2000*	Low Dome
FT25	Flash Tube

Note: The use of any magnetic mounted warning beacon on the vehicle while in motion, is at the discretion and risk of the user.

# WHELEN®

ENGINEERING COMPANY, INC.

51 Winthrop Road  
Chester, Connecticut 06412-0684  
(860) 526-9504 • Fax: (860) 526-4078  
www.whelen.com

Whelen Engineering reserves the right to upgrade and improve products without notice.  
© 2010 Whelen Engineering Company, Inc. Printed in U.S.A.  
NASCAR® is a registered trademark of the National Association of Stock Car Auto Racing, Inc.  
Code No. 11670D - 05/10

American Employees, American Manufacturing, American Pride!