

# Super Strobe® S360D Series

## SELF-CONTAINED STROBE BEACON

BEACONS

Premium quality Super Strobe leads the industry as the most effective, high intensity strobe warning beacon.



### FEATURES

- Choice of four flash patterns standard in every model: CometFlash®, DoubleFlash®, Rapid Random Flash™ and ActionFlash™.
- CROSS-LINK strobe synchronization allows up to four S360D beacons to flash in simultaneous or alternating pattern to work as one system.
- Manual High/Low intensity control via external switch.
- AMECA Certified to S.A.E. and California Title XIII requirements.
- Powerful warning with full 30 watts output power.
- Superior visibility. Patented, optic design delivers full illumination of lens area and uniform 360° light dispersion.
- Dual voltage 12/24VDC power supply includes circuits that protect against reverse polarity damage and flash tube ionization.
- Combination permanent and 1" NPT pipe mount cast aluminum base.
- Branch guard models also available.
- Lenses available in five safety colors.
- Five year, **HDP®** Heavy-Duty Professional Warranty on power supply; two year warranty on Gold Medallion flash tube.



# WHELEN®

## S360D Series Specifications

Component optic design features inner optic ring and spreader lens molded inside dome. Top and bottom metalized conical reflectors redirect light energy into horizontal plane, intensifying light pattern. Top reflector doubles as built-in sun shade.

Larger dome provides 36 square inches of frontal illumination. Smooth outer surface resists dirt build-up.

Precision 1-1/2 turn, vertically wound Xenon flash tube and reflector assembly is highly vibration resistant. Plug-in assembly is easily field replaceable. (Model: "STUBE")

Nylon clamp ring provides weathertight seal.

Fully enclosed cast aluminum base.

Power supply is fully modular and easily field replaceable. Patented clamp circuit prevents power supply damage in the event of flash tube failure.

Easy to install with a two wire connection, S360D beacons are shipped pre-set with CometFlash® flash pattern and high-intensity operation. Internal connectors provide plug-in access to many added operational features using customer supply switches.

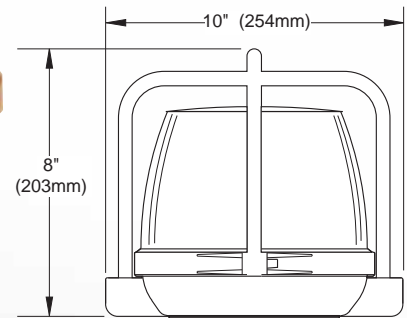
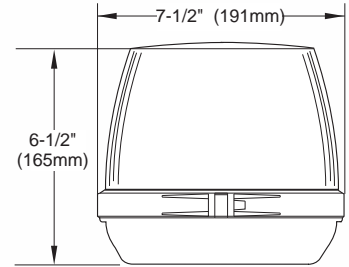

### MODELS

**S360D\*P** ..... Permanent/Pipe Mount

**S360D\*B** ..... Branch Guard Mount

\* Replace symbol in model number with letter indicating lens color desired:

A=Amber; B=Blue; C=Clear; R=Red; G=Green.

Due to variations in vehicle surfaces and operating conditions, the use of any magnetic mounted warning beacon on the vehicle while in motion is at the discretion and risk of the user.

### OPTIONS

**SSTUBE** ..... Super Strobe® Helix 1-1/2 turn strobe tube and polished reflector for DOT6H, S360C/S360D Series, SS361, SS363, SS364

### GENERAL ELECTRICAL AND PHYSICAL DATA

Input Voltage: ..... 12.8 VDC / 25.6 VDC

Input Current: ..... 3.4 amps / 1.7 amps

Input Power: ..... 43 Watts

Output Power: ..... 30 Watts

Output Energy: ..... 24 joules, 12.6/3.8/3.8/3.8 joules<sup>1</sup>

Effective Candle Power: ..... 760 Candella<sup>2</sup>

Flashrate: CometFlash® .... 75 FPM

DoubleFlash .... 115 FPM

Rapid Random

Flash™ ..... 225 FPM

ActionFlash™ .... 1 CF - 4 RRF<sup>3</sup>

Operating Temperature: ..... -30°F (-34°C) to +120°F (49°C)

Weight: ..... 3 lbs. 5 oz. (1.58 kg)

1. CometFlash Pattern.

2. Measured in Clear. For peak candlepower, multiply by 13,500.

3. ActionFlash is a combination pattern that repeats one CometFlash and four Rapid Random Flash Rate Flashes.



Whelen Engineering reserves the right to upgrade and improve products without notice.  
© 2010 Whelen Engineering Company, Inc. Printed in U.S.A.  
NASCAR® is a registered trademark of the National Association for Stock Car Auto Racing, Inc  
Code No. 10504E - 051310

**WHELEN®**  
ENGINEERING COMPANY, INC.

51 Winthrop Road  
Chester, Connecticut 06412-0684  
(860) 526-9504 • Fax: (860) 526-4078  
www.whelen.com

American Employees, American Manufacturing, American Pride!