



Global Traffic  
Technologies

Wiring and Programming Instructions

August 2009

## Opticom<sup>™</sup> Infrared System

Model 795H Low-profile LED Emitter

Model 795L Low-profile LED Emitter

## Table of Contents

|  |           |
|--|-----------|
| <b>1 About This Manual</b> .....   | <b>1</b>  |
| 1.1 Purpose of Manual .....  | 1         |
| 1.2 Manual Conventions .....   | 1         |
| 1.3 Manual Organization .....  | 1         |
| <b>2 Safety Information</b> .....  | <b>2</b>  |
| 2.1 Intended Use .....   | 2         |
| 2.2 Technical Support .....  | 2         |
| 2.3 Safety Messages and Safety Labels .....                                | 2         |
| 2.3.1 Safety Message Format .....  | 2         |
| 2.3.2 Safety Label Format.....   | 3         |
| 2.4 Safety Messages Contained in this Manual.....                          | 4         |
| 2.5 Safety Considerations .....  | 5         |
| 2.5.1 Personal Safety Equipment and Clothing.....                          | 5         |
| 2.5.2 Electric Shock.....  | 5         |
| 2.5.3 Explosion.....   | 5         |
| 2.5.6 Chemical Burns .....   | 5         |
| 2.6 Disposal of Device .....   | 5         |
| <b>3 Description</b> .....   | <b>6</b>  |
| 3.1 Opticom™ System.....   | 6         |
| 3.2 Model 794H and 794L Emitters .....                                     | 7         |
| <b>4 Features</b> .....  | <b>8</b>  |
| <b>5 Switch Installation and Wiring</b> .....                              | <b>9</b>  |
| 5.1 Emitter Control Switch Installation .....                              | 9         |
| 5.2 Individual Switch Installation.....                                    | 13        |
| 5.3 Final Wiring Connections .....   | 15        |
| 5.3.1 Power Connection Recommendations .....                               | 16        |
| 5.3.2 Power Connection Testing.....  | 16        |
| 5.4 Emitter Cable Connector Pin Index .....                                | 17        |
| 5.5 Emitter Programming .....  | 17        |
| <b>6 Checkout</b> .....  | <b>19</b> |
| 6.1 Installation Checkout.....   | 19        |
| 6.2 Performance Tests .....  | 20        |
| <b>7 Range Setting (Signal Intensity Threshold Level Adjustment)</b> ..... | <b>21</b> |
| <b>8 Maintenance</b> .....   | <b>22</b> |

## 1 About This Manual

### 1.1 Purpose of Manual

This manual provides step-by-step instructions for wiring and programming the Global Traffic Technologies Opticom™ Infrared System Model 795H and 795L Low-profile LED Emitters\*. It does not include information about installing it inside of light bars. Please refer to the manual provided by your light bar manufacturer for those details. It is intended for use by installers, maintenance personnel, and others who are responsible for the installation and maintenance of the system.

### 1.2 Manual Conventions

The conventions listed in Table 1-1 help to make this manual easier to use by presenting a uniform approach to the descriptions, phrases, and nomenclature.

### 1.3 Manual Organization

This manual is divided into eight sections.

#### Section 1. About This Manual

Contains information about the organization and content of this manual.

#### Section 2. Safety Information

Contains important information about the safety messages, safety labels, safety precautions, and procedures for installation of this device.

#### Section 3. Description

Briefly describes the Model 795 emitters and their related Opticom Infrared system components.

#### Section 4. Features

Describes important features and characteristics of the Model 795 emitters.

#### Section 5. Wiring and programming

Contains step-by-step wiring and programming instructions.

#### Section 6. Checkout

Contains information on how to check out and test the installed system.

#### Section 7. Signal Intensity Threshold Level Adjustment (Range Setting)

Contains information about adjusting the range.

#### Section 8. Maintenance

Contains information and recommendations to ensure reliable system operation.

**Table 1-1 Manual Conventions**

| Element         | Convention   | Example   |
|-----------------|--|---|
| Model names     | First or formal reference: initial caps<br>Subsequent use or informal reference: Initial caps for <i>Model</i> , lowercase for remainder | Opticom™ Infrared System Model 795H LED Emitter<br>Model 795H emitter, or the emitter |
| Feature names   | Initial caps   | the Disable feature   |
| Switch position | Uppercase  | the OFF position  |

\*The method of using the components of the Opticom™ Infrared System may be covered by US Patent Number 5172113.

## 2 Safety Information

We provide important safety information and warnings to assist you in understanding and avoiding potential harm to yourself, and possible damage to equipment, during the installation of Opticom™ Infrared System equipment. Although we have included many potential hazards you may encounter during the installation of this equipment, we cannot predict all of the possible hazards and this list should not be a substitute for your judgment and experience.

**Please read and observe all safety information and instructions in this manual before installing the system equipment. Also, save this installation manual and keep it near the equipment.**

If you are unsure about any part of this installation or of the potential hazards discussed, please contact your supervisor immediately.

### 2.1 Intended Use

The system is intended to assist authorized priority vehicles through signalized intersections by providing temporary right-of-way through vehicle operator interface to the system and through the use of common traffic controller functions.

### 2.2 Technical Support

If you have questions about the system, its use, or operation, please contact your dealer or call the GTT Technical Service department at 1-800-258-4610.

### 2.3 Safety Messages and Safety Labels

We include safety messages and safety labels in this manual to help you protect your safety and the safety of others. This section contains important information to help you recognize and understand these safety messages.

**Please read all messages before proceeding with the installation.**

#### 2.3.1 Safety Message Format

Safety messages are designed to alert you to potential hazards that can cause personal injury to you or others. They can also indicate the possibility of property damage.

Each safety message box contains a safety alert symbol (); one of three signal words: DANGER, WARNING, or CAUTION; and a safety message.

The signal words and symbols, and their meanings, are shown below:



**DANGER means that DEATH or SERIOUS INJURY or PROPERTY LOSS or DAMAGE is likely to occur if the instructions are not carefully followed.**



**WARNING means that SERIOUS INJURY or PROPERTY LOSS or DAMAGE may result if the instructions are not carefully followed.**

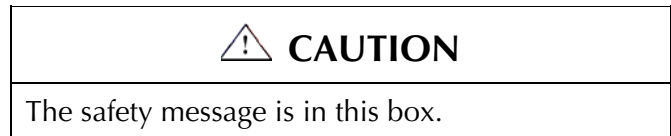

**CAUTION means you and/or someone else MAY be HURT or property damage may result if you do not follow these instructions.**

In addition to the symbols and words explained above, each safety message identifies the hazard, describes what you can and should do to avoid the risk of exposure to the hazard, and tells the probable consequences of not avoiding the hazard.

### 2.3.2 Safety Label Format

We include safety labels on the devices to help you protect your safety and the safety of others. Safety labels are designed to alert you to potential hazards associated with a piece of equipment that can cause personal injury to you or others. They can also indicate the possibility of property damage.

#### Please read all safety labels.

Each safety label contains a safety alert symbol (); one of three signal words: DANGER, WARNING, or CAUTION; a pictorial showing the nature of the hazard; and a safety message.

The signal words and symbols, and their meanings, are shown below:

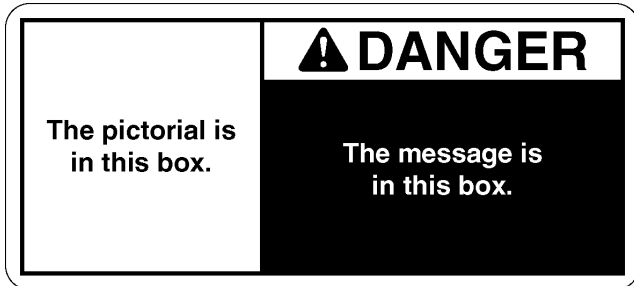

Opticom-242A

**DANGER** means that **DEATH** or **SERIOUS INJURY** or **PROPERTY LOSS** or **DAMAGE** is likely to occur if the instructions are not carefully followed.

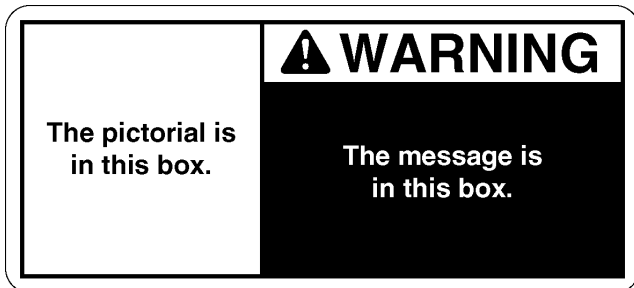

Opticom-243A

**WARNING** means that **SERIOUS INJURY** or **PROPERTY LOSS** or **DAMAGE** may result if the instructions are not carefully followed.

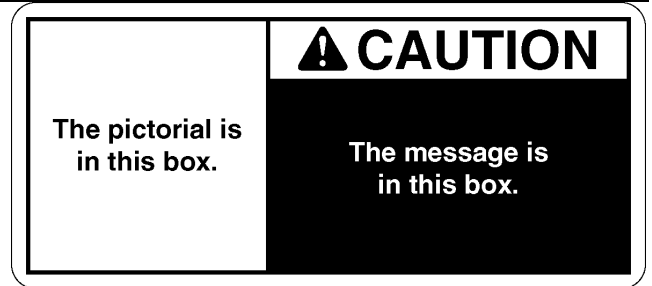

Opticom-244A

**CAUTION** means you and/or someone else **MAY** be **HURT** or **property damage** may result if you **do not follow these instructions**.

We consider safety labels to be an important part of all devices and they should be replaced immediately if they become hard to read.

If any of the safety labels are missing, or cannot be read, please contact your dealer or the GTT Technical Service department for a replacement.

## 2.4 Safety Messages Contained in this Manual

The following safety messages appear in this manual:

### DANGER

Vehicle batteries contain sulfuric acid and may contain explosive gases. **Keep sparks, flames, and cigarettes away. Wear eye protection. Disconnect the negative cable first to prevent shorting the positive terminal to the chassis when removing the positive cable.** Battery acid may cause skin irritation and eye injury. Explosive gases may cause severe injury or death.

### CAUTION

Connecting power to a power distribution system may not offer the current capacity or protection of direct connection to the battery, which may result in damage to the equipment or vehicle. **To avoid this problem, make the power connection directly to the battery or as close to the battery as possible.** An improper power connection may result in damage to the equipment or vehicle.

### WARNING

The system should ALWAYS be TESTED to verify the proper operation of the system. There are many variables in normal traffic operation and although it is not likely that the system can place an intersection into a dangerous configuration, the traffic signals should always be obeyed.

### WARNING

For proper system operation, the range and timing chart that corresponds to the model of detector that is being adjusted should always be used. The use of an incorrect range and timing chart may cause improper system operation and may adversely affect normal traffic operations; therefore, the traffic signals should always be obeyed.

### WARNING

A VISIBLE-LIGHT filtered strobe based emitter or an LED based emitter should be USED to set the ranges to avoid improper system operation. An improper system operation may occur if a clear lens strobe based emitter is used to set ranges. The effect of using a clear lens strobe based emitter to set ranges is a factor among many variables that may affect normal traffic operation and may adversely affect system performance.

---

## 2.5 Safety Considerations

Please consider the following safety issues before beginning the installation.

Although we have compiled this list of common safety considerations, it should not be considered as complete. It is not intended to take the place of your good judgment, training, and experience.

### 2.5.1 Personal Safety Equipment and Clothing

Personal safety equipment and clothing including high visibility vests, hard hats, gloves, electrical shock or electrocution protection clothing and equipment, safety shoes, safety glasses, face shields, goggles, and hearing protection devices are just some of the items available to you.

Choose the right equipment for the job. If you are unsure of which safety equipment is recommended or appropriate for the job, ask your supervisor or foreman.

### 2.5.2 Electric Shock

As a trained installer of electrical equipment you are aware of the dangers associated with installation of electrical devices. Always be sure that the power to the equipment, and all associated equipment, is turned off and the vehicle battery is disconnected. We also recommend that you wait for the period of time specified in the warning message before beginning any procedure. This waiting period is required to allow electrically charged components to discharge and minimize your exposure to the risk of electric shock and electrocution. Use the equipment, techniques, and procedures that you learned during your training or apprenticeship or other electrical industry recognized safety procedures.

If you are unsure of which techniques, procedures, and protective equipment are recommended or appropriate for the job, ask your supervisor or foreman.

### 2.5.3 Explosion

Common automotive-type batteries produce an explosive gas under some conditions. This gas may easily be ignited by a spark or flame as you work on the vehicle. To reduce the risk of explosion, disconnect the battery, work in a well ventilated area, avoid the use of devices that create sparks or use open flames, and use the appropriate personal safety equipment and clothing.

If you are unsure of which techniques, procedures, and protective equipment are recommended or appropriate for the job, ask your supervisor or foreman.

### 2.5.4 Chemical Burns

Common automotive-type batteries contain strong acid that can cause personal injury if you come in contact with the acid. To reduce exposure to the risk of chemical burns wear appropriate protective clothing and handle the battery with care.

If you are unsure of which techniques, procedures, and protective equipment are recommended or appropriate for the job, ask your supervisor or foreman.

## 2.6 Disposal of Device

Please dispose of the device in accordance with all local, state, and federal laws and regulations.

### 3 Description

This section provides a general description of the Opticom™ Infrared System and a detailed description of Model 795H and 795L LED Emitters.

#### 3.1 Opticom™ System

The system assists authorized priority vehicles through signalized intersections by providing temporary right-of-way through the use of common traffic controller functions. The Probe mode records and communicates information (for example, vehicle location, travel direction, user class and identification) which can be used to provide traffic flow information by calculating the rate of movement of designated probe vehicles.

The Opticom system consists of the following matched components:

- **Emitter** — Model 795 Emitter.
- **Detector** — Model 711, 721, and 722 Detectors and Model 138 Detector Cable. Also auxiliary interface panels, if auxiliary detectors are used.
- **Phase Selector** — Such as Model 752 and 754 Phase Selectors.
- **Card Rack/Input File** — Model 760 Card Rack or California/New York Type 170 Controller Input File.

The emitter, with an appropriate emitter control switch, is mounted on the priority vehicle. It generates a series of pulses in the infrared wavelength. These pulses are sensed by the detector mounted at the intersection.

The detector converts the infrared energy into electrical signals that are transmitted by the detector cable to the phase selector in the traffic controller cabinet.

For Priority Control mode, the phase selector discriminates between valid emitter signals and other sources of energy received by the detectors, and activates its outputs in response to valid priority emitter signals. The phase selector outputs are connected to the traffic controller's inputs, to request the traffic controller to deliver the desired green for the priority vehicle.

For Probe mode, the phase selector logs the user class, identification, and time, but does not send any signals to the traffic controller.

Interface cards are required in applications where the controller cannot recognize external priority control signals. Interface cards are electrically connected between the phase selector and the traffic controller.

The card rack/input file provides the power and logic wiring for the phase selector, which plugs directly into a slot in the unit.

## 3.2 Model 795H and 795L Emitters

Opticom™ Infrared System Model 795H, L LED Emitters are compact, weather-resistant, infrared energy-emitting devices with optional encoded-signal operation. These emitters are intended for use on priority vehicles. The emitter system consists of an LED module with a built-in power supply, an emitter cable, and the appropriate emitter control switch.

The Model 795H and 795L emitters emit light in the infrared portion of the spectrum only.

### Notes:

- **Only the visible LEDs will be seen as flashing. The Infrared LEDs will be flashing but they are not visible. They may be viewed through a digital camera or a cell phone camera.**
- **Clear lens strobe based emitters produce slightly different signal strengths. If your system includes vehicles with clear lens strobe based emitters and vehicles with strobe based visible-light filtered emitters, you may perceive a slight reduction in range when operating the system with a visible-light filtered emitter or when used with older generation Opticom detectors. Operators of vehicles equipped with visible-light filtered strobe emitters and LED emitters may report inadequate range or slow signal light response time when used on these older detectors.**
- **If your system includes vehicles with clear lens strobe based emitters, vehicles with visible-light filtered strobe based emitters and LED based emitters with the same priority level, we recommend that you set the ranges for every intersection in your system using a visible-light filtered emitter or LED based emitter. Setting (or resetting) ranges with a visible-light filtered strobe based emitter or LED based emitter will ensure proper system performance for both visible-light filtered strobe based emitters, clear lens strobe based emitters and LED based emitters.**

The Model 795H is programmed to provide High-Priority operation. The Model 795L emitter is programmed to provide Low-Priority operation.

Appropriate vehicle Class and ID numbers are determined at the time of installation and are programmed by the user via Model 790-CS configuration software.

Two emitter switch configurations are available as accessories for Model 795H and 795L emitters. All three switch configurations include emitter diagnostic indicators.

- The Model 793S emitter control switch is a custom-designed, fully-enclosed switch assembly consisting of an alternate-action, push-button switch with a positive latch down in the ON position, and an indicator light. A mounting bracket is included. This emitter control switch is intended to be used as an emitter on/off switch for any Priority. The switch is mounted in the vehicle operator's compartment.
- The Model 793B emitter control switch is a double-pole, single-throw rocker switch with an indicator light. A simple mounting bracket is included. This emitter control switch is intended to be used as an emitter on/off switch in custom switch panels in the vehicle operator's compartment.

---

## 4 Features

Opticom™ Infrared System Model 795H, 795L  
Emitters have the following features:

- Mounts in most lightbars
- LED Infrared light source
- Very low current consumption, less than 200mA
- Integrated power supply and LED array for small size
- Impact resistant design
- Fixed flash rate:  
High Priority = 14 Hz  
Low Priority = 10 Hz
- Vehicle identification encoding; selectable at installation
- User-selectable disable mode; Latching or Non-Latching modes
- Disable circuitry (indicator flashes at 0.5 Hz)
- Self-diagnostic capability (indicator flashes at 2 Hz)

User configurable visible LEDs

- 10,000 vehicle identification codes for each priority/frequency
- Wide operational temperature range:  
–30°F to +140°F
- Meets FCC part 15 subpart J Class A specifications
- CE certified
- SAE J575 JUN92 compliant
- J1708 compliant communication port
- Available Windows™<sup>1</sup> Configuration and Maintenance Software

---

<sup>1</sup> Windows is a trademark of Microsoft Corporation.

## 5 Switch Installation and Wiring

### 5.1 Emitter Control Switch Installation

This subsection describes the installation of the Optional Model 793S emitter control switch. It also describes how to connect the emitter cable from Model 795H and 795L emitters to the emitter control switch.

#### Notes:

**Please read and fully understand the following precautionary notes before installing the emitter control switch.**

- Emitter installations may include a customer-supplied disable switch in addition to the emitter control switch. The Disable feature turns off the emitter when the disable switch closes to battery negative. This feature typically uses an existing switch that indicates the presence of conditions deemed appropriate to disable the emitter. Such conditions include putting the transmission in park, setting the parking brake, or opening the vehicle operator's door. The use of a disable switch is highly recommended so that emergency vehicle drivers do not need to remember to shut off their emitter when arriving at the scene. Without using this feature, nearby intersections may be unnecessarily held in preemption by vehicles at the scene.
- The emitter control switch location must be readily accessible to the vehicle operator.
- The emitter control switch must not be in the path of airbag deployment.
- The emitter cable is routed between the emitter, the emitter control switch, the disable switch, and the battery.
- Use care when drilling holes to avoid drilling into undesirable locations.

1. Determine the desired location to mount the emitter control switch. Mark and drill two 7/32-inch holes, using the emitter control switch mounting bracket as a template.
2. Insert the two 10-32 x 3/4-inch cap screws through the holes in the mounting bracket and mounting surface. See Figure 5-4.
3. Use the two lock washers and 10-32 nuts to secure the bracket to the vehicle.

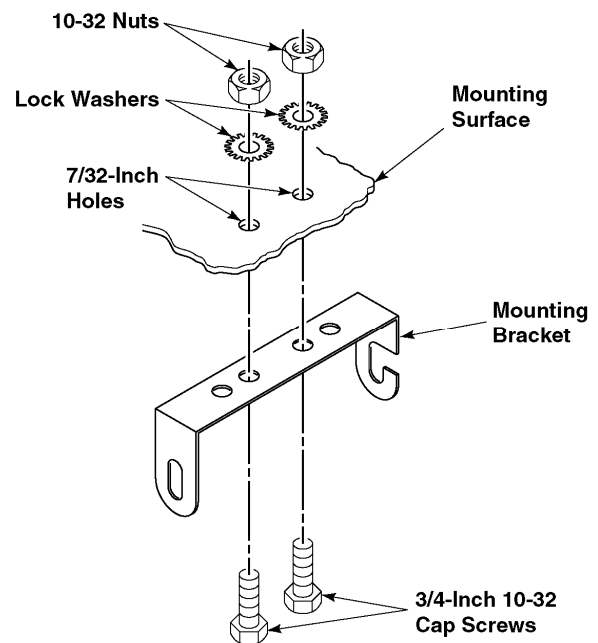

**Figure 5-4. Emitter Control Switch Mounting Bracket Installation**

- 
- Cut the Opticom™ Infrared System Model 795H and 795L LED Emitter cable to the proper length. Remove about 6 inches of the outer jacket from the end of the cable. Be careful not to cut the wires inside.

Strip 1/4-inch of insulation from the black, red, green, and orange wires. Cut off the blue and gray wires.

- Insert the black wire into one end of an insulated butt splice connector and crimp. Connect the other end of the connector to a customer-supplied black wire (16 AWG, long enough to connect to the battery negative terminal). See Figure 5-5.
- Install a spade lug on the red wire and connect it to the terminal labeled RED on the back of the emitter control switch.
- Install a spade lug on the green wire and connect it to the terminal labeled GREEN on the back of the emitter control switch.

**NOTE:**

**The orange wire enables the range-setting option. For ease of installation, the orange wire is always connected. Only Model 793R emitter control switches, with the range-setting switch, will be able to use this option.**

- Install a spade lug on the orange wire and connect it to the terminal labeled ORANGE on the back of the emitter control switch.
- Strip 1/4-inch of insulation from a customer-supplied red wire (16 AWG) and install a spade lug on it. Connect the red wire to the terminal labeled BATTERY on the back of the emitter control switch.
- Connect the free end of the red wire to the fuse holder. Connect the other end of the fuse holder to a customer-supplied red wire (16 AWG, long enough to connect to the battery positive terminal). Do not install the fuse yet.
- Install the fuse rating label on the red wire near the fuse holder.

- Place the Model 793S emitter control switch into the mounting bracket. Use the two 1/4-inch acorn nuts and lock washers to secure the switch box to the bracket. See Figure 5-6.

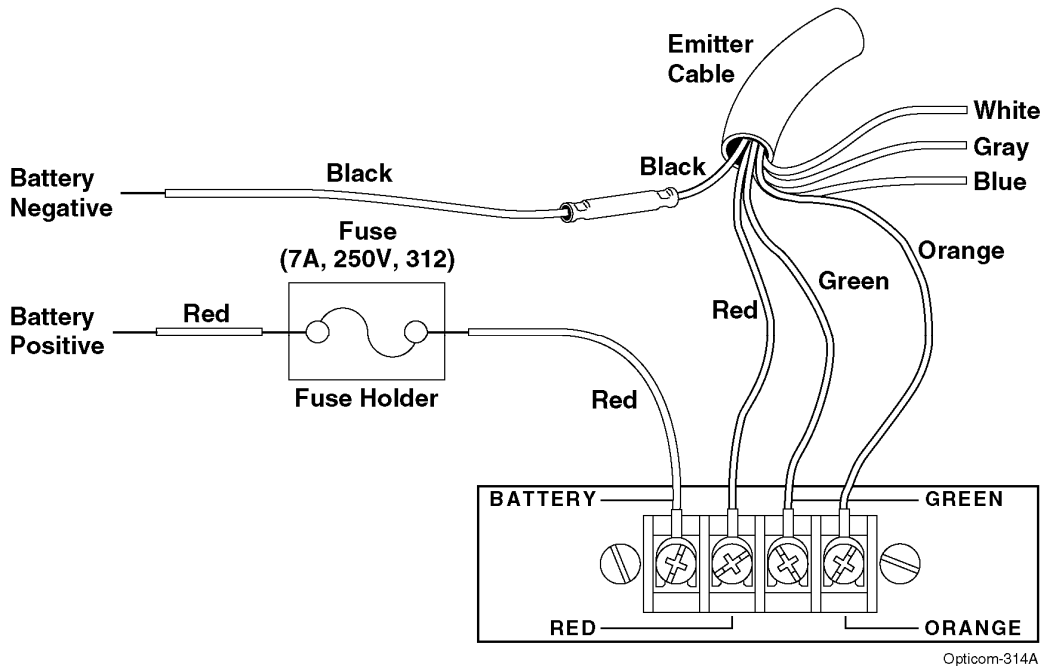

Opticom-314A

Figure 5-5. Model 793S Emitter Control Switch Wiring

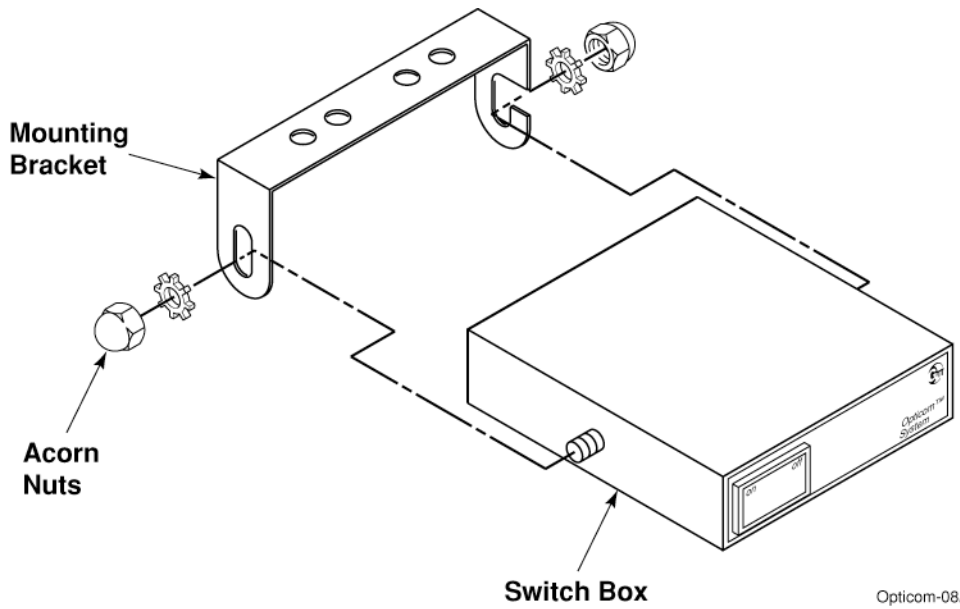

Opticom-08A

Figure 5-6. Emitter Control Switch Installation

13. To install the Disable feature with an Opticom™ Infrared System Model 793S Emitter Control Switch, continue with step 14.

If the Disable feature is not being installed, cut off the white wire and go to Subsection 5.4, Final Wiring Connections.

**NOTE:**

- **The use of a disable switch is highly recommended so that emergency vehicle drivers do not need to remember to shut off their emitter when arriving at the scene. Without using this feature, nearby intersections may be unnecessarily held in preemption by vehicles at the scene.**
14. Strip 1/4-inch of insulation from the white wire and insert it into one end of an insulated butt splice connector and crimp.
15. Strip 1/4-inch of insulation from a customer-supplied white wire (16 AWG) and insert it into the unused end of the connector and crimp.

16. Connect the free end of the white wire to a disable switch terminal.

**NOTES:**

- **The disable switch must connect to battery negative when the switch is activated.**
  - **Test the switch. If the switch is connected to another wire and that wire is not connected to battery negative use a separate disable switch. GTT recommends a switch made by ECHLIN®<sup>2</sup> (Part # DJ 6402). This switch is available at NAPA®<sup>3</sup> Auto Parts.**
17. Make sure the other terminal of the disable switch is connected to battery negative. If you are using a separate switch, connect it to a customer-supplied white wire (16 AWG, long enough to connect to the battery negative terminal).
18. Go to Subsection 5.4, Final Wiring Connections.

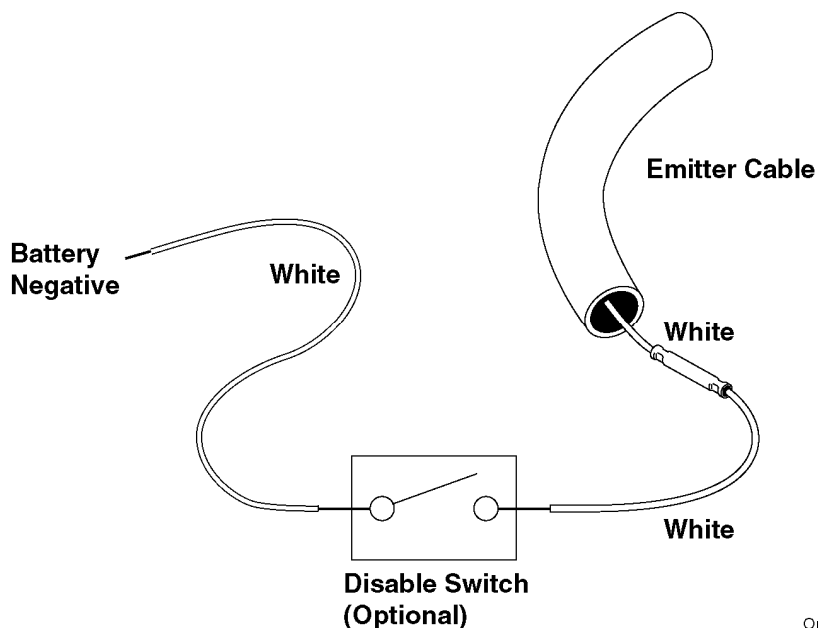

Opticom-286A

**Figure 5-7. Disable Switch Wiring**

<sup>2</sup> ECHLIN is a registered trademark of ECHLIN, Incorporated.

<sup>3</sup> NAPA is a registered trademark of National Automotive Parts Association.

## 5.2 Individual Switch Installation

This subsection describes the installation of the optional Model 793B emitter control switch or a customer-supplied on/off switch with an indicator lamp. It also describes how to connect the emitter cable from Model 795H and 795L emitters to the on/off switch.

**Please read and fully understand the following precautionary paragraphs before installing the emitter control switch.**

### NOTES:

- Emitter installations may include a customer-supplied disable switch in addition to the on/off switch. The Disable feature turns off the emitter when the disable switch closes to battery negative. This feature typically uses an existing switch that indicates the presence of conditions deemed appropriate to disable the emitter. Such conditions include putting the transmission in park, setting the parking brake, or opening the vehicle operator's door. The use of a disable switch is highly recommended so that emergency vehicle drivers do not need to remember to shut off their emitter when arriving at the scene. Without using this feature, nearby intersections may be unnecessarily held in preemption by vehicles at the scene.
  - Customer-supplied on/off switches must be rated at 24 VDC, 1 Ampere, 100,000 actuations, and must contain an internal indicator lamp (rated at +14 VDC). See Figure 5-8.
  - The on/off switch location must be readily accessible to the vehicle operator.
  - The on/off switch must not be in the path of airbag deployment.
  - The emitter cable is routed between the emitter, the on/off switch, the disable switch, and the battery.
  - Use care when drilling holes to avoid drilling into undesirable locations.
1. Install the on/off switch at the desired location. Use the mounting bracket as a template when drilling holes.
  2. Cut the emitter cable to the proper length. Remove about 6 inches of the outer jacket from the end of the cable. Be careful not to cut the wires inside.
  3. Strip 1/4-inch of insulation from the black, red, and green wires. Cut off the blue, gray, and orange wires.

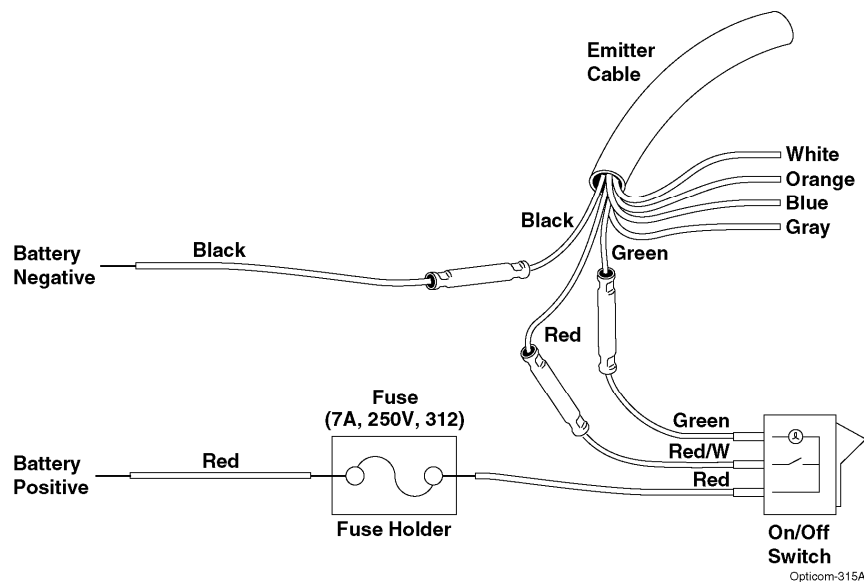

Figure 5-8. Model 793B On/Off Switch Wiring

Note: On some 793B switches, the wire listed as Red/W (red with a white stripe) will be White/Red (white with a red stripe.)

4. Insert the black wire into one end of an insulated butt splice connector and crimp. Connect the other end of the connector to a customer-supplied black wire (16 AWG, long enough to connect to the battery negative terminal). See Figure 5-8.
5. Insert the red wire from the Opticom™ Infrared System Model 795H and 795L LED Emitter cable into one end of an insulated butt splice connector and crimp. Connect the other end of the connector to the red/white wire from the on/off switch.
6. Connect the red wire from the on/off switch to the fuse holder. Connect the other end of the fuse holder to a customer-supplied red wire (16 AWG, long enough to connect to the battery positive terminal). **Do not install the fuse yet.**
7. Install the fuse rating label on the red wire near the fuse holder.
8. To install the Disable feature, continue with step 9. If the feature is not being installed, cut off the white wire and go to Subsection 5.4, Final Wiring Connections.
9. Strip 1/4-inch of insulation from the white wire and insert it into one end of an insulated butt splice connector and crimp.
10. Strip 1/4-inch of insulation from a customer-supplied white wire (16 AWG) and insert it into the unused end of the connector and crimp. Connect the free end of the white wire to a disable switch terminal. See Figure 5-9.

**NOTES:**

- **The disable switch must connect to battery negative when the switch is activated.**
- **Test the switch. If the switch is connected to another wire and that wire is not connected to battery negative use a separate disable switch. GTT recommends a switch made by ECHLIN® (Part # DJ 6402). This switch is available at NAPA® Auto Parts.**

11. Make sure the other terminal of the disable switch is connected to battery negative. If you are using a separate switch, connect it to a customer-supplied white wire (16 AWG, long enough to connect to the battery negative terminal).
12. Go to Subsection 5.4, Final Wiring Connections.

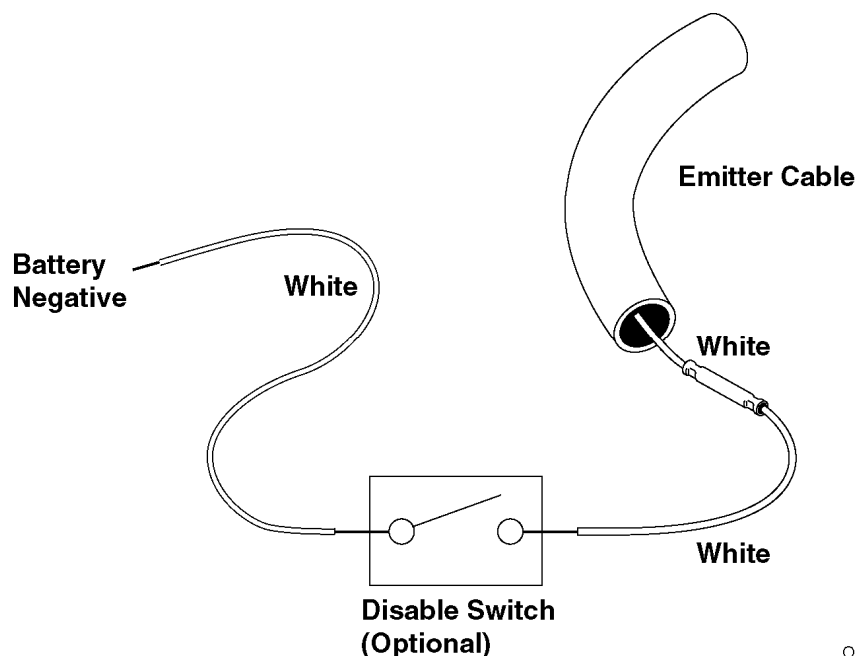

Opticom-286A

**Figure 5-9. Disable Switch Wiring**

### 5.3 Final Wiring Connections

1. Cut off, tape off, or insulate and secure all unused wires at the end of the Model 795H and 795L emitter cable.
2. Route the customer-supplied red, black, and white wires to the battery. (Use the white wire only when installing the Disable feature.) See Figure 5-10.
3. Connect the black wire from the emitter cable to the battery negative (-) terminal.
4. If the optional disable switch is installed, connect the white wire from the disable switch to the battery negative (-) terminal.
5. Connect the red wire from the fuse holder to the battery positive (+) terminal.
6. Verify that the emitter control switch on/off switch is set to the OFF position.
7. Inspect all connections and verify that the wiring is complete and accurate as shown in the wiring diagrams in this installation manual.
8. Install an installer provided fuse (1 amp) in an installer provided fuse holder.
9. Connect the vehicle's positive battery cable, and then connect the negative battery cable.

|  <b>CAUTION</b>  |
|---|
| <p>Connecting power to a power distribution system may not offer the current capacity or protection of direct connection to the battery, which may result in damage to the equipment or vehicle. <b>To avoid this problem, make the power connection directly to the battery or as close to the battery as possible.</b> An improper power connection may result in damage to the equipment or vehicle.</p> |

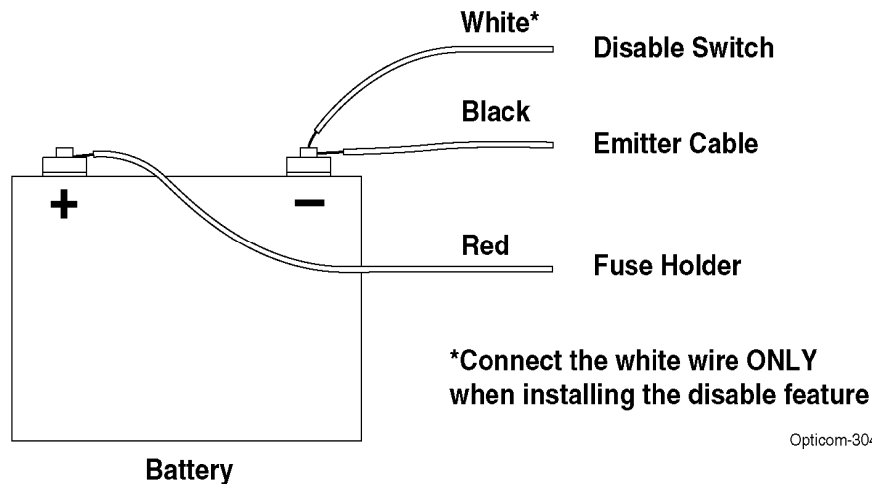

**Figure 5-10. Battery Connections**

---

### 5.3.1 Power Connection Recommendations

When installing Opticom™ Infrared System Model 795H and 795L LED Emitters, GTT recommends connecting the emitter directly to the vehicle battery as specified in Subsection 5.4, Final Wiring Connections.

If you are not going to connect the emitter directly to the battery, please consider the following:

#### NOTES:

- **Always utilize a 12 VDC power distribution point as close to the battery as possible.**
- **The emitter must be connected to a point that will continuously supply a minimum of 10 VDC under all operating conditions.**
- **Ensure the power source provides adequate current carrying capacity (1 amp minimum).**
- **Use insulated spade lug or butt-splice connectors to connect the emitter to the vehicle wiring.**
- **Always use a 1 amp fuse.**
- **Connect the emitter's ground connection (black wire) directly to the vehicle chassis ground.**
- **Use conductive grease on the ground connection.**
- **Do not use insulation displacement connectors.**
- **Never connect the emitter power or ground circuit common to any life support or monitoring system.**
- **If you choose to use the lightbar switch to activate the emitter, connect the emitter's power connection to the lightbar relay output; not the relay coil switch.**

### 5.3.2 Power Connection Testing

Measure the resistance between battery ground and emitter ground using the following procedure:

1. Connect an ohmmeter (set to its lowest scale) between the battery negative (–) terminal and the emitter ground connection.
2. Measure the resistance. The resistance should be less than 1 ohm.
3. If the resistance is greater than 1 ohm, find a grounding point for the emitter that meets the requirements in step 2.

Measure the voltage to the emitter using the following procedure:

1. With the vehicle running and operating in full response mode, check the voltage using a voltmeter connected to the red (+) and black (–) wires of the emitter cable.
2. Under no circumstances should the voltage be less than 10 VDC. If it is less, find a power connection point that provides a minimum of 10 VDC for the emitter.

## 5.4 Emitter Cable Connector Pin Index

Table 5-1 lists the pin index for the Model 794H and 794L emitter cable connector. Figure 5-11 shows the pin view of the emitter cable connector and Figure 5-12 shows the socket view.

**Table 5-1. Emitter Cable Connector Pin Index**

| Pin | Wire Color | Function                      |
|-----|------------|-------------------------------|
| 1   | Gray       | J1708 (-)                     |
| 2   | White      | Disable (input)               |
| 3   | Orange     | Range setting enable (input)  |
| 4   | Red        | +12 VDC                       |
| 5   | Not Used   | Not Used                      |
| 6   | Blue       | J1708 (+)                     |
| 7   | Black      | DC return                     |
| 8   | Green      | DC return for indicator light |

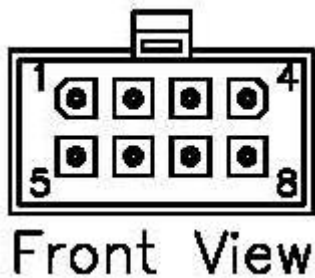

Figure 5-11. Emitter Pigtail Connector Pin View

**Do not cut off this connector. Cutting off this connector will void the warranty and prevent you from programming the emitter.**

## 5.5

### Emitter programming

Program the Vehicle ID code into the Model 795H and 795L emitter using the ITS Link/790-CS configuration software.

ITS Link Suite /790-CS is available for download at: <http://www.gtt.com/Tech-Support-Tools/Software-Downloads>.

Version 3.1 or later is required to support the Model 795.

1. Connect the 795 programming cable to the emitter cable. See Figure 5-14. The part number for the 795 programming cable is 79-1000-0157-0. A serial extension cable may also be needed. The GTT part number for this cable is 26-1014-5721-1.
2. Connect the interface cable RS-232 end to the programming computer.
3. Set the emitter control switch on/off switch to the ON position. The emitter should turn on.
4. Turn on the computer and start the ITS Link software program.
5. Select Opticom 790-CS.
6. Press the **Read from Device** button.
7. To set the disable mode, click the mouse button on either **Latching** or **Non-Latching**.

#### NOTES:

- **Latching mode turns the emitter off when the disable switch is activated. The emitter will not turn on until the disable switch is deactivated and the emitter control switch is turned off for 5 seconds and then turned back on.**
- **Non-Latching mode turns the emitter off when the disable switch is activated and turns it back on when the disable switch is deactivated.**
- **See the 790-CS online help file for more details.**

- To set the Vehicle ID code, click on **Class** in the Vehicle ID box. Then enter the desired vehicle class (**0 – 9**).

Click on **ID** in the Vehicle ID box. Then enter the desired vehicle ID (**000 – 999**). Numbers out of range will not be accepted.

**NOTE**

Factory defaults are **Class 0** and **ID 001**.

- Set the desired behavior of the visible LEDs.
- Click the **Apply** button.
- Exit from the configuration program.
- Set the emitter control switch on/off switch to the OFF position.
- Disconnect the interface cable assembly from the emitter cable and reconnect the emitter to the emitter cable (fully engage the locking ring).
- Set the emitter control switch on/off switch to the ON position. The emitter will turn on and flash the new ID sequence.

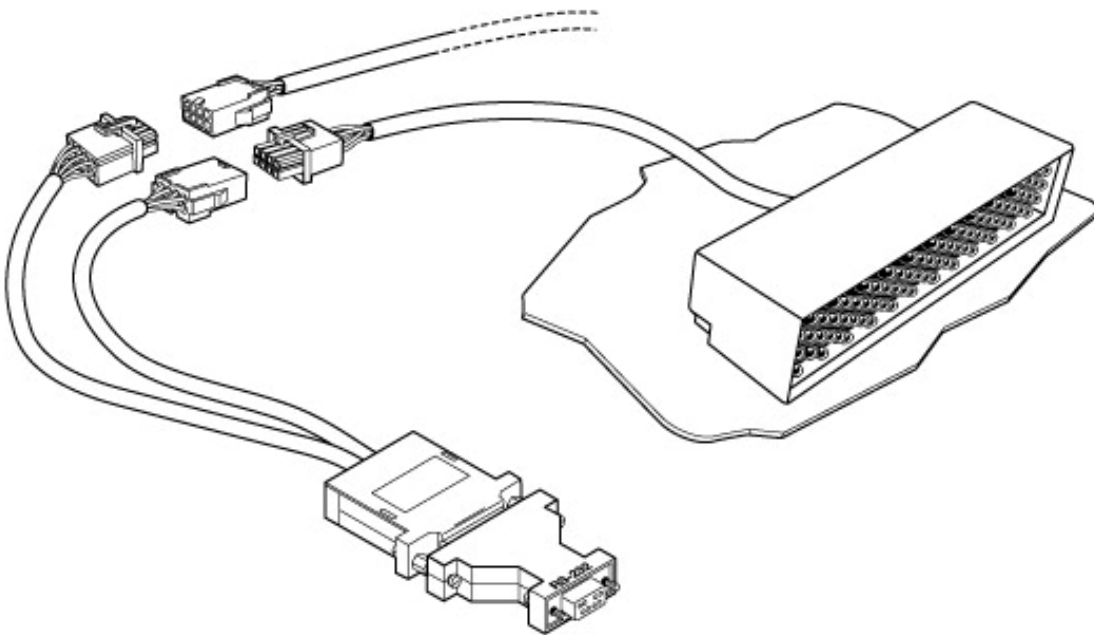

**Figure 5-13. Interface Cable Assembly**

## 6 Checkout

This section describes how to check out and test the installed system.

### 6.1 Installation Checkout

1. Set the on/off switch to the ON position. The Opticom™ Infrared System Model 795H and 795L LED Emitter visible LEDs should flash and the indicator in the on/off switch should light.

#### NOTES:

**The on/off switch indicator should not flash. If it does flash (about two times per second), verify that the wiring is correct. If the indicator continues to flash, substitute a known good unit. Return the defective unit for repair.**

**Only the visible LED will be seen as flashing. The Infrared LEDs will be flashing but they are not visible. They may be viewed through a digital camera or a cell phone camera.**

2. If the disable switch is installed and the Latching Disable mode is selected, test the disable circuit by activating the switch while the emitter is on. The emitter should stop flashing and the indicator in the on/off switch should flash once about every 2 seconds (0.5 Hz).

Deactivate the disable switch and turn the emitter off, wait 5 seconds, then turn the emitter on.

#### Note:

**With the Latching Disable mode selected, toggling the disable switch will not restart the emitter. The emitter will restart only after the on/off switch is set to OFF for a few seconds, then set back to ON.**

If the disable switch is installed and the Non-Latching Disable feature is selected, test the disable circuit by activating the switch while the emitter is on. The emitter should stop flashing and the indicator in the on/off switch should flash once about every 2 seconds (0.5 Hz).

Deactivate the disable switch. The emitter should turn back on.

3. If the emitter does not turn off and back on as described in steps 2 and 3, check the wiring against the wiring diagram for the disable switch. For Model 793S or 793B emitter control switches, see Figure 5-10.
4. Measure the voltage to the emitter with the vehicle operating in full response mode. Check the voltage using a voltmeter connected to the red (+) and black (–) wires of the emitter cable. The voltage should not be less than 10 VDC. If it is less, find a power connection point that provides a minimum of 10 VDC for the emitter. Refer to Subsection 5.3.1, Power Connection Recommendations.

---

## 6.2 Performance Tests

 **WARNING**

The system should ALWAYS be TESTED to verify the proper operation of the system. There are many variables in normal traffic operation and although it is not likely that the system can place an intersection into a dangerous configuration, the traffic signals should always be obeyed.

These installation instructions are the result of tests performed in our laboratory and we believe these tests to be accurate and complete. However, each installation involves variables that cannot be controlled or predicted. These variables may affect the operational characteristics of the system.

To ensure proper system operation, GTT strongly recommends that, when the system is turned on, the installer functionally tests the system using an Opticom™ Infrared system emitter-equipped vehicle. To test the system, the installer drives the priority vehicle through the intersection to verify that the system is performing in accordance with customer requirements.

## 7 Range Setting (Signal Intensity Threshold Level Adjustment)

To adjust the range (for any given intersection approach) using Opticom™ Infrared System Models 795H and 795L LED Emitters, refer to the *Model 752/754 Phase Selector Installation Instructions* manual. Follow the instructions that describe how to adjust the signal levels when using an emitter that does not have automated range setting capability.

The Model 795H and 795L LED based emitter has the following characteristics.

- Clear lens strobe based emitters, visible-light filtered strobe based emitters and LED based emitters, produce slightly different signal strengths. If your system includes vehicles with a mix of these emitters, you may perceive a slight reduction in range when operating the system on older generation detectors. Operators of vehicles equipped with visible-light filtered emitters may report inadequate range or slow signal light response time.

### **WARNING**

A VISIBLE-LIGHT filtered strobe based emitter or an LED based emitter should be USED to set the ranges to avoid improper system operation. An improper system operation may occur if a clear lens strobe based emitter is used to set ranges. The effect of using a clear lens strobe based emitter to set ranges is a factor among many variables that may affect normal traffic operation and may adversely affect system performance.

- If your system includes vehicles with both clear lens strobe based emitters, vehicles with visible-light filtered strobe based emitters and LED based emitters, we recommend that you set the ranges for every intersection in your system using a visible-light filtered strobe based emitter or an LED based emitter. Setting (or resetting) ranges with a visible-light filtered strobe based emitter will ensure proper system performance for visible-light filtered strobe based emitters, LED based emitters and clear lens strobe based emitters.

To adjust the range using the automated range feature, you must use a Model 792R or 794R emitter and Model 793R emitter control switch.

### **WARNING**

For proper system operation, the range and timing chart that corresponds to the model of detector that is being adjusted should always be used. The use of an incorrect range and timing chart may cause improper system operation and may adversely affect normal traffic operation; therefore, the traffic signals should always be obeyed.

## 8 Maintenance

Opticom™ system components are designed for reliable operation. Inspect the components at regular intervals to ensure proper system operation.

GTT recommends the following:

- Each intersection and emitter system should be inspected and tested at least every 12 months to ensure it functions to your specifications and requirements.
- Intersection systems should be tested with known good emitter systems.
- Emitter systems should be tested with known good intersection systems.
- You should develop a test plan that fits your department's operations and meets the needs of your system.
- You should keep accurate and up-to-date records of system performance and test results.

**Important Notice to Purchaser:**

EXCEPT FOR THE LIMITED WARRANTIES SET FORTH IN THIS DOCUMENT, GLOBAL TRAFFIC TECHNOLOGIES (GTT) MAKES NO OTHER WARRANTIES AND EXPRESSLY DISCLAIMS ALL OTHER WARRANTIES, WHETHER EXPRESS OR IMPLIED, INCLUDING, WITHOUT LIMITATION, ANY WARRANTY AS TO MERCHANTABILITY OR FITNESS FOR A PARTICULAR USE.

Global Traffic Technologies (GTT) will, at its sole option, replace or refund any amounts paid for any Opticom™ Infrared System Model 795H or 795L Low-Profile LED Emitter found to be defective in materials or manufacture within two (2) years from the date of shipment from GTT.

The warranties set forth in this document shall not apply to any Opticom infrared low-profile emitter which has been (1) repaired or modified by persons not authorized by GTT; (2) subjected to incorrect installation, misuse, neglect or accident; (3) damaged by extreme atmospheric or weather-related conditions; or (4) subject to events or use outside the normal or anticipated course.

IN NO EVENT SHALL GTT BE LIABLE FOR ANY INJURY (INCLUDING, WITHOUT LIMITATION, PERSONAL INJURY), DEATH, LOSS, OR DAMAGE (INCLUDING, WITHOUT LIMITATION, PROPERTY DAMAGE), WHETHER DIRECT, INDIRECT, INCIDENTAL, SPECIAL, CONSEQUENTIAL, OR OTHERWISE, ARISING OUT OF THE USE OR INABILITY TO USE, REPAIR OR FAILURE TO REPAIR, ANY GTT PRODUCT. REGARDLESS OF THE LEGAL THEORY ASSERTED. THE REMEDIES SET FORTH IN THIS DOCUMENT ARE EXCLUSIVE.

Sale and use of the Opticom infrared system is expressly restricted to authorized agencies of government customers, within their specific jurisdictions. However, because the infrared signal generated by the Opticom infrared system is not exclusive, GTT does not warrant exclusive activation by purchaser. Authorized users who desire to use or coordinate use of the Opticom infrared system with that of other jurisdictions must first obtain the prior written approval of each authorized user in the jurisdiction where use is sought.

Global Traffic Technologies, LLC  
7800 Third Street North  
St. Paul, Minnesota 55128-5441  
1-800-258-4610  
651-789-7333  
[www.gtt.com](http://www.gtt.com)

Global Traffic Technologies Canada, Inc.  
157 Adelaide Street West  
Suite 448  
Toronto, ON M5H 4E7  
Canada  
1-800-258-4610

Opticom is a trademark of Global Traffic Technologies, LLC  
Used under license in Canada  
Please recycle. Printed in the U.S.A.  
© Global Traffic Technologies, LLC 2007  
All rights reserved.  
79-1000-0316-0 Rev. A