

NOW available with
4 extra high intensity LED
corner modules **PLUS** true split
color combination
Traffic Advisor

WHELEN[®]

LFL LIBERTY[™]
Linear-LED[®] LIGHTBARS



Form# LIB0909

#1
WHELEN[®]
In Strobe & LED Technology

WHELEN® LFL LIBERTY™ SERIES

All the latest technology, all the super performance, high reliability features needed to give you maximum, heads up warning in an extreme low profile lightbar that's almost undetectable on the highways. Liberty lightbars are made for the rough treatment and long hours that your job demands. From the extruded aluminum chassis on up, every component is designed and field-tested for performance under just those conditions.

LIBERTY FEATURES

- An all Linear-LED lightbar featuring ultra bright, ultra wide-angle Super-LED technology providing heavy-duty long life operation (LED modules are rated 100,000 hours) with low current draw.
- Choose from the **NEW** extra high intensity corner module or the standard corner Linear Super-LED® modules.
- Full 360 degree coverage, SAE J845 Class 1 Certified in red, blue and amber colors.
- Choose the Linear Super-LED corner you want, then add up to 12 Linear Super-LED directional modules in pairs, for a total of 16 modules, at any time in the future at the distributor or end user level.
- Extended corner modules expand visibility to critical 90° angles.
- Build your lightbar in any color combination with take-downs and LED modules in any position you want.
- Sleek, aerodynamic design with state-of-the-art optics built on an extruded aluminum chassis providing shock protection, strength and stability without warping or sagging.
- Each Super-LED lighthouse is driven by an all electronic module that provides proper input power and choice of flash patterns.
- Optional brake/tail/turn lights and Traffic Advisors™ are available for additional warning.
- **NEW** LR11 Super-LED alley, take-down and work lights with 15° horizontal adjustment.
- Optional five/six lamp Super-LED Traffic Advisor with ultra high intensity Linear-LED modules or **NEW** Duo™ technology modules for combination Traffic Advisor and warning capability in a single lighthouse (WeCan Series only).
- Clear outer lenses are standard, optional color lenses are available.
- 5 year HDP® (Heavy-Duty Professional) warranty on LEDs and all models exceed SAE requirements.
- Wider footprint provides greater stability on the thinner roof construction of today's vehicles.
- Available adjustable mount foot allows the lightbar to be mounted parallel to the street surface, no matter the shape of the vehicle roof.
- Available Cruise Light function, low intensity steady-burn lighting, for identification and visibility of police vehicles during routine patrol.
- Optional Solar panel compensates for parasitic draw.
- **NEW** Photocell option for Hi/Low power.
- Size: 2-1/2" (64mm) H x 12" (304mm) W x 43-1/8" (109cm), 48-1/2" (123cm), 53-7/8" (137cm) L.



SX, SP or SLN Series

SX Series

Extended Super-LED corner modules.

SP Series

Extra high intensity extended Super-LED corner modules.

SLN Series

Lightbars meeting new NFPA 1901 Lighting Standards having been approved and certified to all SAE testing requirements and specifications by AAMVA or its successor AMECA. Two 54" models available SLN2VLED and SLN2QLED.

- Scan-Lock™ allows you to scan through multiple flash patterns and lock in the desired pattern. Every pair of lights can have its own unique pattern.
- Optional five or six LED Traffic Advisor with ultra high intensity Linear-LED modules or five or six split Traffic Advisor with passenger side warning alternates with driver side warning.
- Low "LC" current operation uses a small diameter external cable harness for operation with standard or low current switch controls or micro switches.
- Customer installed upgrade kits available to convert SL versions to SX models.

SCANLOCK

Actual height of LFL Liberty lightbar

SCANLOCK

(PATENTED)

At any time easily scan through 21 flash patterns and lock in the one you want.

- CometFlash® 150 - Alternating
- CometFlash 150 - Simultaneous
- CometFlash 150 - California
- DoubleFlash 240 - Alternating
- DoubleFlash 240 - Simultaneous
- DoubleFlash 120 - Alternating
- DoubleFlash 120 - Simultaneous
- SingleFlash 375 - Alternating
- SingleFlash 375 - Simultaneous
- SingleFlash 150 - Alternating
- SingleFlash 150 - Simultaneous
- SingleFlash 75 - Alternating
- SingleFlash 75 - Simultaneous
- SignalAlert™ 150 - Alternating
- SignalAlert 150 - Simultaneous
- ActionFlash™ - Alternating
- ActionFlash - Alt. / Sim.
- ActionFlash - Simultaneous
- ModuFlash™ - Alternating
- ModuFlash - Simultaneous
- ActionScan



Liberty lightbars turned off have the stealth look, while when turned on provide a very bright directional warning signal.

LIGHTBARS



WE CAN



Optional WeCan Controller WCC9

SW & SR Series WeCan® Programmable Lightbar Series.

Similar to the SX/SP Series but includes an external interface unit, the WeCan electronic control module (ECM), which communicates all lightbar operating functions via a 2 conductor, 20 gauge cable. All functions are programmed via simple "pick & click, or drag" screens. Windows® based 2000, XP or later operating system required. USB input to the ECM from PC or laptop makes programming easy. Available with a 10 dip switch selectable switching configuration with optional 6 push button and 4 position slide switch WeCan Model WCC9 Control Head.

SW Series

Extended Super-LED corner modules.

SR Series

Extra high intensity extended Super-LED corner modules.

- Small cable allows for easier overall wiring and lightbar installation.
- **NEW Duo™** technology modules for combination Traffic Advisor and warning capability in a single lighthouse.
- Up to eighteen different programmed warning configurations can be operated via customer supplied switching to each of only eighteen input wires to the ECM (default program pre-installed). Once the ECM is programmed, selection of these wires will allow for:
 - Complete independent "On" or "Off", as well as, flash pattern control of each lighthouse.
 - Phase control of each lighthouse, with four phases that allow for alternating, simultaneous & combo flash patterns.
 - Cruise light control with multiple adjustable intensity levels.
 - Independent Hi/Low control is available to any one or more Super-LED lighthouses, excluding the four corner modules (required for SAE certification). Now available as a Photocell Hi/Low option.
 - Independent (sequential) or 2-wire control of the traffic arrow functions (left, right, split, and does not require a Traffic Advisor control head).

Dimensions

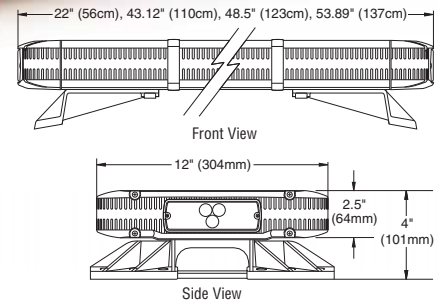

Mini Liberty LT2 Series

State-of-the-art optics in a 22" Length.

- Four Linear Super-LED modules and LED flasher.
- Available in magnetic or permanent mount.
- Permanent mount with 15' passenger side cable and optional halogen take-down, and/or two halogen alley lights.

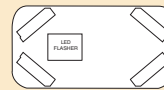

Proud to be an American! The LFL Liberty lightbar, is proudly designed, manufactured and assembled in America.

All LFL Liberty Lightbars Offer Modular Design.

1 End modules slide in channels of the aluminum housing. 2 All inboard warning lighthouse modules are easy to access and are the same size and can be placed anywhere in the lightbar. 3 Modules snap-in for a tight secure fit. 4 Connectors snap together for easy lighthouse replacement or additions.



Standard Configuration

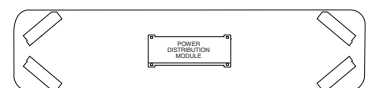

LEGEND

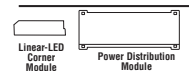

LFL LIBERTY™ LIGHTBAR OPTIONS

To help you build your LFL Liberty Lightbar, Whelen "WeCad™" build-a-bar program is available on our Website at:

www.whelen.com

Options	Mini Options	SX & SLN† Models			SP Models			WeCan SW Models			WeCan SR Models			Mini Models	
		SX4***	SX8***	SX2***	SP4***	SP8***	SP2***	SW4***	SW8***	SW2***	SR4***	SR8***	SR2***	LT2****P	LT2****M
LFL LIBERTY OPTIONS															
Two halogen alley lights, for LT2****P Only	-	LTALY	-	-	-	-	-	-	-	-	-	-	-	-	✓
One front facing halogen take-down light, for LT2****P Only	-	LTTD1	-	-	-	-	-	-	-	-	-	-	-	-	✓
Two inboard Super-LED® directional lighthoods	SLD**	-	✓	✓	✓	✓	✓	✓	✓	✓	✓	✓	✓	✓	-
Two super high intensity LED work lights	SXWLED	-	✓	✓	✓	✓	✓	✓	✓	✓	✓	✓	✓	✓	-
Two super high intensity LED take-down lights	SXTDLED	-	✓	✓	✓	✓	✓	✓	✓	✓	✓	✓	✓	✓	-
Two LR11 Super-LED flashing take-down lights	SXTLS1	-	✓	✓	✓	✓	✓	✓	✓	✓	✓	✓	✓	✓	-
Two Dual LR11 Super-LED flashing take-down lights	SXTLS1D	-	✓	✓	✓	✓	✓	✓	✓	✓	✓	✓	✓	✓	-
Two LR11 Super-LED flashing take-down lights and one Linear-LED, center option only, clear outer lens	SXTLS1M*	-	✓	✓	✓	✓	✓	✓	✓	✓	✓	✓	✓	✓	-
Two LR11 Super-LED flashing take-down lights and installation of 795H (795H purchased separately), center mount option only, when purchased with Liberty lightbars	SX795HLR	-	✓	✓	✓	✓	✓	✓	✓	✓	✓	✓	✓	✓	-
Two LR11 Super-LED flashing lights (red/blue and/or amber) and installation of 795H (795H purchased separately), center mount option only, when purchased with Liberty lightbars	SX795**	-	✓	✓	✓	✓	✓	✓	✓	✓	✓	✓	✓	✓	-
NEW! Two LR11 Super-LED flashing alley lights with 15° horizontal adj. for Liberty Series without screw holes on the top, SW & SR models only.	SRALF1	-	-	-	-	-	-	✓	✓	✓	✓	✓	✓	✓	-
NEW! Two LR11 Super-LED flashing alley lights with 15° horizontal adj. for Liberty Series without screw holes on the top, SP, SX, SL models only.	SPALF1	-	✓	✓	✓	✓	✓	✓	✓	✓	✓	✓	✓	✓	-
Two LED brake/tail/turn lights (SW Series only, No SX Series)	SWBTTLED	-	-	-	-	-	-	✓	✓	✓	✓	✓	✓	✓	-
Five Linear-LED Traffic Advisor™, requires no special control head	SLTALN5L	-	✓	✓	✓	✓	✓	✓	✓	✓	✓	✓	✓	✓	-
Six Linear-LED Traffic Advisor, requires no special control head	SLTALN6L	-	-	✓	✓	✓	✓	✓	✓	✓	✓	✓	✓	✓	-
Five Linear Super-LED Traffic Advisor, includes control head, for SX Series only, do not use on SW Series	SLTALN5	-	✓	-	-	-	-	-	-	-	-	-	-	-	-
Six Linear Super-LED Traffic Advisor, includes control head, for SX Series only, do not use on SW Series	SLTALN6	-	-	✓	✓	-	-	-	-	-	-	-	-	-	-
Solar Panel to reduce parasitic draw for LC (low current) lightbars with passenger side cable exit	SOLARPNL	-	✓	✓	✓	✓	✓	✓	✓	✓	✓	✓	✓	✓	-
Solar Panel to reduce parasitic draw for WeCan™ lightbars with passenger side cable exit	SOLARPWC	-	-	-	-	-	-	✓	✓	✓	✓	✓	✓	✓	-
Five Linear Super-LED Split Traffic Advisor™, requires no special control head, replace symbol "S" with number of split warning LED Colors, Order is Red/Blue/Amber, 5 Max. For SW Series Only	SWW\$\$\$00	-	-	-	-	-	-	✓	✓	✓	✓	✓	✓	✓	-
Five Linear Super-LED Split Traffic Advisor, requires no special control head, driver side warning lights alternates with pass. side warning lights, no individual control of rear inboard warning for SX Series Only	SLW\$\$\$00	-	✓	✓	✓	-	-	-	-	-	-	-	-	-	-
Six Linear Super-LED Split Traffic Advisor, requires no special control head, driver side warning lights alternates with pass. side warning lights, no individual control of rear inboard warning for SX Series Only	SLX\$\$\$00	-	✓	✓	✓	-	-	-	-	-	-	-	-	-	-
Five Linear Super-LED Split Traffic Advisor, includes control head, for SX Series only, do not use on SW Series	SLY\$\$\$00	-	✓	✓	✓	-	-	-	-	-	-	-	-	-	-
Six Linear Super-LED Split Traffic Advisor, includes control head, for SX Series only, do not use on SW Series	SLZ\$\$\$00	-	✓	✓	✓	-	-	-	-	-	-	-	-	-	-
Six Linear Super-LED Split Traffic Advisor, requires no special control head, for SW Series only	SWX\$\$\$00	-	-	-	-	-	-	✓	✓	✓	✓	✓	✓	✓	-
NEW! Five Duo™ color Linear Super-LED Traffic Advisor, requires no special control head, for WeCan models only	SPY\$\$\$00	-	-	-	-	-	-	✓	✓	✓	✓	✓	✓	✓	-
NEW! Six Duo™ color Linear Super-LED Traffic Advisor, requires no special control head, for WeCan models only	SPZ\$\$\$00	-	-	-	-	-	-	✓	✓	✓	✓	✓	✓	✓	-
Delete TACTALD1 from 6-8 light LED Traffic Advisor™	DELTALD1	-	✓	✓	✓	✓	✓	✓	✓	✓	✓	✓	✓	✓	-
Criss/cross flash pattern of end Linear-LED's, for SX Series only, do not use on SW Series	SLXXPAT	-	✓	✓	✓	✓	✓	✓	✓	✓	✓	✓	✓	✓	-
Driver side cable exit, includes 20' power cable & control cable, for SW series only, do not use on SX/SP Series	SWDSCBL	-	-	-	-	-	-	✓	✓	✓	✓	✓	✓	✓	-
Driver side cable exit, includes 25' power and ground cable, for SX Series only, do not use on SW/SR Series	SLDSCBL	-	✓	✓	✓	✓	✓	✓	✓	✓	✓	✓	✓	✓	-
Quick Disconnect Plug for WeCan Lightbars Only	WCQDPLUG	-	-	-	-	-	-	✓	✓	✓	✓	✓	✓	✓	-
Upgrade kit to convert SL into a SX Series lightbar, with 4 extended corners, 4 blue, red and/or amber	SXKT****	-	✓	✓	✓	✓	✓	✓	✓	✓	✓	✓	✓	✓	-
NEW! Substitute WCC9 WeCan controller for WeCan electronic control point module	WCC9SUB	-	-	-	-	-	-	✓	✓	✓	✓	✓	✓	✓	-
NEW! Photo cell for Hi/Low power	SLPHOTO	-	✓	✓	✓	✓	✓	✓	✓	✓	✓	✓	✓	✓	-



White LR11 Super-LED alley light



High intensity LED work light & LED take-down



Linear-LED for center section

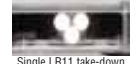

Single LR11 take-down



Dual LR11 take-down



Two LR11 flashing take-down lights & one Linear-LED for center section



Solar panel



LED brake/tail/turn



Lighted sign



Six panel split Traffic Advisor

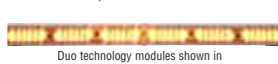

Six panel Traffic Advisor



Duo technology modules shown in amber Traffic Advisor mode and in red/blue warning mode



WCC9 WeCan controller, SW/SR only



Whelen products are proudly made in the U.S.A.

The selection of one option may preclude the selection of another option. See the latest Price List for complete listing and descriptions of Models & Options.

† For SLN Series NFPA Lightbar options, contact factory.

LEGEND: * = Replace * in model number with lens color desired: A=Amber; B=Blue; C=Clear; G=Green; R=Red

§ = Replace symbols with number of colored LED lighthoods required (maximum 12 modules).

Order of colors in Model Number are Red, Blue, Amber and White. Use X=12, Y=11 & Z=10.

i.e. SLD2222 = 2 Red, 2 Blue, 2 Amber & 2 White, SLD02020 = 0 Red, 10 Blue, 0 Amber & 2 White.



51 Winthrop Road, Chester, CT 06412-0684
860-526-9504 • Fax 860-526-4078
www.whelen.com