

NEW PRODUCT

8" Round Interior Light

SUPER-LED® AMBULANCE INTERIOR LIGHTHEAD

LIGHTHEADS

Simulates natural light at mid-day for truer flesh tones and accurate patient evaluation. White lighthouse feature Hi/Low intensity mode standard.

FEATURES

- Long life performance.
- Direct replacement to outdated halogen and incandescent lighting fixtures.
- Eliminates the high cost of lamp replacement associated with halogen or incandescent lamps.
- Lower interior ambient operating temperature than halogen or incandescent fixtures.
- Conformal coating provides moisture and vibration resistance.
- Standard 6" pigtail.
- Certified to meet KKK-1822F requirements when properly installed.
- Hi/Low intensity standard.
- Lighthouse can be PWM (Pulse With Modulation) from an electrical control system for additional intensity levels.
- Low amperage consumption: 1.5 amps High, .15mA Low@12.8 VDC.
- White lighthouses offer 950 lumen output.
- Five year HDP® (Heavy-Duty Professional) warranty.
- Red interior light for the vehicle cab.
- White has hi/low intensity levels for improved running nighttime vision.
- **NEW** Models with spring clip mounting require no mounting hardware for installation.



MODELS

- 80C0EHCR:** ...18 Diode interior light, White
- 80C00EZR:** ...18 Diode, 8" cutout, no mounting hardware required, Chrome housing
- 8WC00EZR:** ...18 Diode, 8" cutout, no mounting hardware required, White housing
- 80CBEHCR:** ...9 Diode, 6 White with Hi/Low and 3 Blue
- 80CREHCR:** ...9 Diode, 6 White with Hi/Low and 3 Red

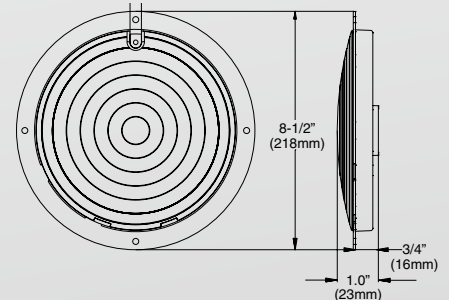

Whelen Engineering reserves the right to upgrade and improve products without notice.
© 2013 Whelen Engineering Company, Inc. Printed in U.S.A.
NASCAR® is a registered trademark of the National Association for Stock Car Auto Racing, Inc.
Code No. 12094D - 06/13



WHELEN®
ENGINEERING COMPANY, INC.

51 Winthrop Road
Chester, Connecticut 06412-0684
(860) 526-9504 • Fax: (860) 526-4078
www.whelen.com