

NEW PRODUCT - PRELIMINARY BULLETIN

Vertex™ Competitor™ Series

SUPER-LED® LIGHTHEAD

LIGHTHEADS



Tiny, cost-effective self-contained lighthead ideal for applications where space is limited.

A cost effective Hideaway™ style light-head requiring only a one inch hole in any composite lighthead, cornering or taillight assembly, or surface mounted to exterior surfaces anywhere on your vehicle.



Shown with optional black flange

Supplied with 6" pigtail

FEATURES

- Economically priced, 3-diode Super-LED Vertex™ with electronics built into base.
- Self-contained, hemispheric LED light for surface mount anywhere on your vehicle, or internal mounting inside of composite headlight, cornering lights and taillight assemblies.
- SmartLED®, requires no external flasher.
- 25 Scan-Lock™ flash patterns.
- Omni-directional, mounts in any position.
- Optimum light distribution achieved with Whelen's unique lens technology.
- Fully encapsulated for moisture and vibration resistance.
- 6-inch wire pigtail, standard.
- Simple installation via two screws in base, no drivers, flashers, ballasts or power supplies to add.
- Optional black or chrome flange kits.
- Available in red, blue, amber and white.

MODEL

VTC3*.....Red, blue, amber or white

OPTIONS

VTCFB:.....Flange kit, surface mount, black

VTCFC:.....Flange kit, surface mount, chrome

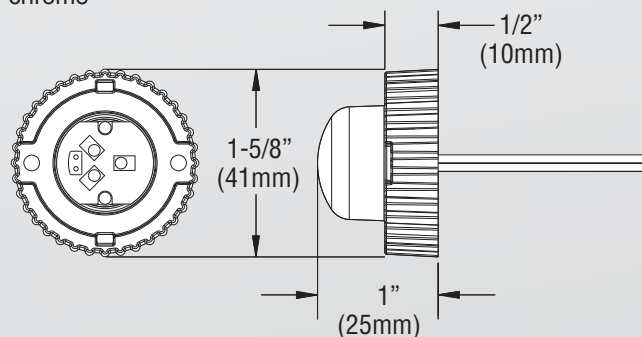

Whelen Engineering reserves the right to upgrade and improve products without notice.
© 2011 Whelen Engineering Company, Inc. Printed in U.S.A.
NASCAR® is a registered trademark of the National Association for Stock Car Auto Racing, Inc.
Code No. 12527A - 10/11

WHELEN®
ENGINEERING COMPANY, INC.

51 Winthrop Road
Chester, Connecticut 06412-0684
(860) 526-9504 • Fax: (860) 526-4078
www.whelen.com