

Model 7090502 LED Anti-Collision Light

For Rotorcraft



SPECIFICATIONS*

Lamp:

LED (Light Emitting Diode)

Input Voltage:

28 VDC

Input Current:

0.4 Amps Average

LED Color:

Aviation Red

Approx. Life:

20,000 Hours

Weight:

1.2 Lbs.

Model Number:

7090502

Part Number:

01-0770905-02

Whelen Aviation Division is proud to announce the introduction of Model 7090502 LED Anti-Collision Lights to its family of aviation safety lighting products.

The 7090502 is designed as a high quality, long lasting, modern alternative to existing anti-collision lights. Also, the 7090502 offers significant technological upgrades over previous products. Utilizing LED (Light Emitting Diode) technology, Whelen is able to provide the following advantages which significantly **reduce operating costs**.

FEATURES

- **Long Life** - The solid-state LED light source has shown conservative lab life results of greater than 20,000 hours
- **Vibration Resistant** - There are three distinct benefits
 - a) The LED light source does not have a fragile filament like a lamp, or a gas filled glass envelope like a strobe flash tube
 - b) There are no heavy capacitors or transformers associated with strobe power supplies
 - c) The hardcoated polycarbonate dome is a simple non-optic part that is molded in one piece. It will not have any molded in stress associated with the two part optic dome. Also the one-piece construction makes it much less susceptible to environmental or chemical breakdown
- **RFI** - No EMI or RFI
- **Lower Power** - Average current draw is 0.4 Amps @ 28V. No inrush current that is inherent with strobe power supplies and halogen flashers
- **Less Weight** - The combined weight of two 7090502 LED beacons is less than the combined weight of strobe power supply, and two strobe beacons
- **Visibility** - The LED approach yields the "best of both worlds". Crisp on and off cycles compared to a halogen or rotor, and longer on time compared to a strobe
- **Reflection** - Will not produce the same reflections as strobe. If needed, the inside of the lens can be masked
- **Mounting** - Units will mount using existing mounting configuration without altering aircraft
- **Quality & Mfg.** - Whelen manufactures and packages all LED products at their facility eliminating costly handling and shipping for different mfg. processes. Utilizing automated machinery for the high volume automotive division, the aviation division is able to capitalize on cost effective mfg. techniques for low volume aviation product runs
- **FAA TSO-C96a** - Approved

WHELEN®

Route 145, Winthrop Road
 Chester, CT 06412
 (860) 526-9504 • Fax: (860) 526-2009
 email: aviation@whelen.com
 Website: www.whelen.com



*Designed &
 Manufactured
 in the U.S.A.*

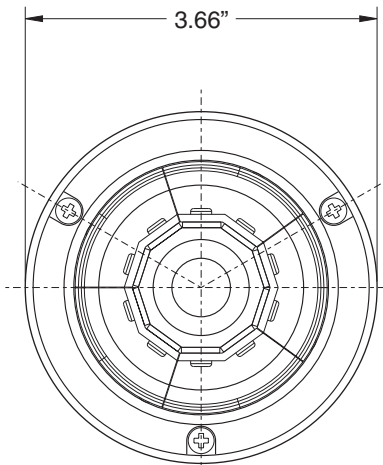

4x#6-32 MTG HOLES
EQUALLY SPACED ON
A 1.625" BOLT CIRCLE

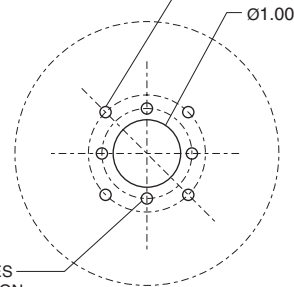

4x#6-32 MTG HOLES
EQUALLY SPACED ON
A 1.250" BOLT CIRCLE

MODEL 7090502
SUGGESTED MOUNTING HOLE PATTERN

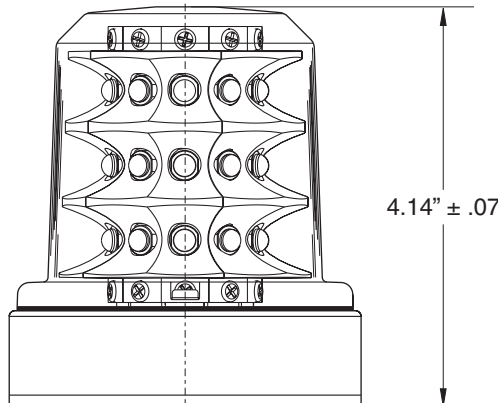

NOTES:

1. Model 7090502 Specifications:

Input Voltage: 28VDC

Input Current: 0.4 Amps Average

Led Color: Aviation Red

Lens: Clear Polycarbonate

Flashrate: 45±5 Per Min.

Weight: 1.2 Lbs.

2. Units meet the minimum requirements stated in FAR Parts 27 & 29 for anti-collision light systems used on Rotocraft.

*Ref; Class I (150 Candela Effective Intensity) of SAE as 8017a Minimum Performance Standards.

3. FAA TSO-C96a Approved

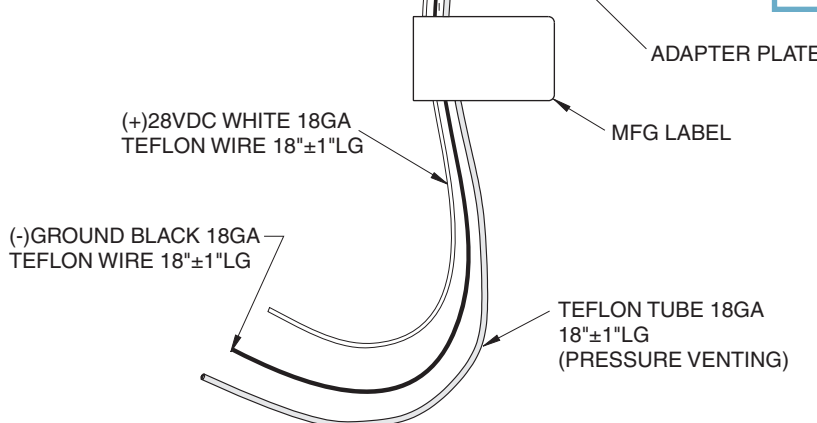

WHELEN[®]

Route 145, Winthrop Road
Chester, CT 06412
(860) 526-9504 • Fax: (860) 526-2009
email: aviation@whelen.com
Website: www.whelen.com

