

WHELEN[®]
ENGINEERING COMPANY INC.

51 Winthrop Road

Chester, Connecticut 06412-0684

Phone: (800) 63SIREN

Phone: (860) 526-9504

Fax: (860) 526-4784

Internet: www.whelen.com

Sales e-mail: iowsales@whelen.com

Customer Service e-mail: iowserv@whelen.com

**WPS-2900 SERIES
HIGH POWER VOICE
& SIREN SYSTEM**

**OPERATING & TROUBLESHOOTING
MANUAL**

Mass Notification

Table Of Contents

Section I:	Overview of System Components	
	a) Station Component Locations.....	page 5
	b) Station Components Defined	page 6
Section II:	System Operations	
	a) Remote Operations	page 9
	b) Local Operations	page 9
Section III:	Understanding Station Addressing	
	Central Point Source.....	page 11
	Governmental.....	page 17
Section IV:	Troubleshooting	
	Audio Loss	page 18
	Solar Regulator	page 19
	AC Battery Charger.....	page 19
	Digital Voice.....	page 21
	Partial or Full Diagnostic Failure.....	page 21
Section V:	System Maintenance	
	Frequency of Testing and Activation.....	page 22
	Quarterly Maintenance	page 23
	Visual Siren Station Inspection	page 24
	Siren Cabinet and Components	page 24
	Speaker Assembly and Pole Top Equipment.....	page 24
	Station Performance Testing	page 25
	Maintenance Check List.....	page 27

Illustrations

Fig. 1a:	Station Wiring Diagram (designations).....	page 3
Fig. 1b:	Station Wiring Diagram (voltages).....	page 4
Fig. 2:	Siren Cabinet Door Components	page 5
Fig. 3:	Station Control Panel	page 10
Fig. 4:	Central Point Source Divisions	page 11
Fig. 5:	Single Station Selection	page 12
Fig. 6:	Group Selection - Radial Sector	page 13
Fig. 7:	Group Selection - Sub Sector	page 14
Fig. 8:	Group Selection - Quadrant	page 15
Fig. 9:	Group Selection - All-Call	page 16
Fig. 10:	Solar Regulator Connector Pin-Outs	page 20
Fig. 11:	System LED Diagnostic Indicators	page 29
Fig. 12:	Control Board Wire Colors	page 30

IMPORTANT! THIS MANUAL ASSUMES THE READER/TECHNICIAN HAS AN INTERMEDIATE TO ADVANCED LEVEL OF PROFESSIONAL TRAINING IN THE FIELD OF ELECTRONICS.

Fig. 1a: Station Wiring Diagram (designations)

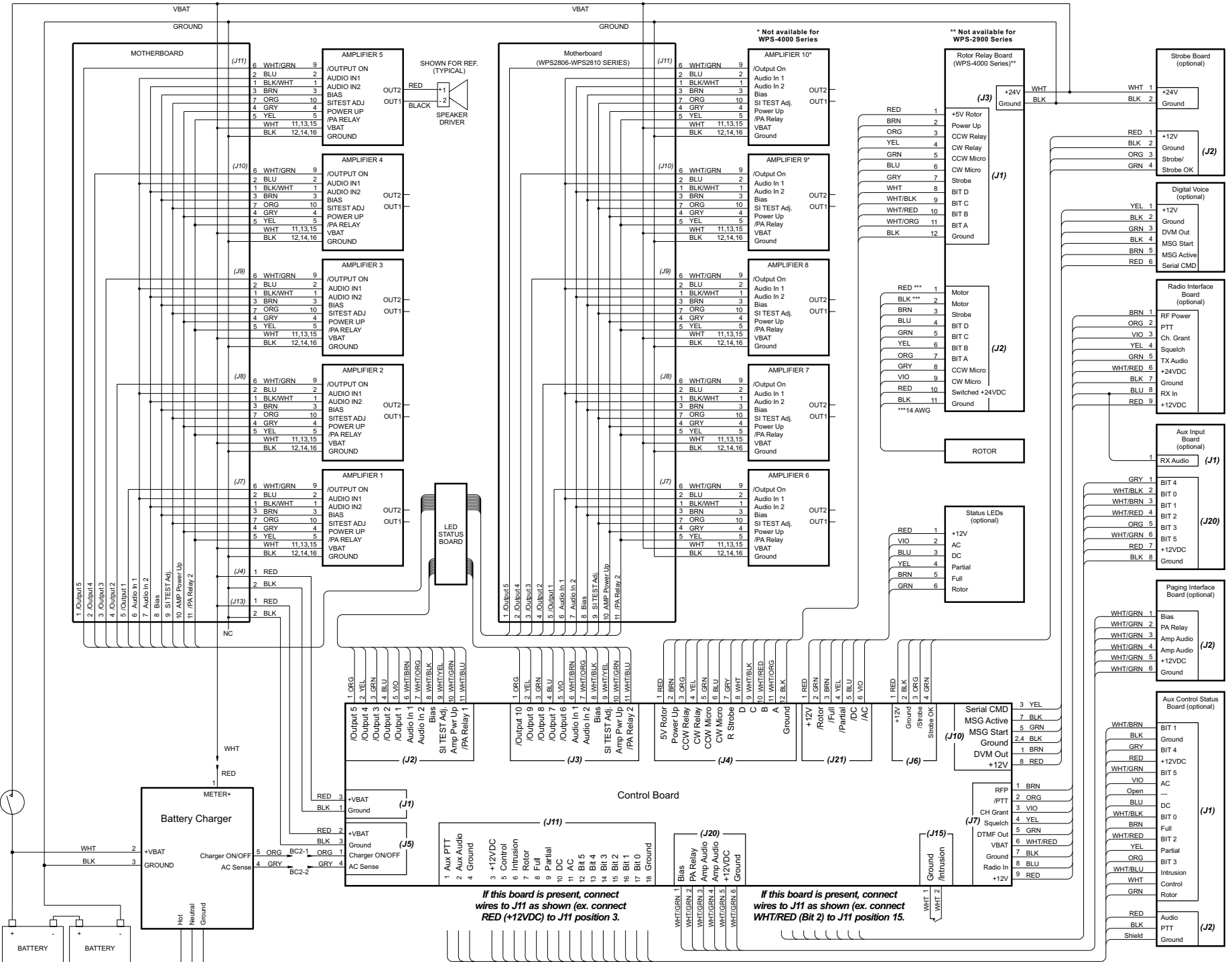

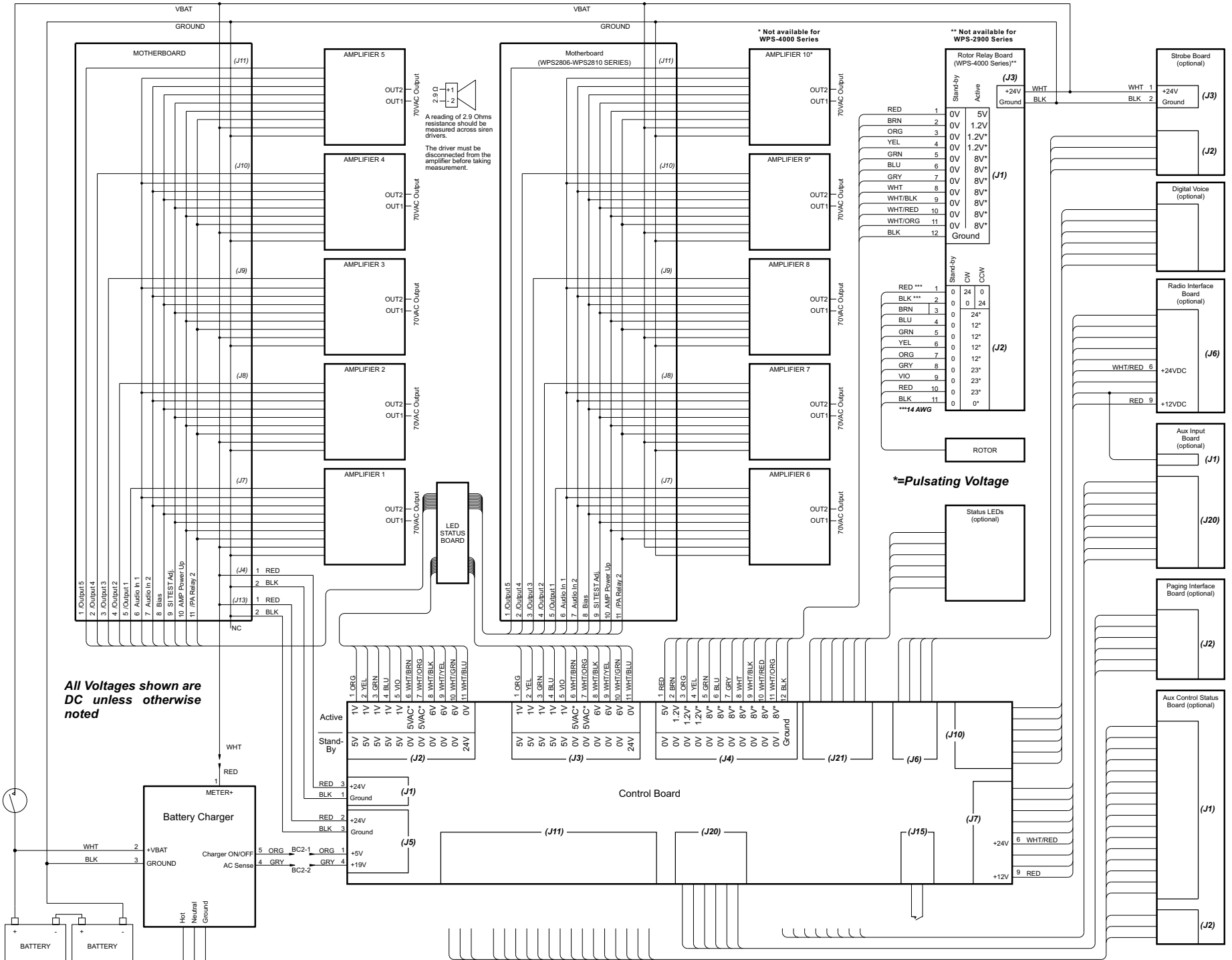

Fig. 1b: Station Wiring Diagram (voltages)

Section I: Overview of System Components

a) Station Component Locations

The WPS-2900 High-Power Voice and Siren System is comprised of 10 basic models:

<u>Model</u>	<u>Driver Info</u>	<u>Cabinet</u>
WPS-2900-1	One (1), 400 Watt Driver	Type II
WPS-2900-2	Two (2), 400 Watt Drivers	Type II
WPS-2900-3	Three (3), 400 Watt Drivers	Type II
WPS-2900-4	Four (4), 400 Watt Drivers	Type II
WPS-2900-5	Five (5), 400 Watt Drivers	Type II
WPS-2900-6	Six (6), 400 Watt Drivers	Type II
WPS-2900-6A	Six (6), 400 Watt Drivers	Type III
WPS-2900-7	Seven (7), 400 Watt Drivers	Type III
WPS-2900-8	Eight (8), 400 Watt Drivers	Type III
WPS-2900-9	Nine (9), 400 Watt Drivers	Type III
WPS-2900-10	Ten (10), 400 Watt Drivers	Type III

Each system essentially functions in the same manner as do the others. This manual will provide the necessary information to properly operate, program and diagnose this system regardless of specific model. If information relevant to a specific model is required, it shall be presented and noted as such.

The 2900 series systems are comprised of several major components common to all models, although quantities of some components will vary from model to model.

Fig. 2: Siren Cabinet Door Components

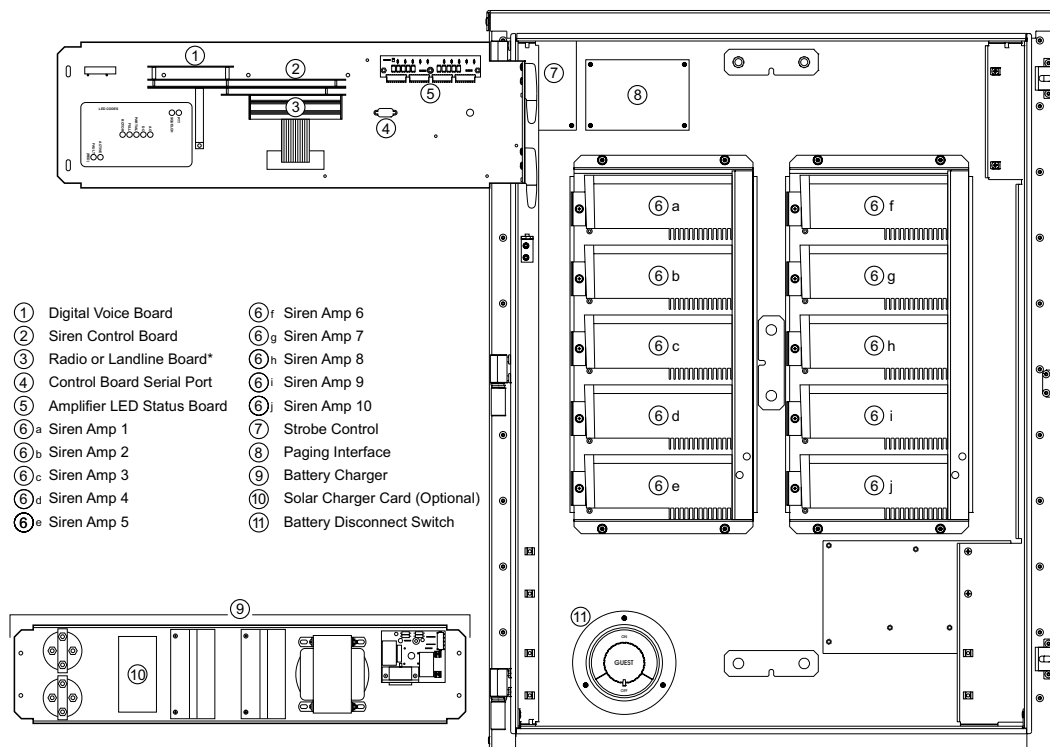

b) Station Components Defined

Control Board - This component (located on the inside of the upper cabinet door) controls the key functions of the WPS2900 system including:

Tone Generation	Remote Activation
Event Timing	Rotor Control
Remote Station Status Reporting* (encoding)	Local Control
System Diagnostics (incl. SI TEST®)	

The control board contains a microphone jack for public address and a serial port to allow connection of our Siren Diagnostic Programming Tool Software (hereafter referred to as SDPTS) to the remote station. The control board is also the location of the diagnostic LED's.

Siren Amps - These components (located on the inside of the upper cabinet door) receive the desired tone or message generated by the control board, amplify it and deliver it to the siren driver.

Siren Driver - This component (located in the speaker assembly) produces the desired audible tone or voice message.

Radio or Landline Board (Optional) - This component (located on the inside of the upper cabinet door) receives signals from either the antenna or landline and delivers them to the control board for processing. Through the use of the included radio, the station is also capable of transmitting status information back to the control center.

Motherboard - This component (located on the inside of the upper cabinet door) distributes Battery Voltage and signals to all system components that require this voltage. The motherboard is fused @10 Amps to protect all connected components EXCEPT for the siren amplifiers and the rotor (they contain their own fuse). The 2nd motherboard (WPS2900-6 thru WPS2900-10) is also fused @10 Amps. The Motherboard also distributes signals between the amplifiers and the control board.

AC Battery Charger - This component (located on the inside of the lower cabinet door) uses 110 VAC (or 220 VAC) single-phase service to maintain the stations batteries at their proper voltages.

Solar Regulator (optional) - This component (located on the inside of the lower cabinet door) uses electrical energy collected by a pole-mounted solar panel to maintain the station batteries at their proper voltages.

Ammeter - This component (located on the inside of the lower cabinet door) provides a visual indication for the charge current flowing into the batteries from the charger or regulator.

Voltmeter - This component (located on the inside of the lower cabinet door) provides a visual indication of the DC voltage across the batteries.

Auxiliary Control Status Board (optional) - This component (located on the right inside wall of the upper cabinet) is wired to remote switches to facilitate remote operation of a specific siren station.

Auxiliary Input Control (optional) - This component (located below the “Radio/Landline Board” on the rear inside wall of the upper cabinet) is wired to remote switches to facilitate limited remote operation of a siren station. In contrast to the Auxiliary Control Status Board, the Auxiliary Input Control Board does not offer feedback capabilities and is limited to the following remote activation commands:

- All Siren Tones
- Cancel
- SI TEST®
- Digital Voice Messages 1 thru 4

Batteries - These components (located on the inside of the lower cabinet) provide the 28VDC necessary for the system to operate.

Battery Disconnect Switch - This component (located on the rear inside wall of the upper cabinet) allows all system batteries to be completely disconnected from the system. NOTE: This switch does not disconnect the batteries from the battery charger or regulator.

Antenna Poly Phaser (optional) - This component suppresses high-voltage (static) charges that could be present on the antenna.

Antenna (optional) - This component (located on the utility pole) is capable of either receiving signals broadcast from the control center (one-way) or can both transmit and receive signals to and from the control center (two-way), depending how the system was ordered.

Solar Panel (optional) - This component (located on the utility pole) collects solar energy, converts it to electrical energy and delivers it to the Solar Regulator to maintain the station batteries at their proper voltage.

Strobe Control Board (optional) - This component (located on the rear inside wall of the upper cabinet) is a user-defined device that controls a pole-mounted strobe light. This light can be configured to activate during specific conditions (example: when any tone or message is generated).

Intrusion Alarm (optional) - This sensor (located on the door jam of the upper cabinet door) detects the opening of the cabinet door. If the station is equipped with this option, the alarm is configured to transmit a signal back to the control center.

Paging Interface (optional) - This component (located below the “Strobe Control Board” on the rear inside wall of the upper cabinet) is a user-defined device that serves as an interface between the siren cabinet and an existing, in-house public address system. This board has an output relay with a 1 Amp rated closure that can be used for a “Push To Talk” function.

Section II: System Operations

a) Remote Operations

Remote operation of a WPS-2900 series siren involves transmitting signals from the control center to the desired station. This is accomplished by using either an encoder and transmitter or, if the station is so equipped, using an auxiliary control status board that has been wired to switches/controls at the control center. Remote operation is beyond the scope of this document and will therefore not be addressed. If your system is equipped with an encoder, please refer to the encoder operating manual for information regarding remote operation. If your station has been wired to use the auxiliary control status board, refer to the reference materials provided by the electrical engineer or installer.

b) Local Operations

Local operation is accomplished through the control panel on the front of the station cabinet. The functions of these controls are as follows:

Cancel	Abruptly stops siren tones without the normal “ramp down” found in several tones. Helpful in the event of an accidental tone activation.
Wail	Produces a slow rise and fall tone.
Attack	Produces a faster rise and fall tone (used for designated Civil Defense National Attack tone).
Alert	A steady tone (Civil Defense alert).
Whoop	A repetitive rise-only tone.
Hi-Low	An alternating two-tone sound.
Air Horn	A pulsing air horn sound.
SI TEST®	Initiates SI TEST® tone and the optional diagnostic SI TEST® routine.
Xmit Carrier	Actuates remote station radio transmitter PTT circuit. When tone squelch is used with the transmitter, the transmit function is used when adjusting tone squelch modulation.

Xmit Audio	For use with remote station radio transceiver, causes transmission of DTMF tone via RF link for tone modulation adjustment.
Xmit Status	Transmits station status information and battery voltage to the control center.
DVM Test	Activates the Digital Voice Message (DVM) assigned to the test procedure in the configuration software.
Rotor CW	No function with 2900-series equipment.
Rotor CCW	No function with 2900-series equipment.
Keypad Arm	Enables local station operation via keypad. Once pressed, the keypad remains active until either a) another keypad button is pressed, or b) 60 seconds have elapsed, whichever comes first. The Keypad Arm button must be pressed each time a keypad button is to be pressed. Note that the Cancel button is always enabled and does not require Keypad Arm to be pressed.

Fig. 3: Station Control Panel

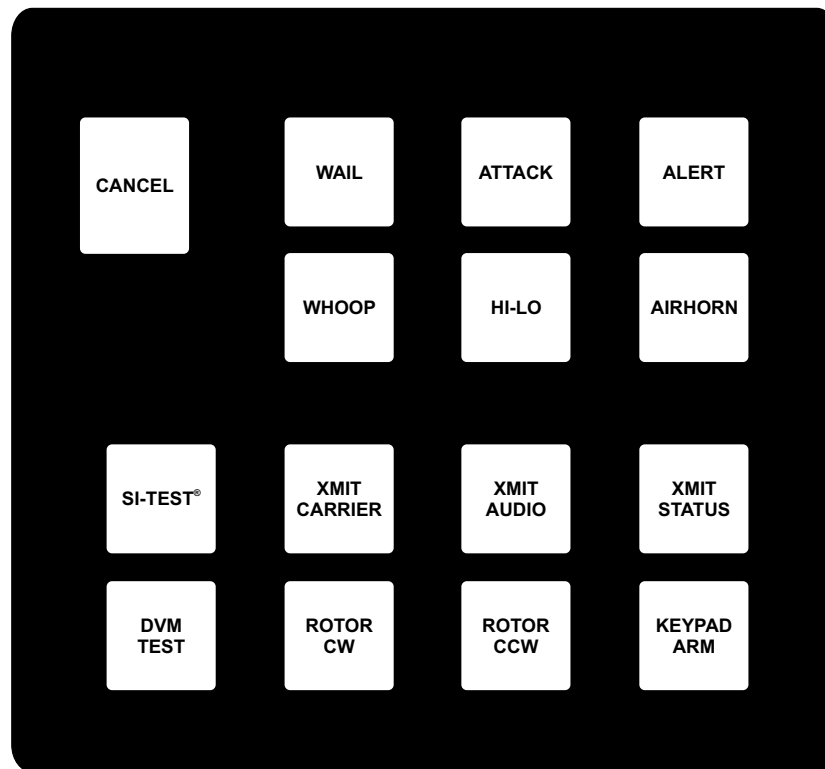

Section III: Understanding Station Addressing

Every Siren Station in a given area code has its own, unique “Station Address”. This address allows the user to select an individual or a group of stations. As stated elsewhere in this manual, a valid station address can be any number from 0000 to 9999. This allows for 10,000 unique addresses; a staggering number of stations to keep track of. Although it is logistically impossible to have that many stations in a single area code, it does illustrate the importance of a sensible, intuitive numbering convention for station addresses. This section will outline two types of conventions

Central Point Source: Quadrant, Sector, Radial & Station

Frequently, warning systems are used to notify the public of emergency situations that may occur from a single, centralized location. Typically, siren stations would be located throughout a 360° area surrounding this location for a specified distance from the source. In this scenario, the Central Point Source convention would be well suited.

For illustration purposes, assume the siren stations are installed within a 5 mile radius of the Central Point. As such, a Quadrant, Sector, Radial & Station numbering convention would allow the selection of any of the following:

- any siren station
- all siren stations
- any one of four sectors
- any one of 5 radii within the sectors

The area of coverage in this system, a circle, is divided into 4 quadrants. Each quadrant is then divided into 4 sectors. Each sector is further divided into 5 segments or radii emanating from the center of this siren system.

Fig. 4:
Central Point
Source Divisions

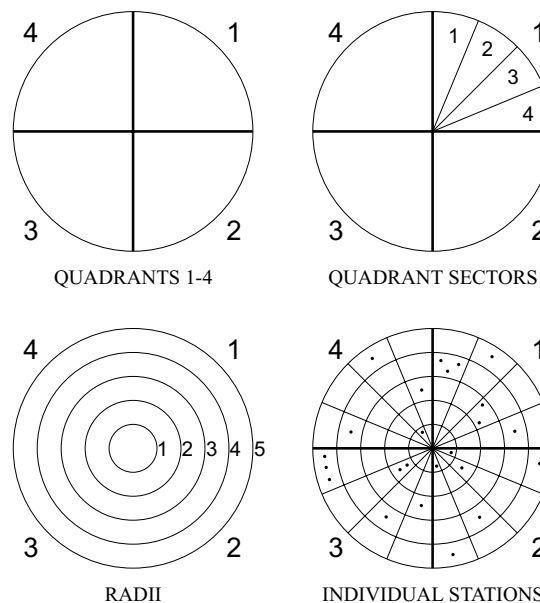

In this system, a stations address is structured as follows:

<u>Digit</u>	<u>Allocation</u>
1	Quadrant (1 to 4)
2	Sector (1 to 4)
3	Radii (1 to 5)
4	Individual station within a radian

Here are some sample activations to further illustrate this concept.

Sample 1:

A station with address 1354 would be located in:

Quadrant: 1
Sector: 3 of Quadrant 1
Radial: 5
Station: 4

If an operator selects station 1-3-5-4, only that station will be selected, as shown.

Fig. 5:
Single Station Selection

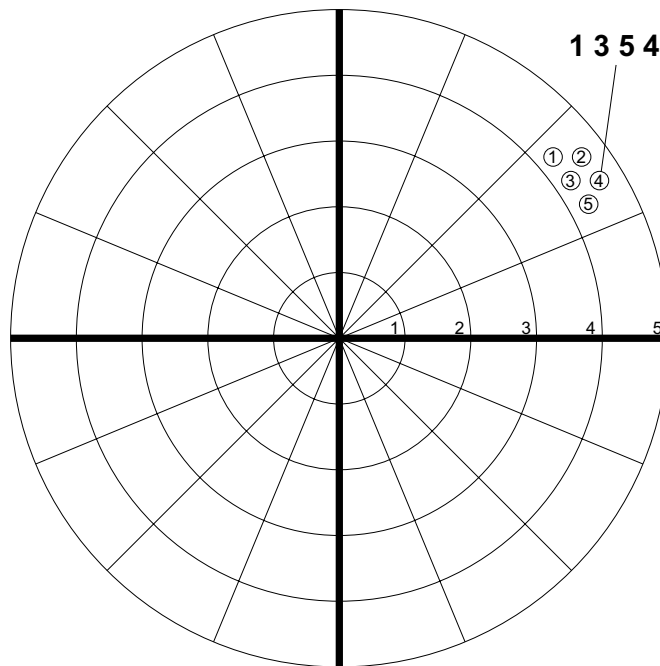

**SINGLE STATION SELECTION
STATION 1354**

Sample 2:

If the activation of a group of remote stations within a whole segment of a radius within a quadrant and sector is desired, the fourth digit address is substituted with a “Wild Card”, the “#” pound sign.

An address selection of 1 - 3 - 4 - # would activate the system as follows:

- Quadrant:** 1
- Sector:** 3 of Quadrant 1
- Radial:** 4
- Station:** # All stations defined by above

This selection is shown below.

Fig. 6:
Group Selection -
Radial Sector

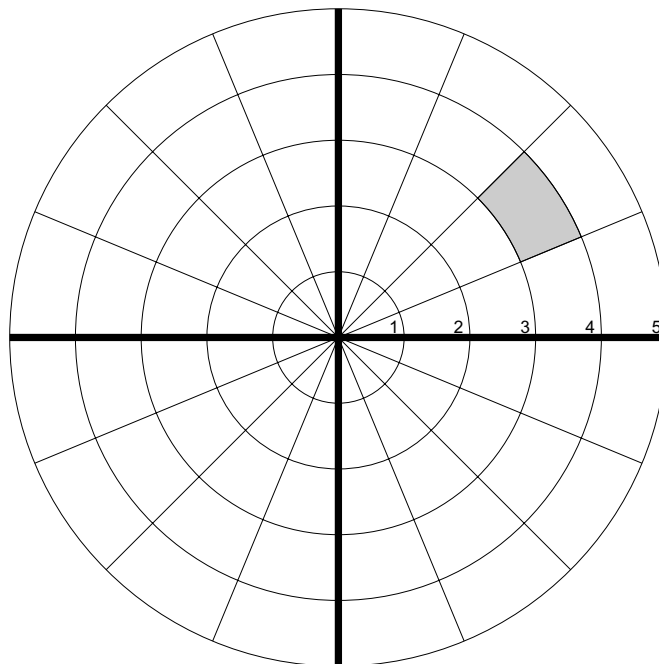

GROUP SELECTION-RADIAL SECTOR
GROUP 134#

Sample 3:

Selection of an entire sector can be accomplished by using the following address:

- Quadrant:** 1
- Sector:** 3 of Quadrant 1
- Radial:** # All radial 1 - 3
- Station:** # All stations defined by above

In selecting a sector, the first two digits of the address are set for the sector address, for example 1 - 3 (Quadrant 1 - Sector 3). The third and fourth digits are substituted with a # (Wild Card). Therefore, the address to select all stations in sector 1-3 is 1 - 3 - # - #. This selection is represented below.

Fig. 7:
Group Selection -
Sub Sector

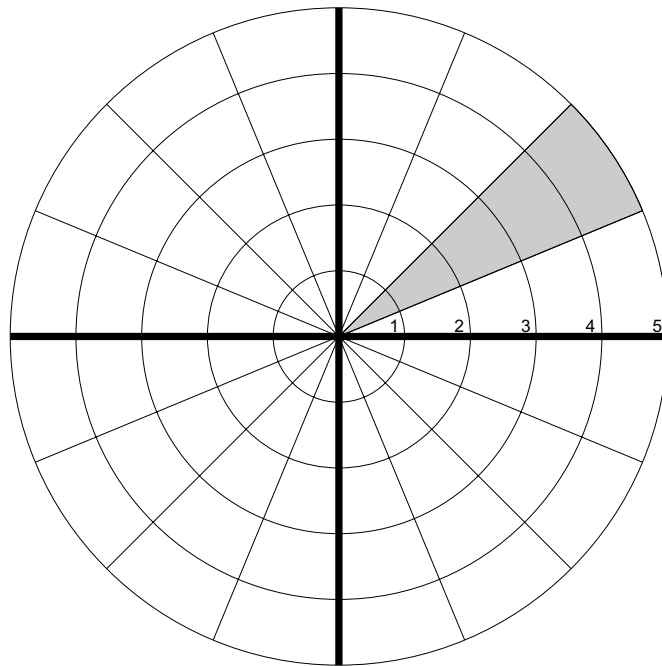

GROUP SELECTION-SUB-SECTOR
GROUP13##

Sample 4:

The selection of a complete quadrant can be achieved by using the following address:

- Quadrant:** 1
- Sector:** # All sectors of Quadrant 1
- Radial:** # All radials in all sectors of Quadrant 1
- Station:** # All stations defined by above

When selecting a quadrant, the first digit designates the Quadrant (1). the second, third and fourth digits are replaced with Wild Cards (#,#,#). Therefore, the address for selecting all stations in quadrant 1 is 1 - # - # - # as illustrated below.

Fig. 8:
Group Selection -
Quadrant

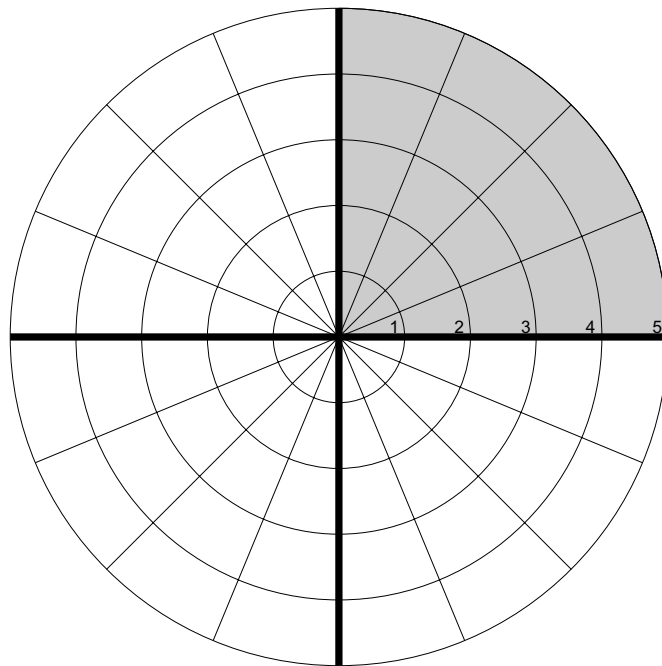

GROUP SELECTION-QUADRANT
GROUP###

Sample 5:

All stations in a system may be accessed by using the Wild Card (#) for all address numbers.
The address would be # - # - # - #.

Quadrant: # All Quadrants

Sector: # All sectors of all Quadrant

Radial: # All radials of all sectors of all Quadrants

Station: # All stations defined by above

This “All Call” is illustrated as shown.

Fig. 9:

**Group Selection -
All-Call**

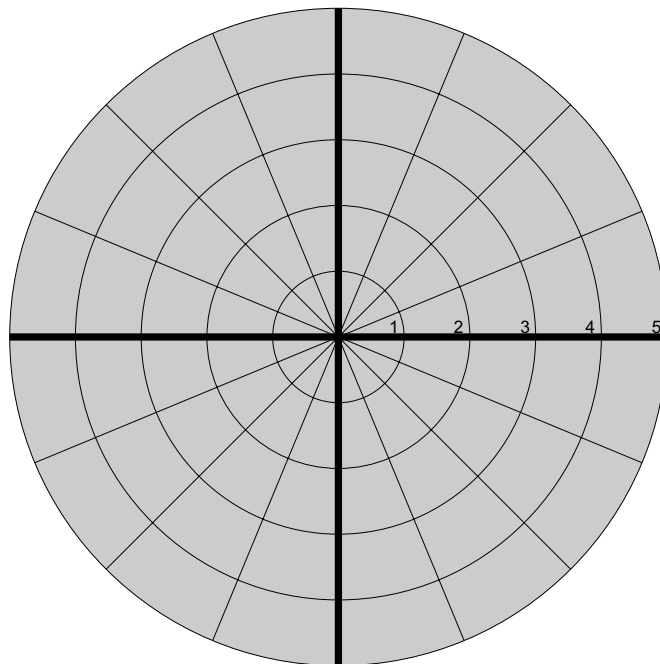

**GROUP SELECTION-“ALL-CALL”
GROUP #####**

Governmental: County, City & Station

For this next type of address structure, assume that the siren system in question is used primarily for tornado warnings throughout a major population center. This center encompasses three counties with each county having no more than ten cities. Two cities contain more than 50 high-power voice and siren stations.

The following represents a Governmental System 4-digit address configuration, allowing activation by “All Call”, county group activations, city group activations and individual station activations:

X	X	X	X	
:	:	:	:	Individual Siren Station (00 - 99)
:	:			
:	:	:	:	City (0 - 9)*
:				
:				County (0 - 9)

*One digit could also be reserved for unincorporated areas.

An address of 2 - 5 - 4 - 5 would indicate the following individual station:

Siren Station 45, in City 5, in County 2.

The Wild Card (#) permits the use of several different types of group activations. Three samples follow:

Sample 1: County Activation (1 - # - # - #)

All Siren Stations in all Cities in County 1 will be activated by this transmission.

Sample 2: City Activation (1 - 5 - # - #)

All Siren Stations in City 5 of County 1 will be activated by this transmission.

Sample 3: System All Call (# - # - # - #)

All Siren Stations in all Cities in all Counties will be activated by this transmission.

Section IV: Troubleshooting

Audio Loss

If after activating the siren there is no audio output, perform the following procedure step by step. This procedure will require a digital multimeter.

- 1. Locate the Audio Presence LED on the controller board (see “Fig. 11: System LED Diagnostic Indicators” on page 29). When audio is present on the board, this LED will be on.**
- 2. Activate the WAIL siren tone from the control panel on the siren cabinet. Confirm that the Audio Presence LED is on. If this LED is not on *or* if it turns off quickly, measure the battery voltage. The siren will not activate if battery voltage drops below 19 VDC. Be sure to measure the battery voltage at the same time you activate the siren. The batteries may show a good float voltage while they are not under load, but upon activation, the battery voltage may drop below 19 VDC if their capacity is low. Note that when the siren shuts down and the load is removed from the batteries, the voltage may rapidly return to 25 VDC or more. If this condition is occurring, the batteries will need to be replaced. If the voltages are in the normal range, proceed to step 3.**
- 3. Locate connector J2 on the control board. With your multimeter set to AC volts, measure across pins 6 and 7 (White with Orange stripe and White with Brown stripe). With the siren tone running, 5 VAC should be present. *If no voltage is present, the controller board is probably at fault.*
NOTE: Confirm that the audio presence LED is on while performing these measurements. It indicates that the siren controller is still activated. If the specified voltages are present, proceed to step 4.**
- 4. With the siren tone still active, measure across pin 1 (Blue wire) and pin 2 (Black w/ White trace) on each of the siren amplifiers. 5 VAC should be present at each amplifier. If so, proceed to step 5. If no voltage is measured, this is indicative of a wiring problem between the controller board and the siren amplifiers. Check the wiring between these components**
- 5. Remove the Red siren driver lead from each siren amplifier. Press “Cancel” on the control panel and then press “Wail”. Measure across the output of each amplifier (White Weco connector) with the siren driver disconnected. 70 VAC should be measured. If this voltage level is measured, proceed to step 6. If this voltage level is not found and 5 VAC was measured at the input, proceed to step 7.**
- 6. Set your meter to measure resistance at its lowest scale. Measure across each of the speaker drivers, making sure that at least one wire of each driver is removed from the power amplifier (or else the transformer in the amp is being measured as well). Each driver should have a DC resistance of approximately 3 Ohms +/- .3 Ohms. If a resistance value outside of this range is found, contact factory.**

7. Set your meter to measure DC Volts. Connect the negative lead of your meter to ground (one of the solid black wires in the multi-position connector on the amplifier is a good ground source). With a siren tone activated, measure the following wires for the following voltages (approximately):

Grey	6 VDC
Brown	5 VDC
Solid White (all)	24 VDC

AC Battery Charger

The AC-powered battery charger has two charging modes: Equalization Mode and Float Charge Mode. The charger is in equalization mode when AC power is first applied; the charger will stay in equalization mode until the battery voltage reaches approximately 30VDC. Once the battery voltage reaches that point, the charger will switch to float voltage mode. In that mode it will charge the batteries to the appropriate voltage relative to the temperature of the batteries (25 to 29VDC).

The AC battery charger contains three circuit boards. The filter board contains a single, green LED, while two charging boards each contain a pair of LED's, one green and one yellow. This pair of LED's provides diagnostic information for the battery charger. The following chart defines their various diagnostic states.

Charging Board	Green LED	Yellow LED
OFF	Not Working	Normal Condition
ON	Charger Operating Properly	Equalization voltage mode
Filter Board		
OFF	No AC voltage present	<i>Not Applicable</i>
ON	AC voltage is present	<i>Not Applicable</i>

Solar Regulator

The following procedure can be performed to confirm proper operation of the solar regulator:

1. Disconnect the solar panel from the charger. With a DC voltmeter, measure the voltage across the wires coming from the solar panel. The voltage should be greater than 32 VDC (NOTE: The solar panel must be in direct sunlight).
2. Reconnect the solar panel to the charger. Monitor the battery voltage with the cabinet voltmeter. The float voltage will vary between 25 to 30 VDC, depending on battery temperature. When the solar regulator is charging, the DC LED on the circuit board will be on. During normal operation the charger will cycle on and off.

The float voltage will vary with battery temperature. The following is a brief description of the normal charging cycle:

If the float voltage for the current temperature of the batteries is 26 VDC, the regulator will turn on at 26 VDC (LED will come on) and it will charge the batteries to 28 VDC. Once the battery voltage reaches 28 VDC, the regulator will turn off (LED will go off), and the battery voltage will be allowed to drop to 26 VDC. The cycle would then repeat itself. If the float voltage was 27 VDC, it would cycle from 27 VDC to 29 VDC.

When AC power is applied to the battery charger, the following voltages should be measured on the wires coming off the charger:

Note: Refer to “Fig. 1a: Station Wiring Diagram (designations)” page 3.

Fig. 10:
Solar Regulator
Connector
Pin-outs

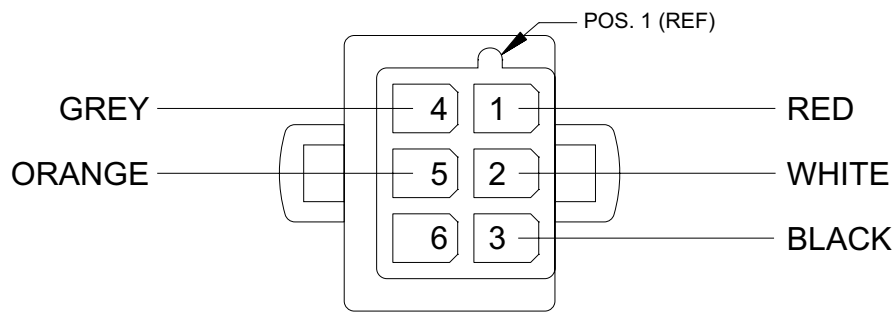

REAR VIEW OF PIN HOUSING

- | | |
|----------------|--|
| Pin Position 1 | RED - Battery Voltage to Ground (BLK wire in BC-1)
Note: Voltage present only when siren is powered up.; this is sourced from the siren motherboard |
| Pin Position 2 | WHITE - Charger output wires (25 to 31 VDC) |
| Pin Position 3 | BLACK - Charger output wires (25 to 31 VDC) |
| Pin Position 4 | GREY - 19VDC from GREY to Ground (BLK wire in BC-1) |
| Pin Position 5 | ORANGE - 5VDC from ORANGE to Ground (BLK wire in BC-1) |
| Pin Position 6 | Not Used |

Digital Voice

1. Remove all amplifier fuses.
2. Install an 8 ohm speaker at amplifier audio input connector pins 1 and 2 (Blue and Black w/White wires) in the 16 position connector.
3. Select a siren tone by pressing one of the controls on the front panel.
4. If the tone can be heard through the speaker, press the DVM-Test control to play the predesignated message.

Partial or Full Diagnostic Failure

This procedure is to be used if the Partial or Full diagnostic LED (located on the controller board) indicates that a problem has been detected. A Partial indication means that at least one speaker and/or amplifier is operational. A Full indication means that all speakers and amplifiers are operational. *NOTE: In order for a good Full indicator to be valid, a good Partial indicator must also be present).*

1. Connect the SDPTS to the siren station *via* the com port on the front of the siren cabinet control panel.
2. Display the “Status” screen on the SDPTS.
3. Press the SI TEST® control on the front control panel.
4. Each amplifier contains a red LED that is visible on the front of the control panel. Note if all the LED’s are on. Tap the “Update Status” button on the SDPTS and note which amp is displaying an error.
5. Open the front panel and swap the speaker driver wires from the amplifier that indicated a failure, with an amplifier with a lit LED. For example: if the LED for amplifier 1 is the only LED not on, install amplifier 1 speaker wires onto amplifier 2 and install amplifier 2 speaker wires onto amplifier 1. This will diagnose if it is the speaker or the amplifier that has failed. You may also measure the DC resistance of the speaker driver with your ohm meter. Be sure that the speaker driver wires are disconnected from the amp prior to measuring. A good driver will read 3 ohms +/- .3 ohms.

Section V: Maintenance

Although The WPS-2900 is of a dependable, solid-state design, periodic activation, field inspection and preventive maintenance is recommended to insure the maximum performance of each station.

Frequency of Testing and Activation

A system of twice-monthly activation and confirmation, combined with a quarterly service and preventive maintenance is recommended to help insure the successful performance of a station. Increasing the frequency of testing will support and improve a station's test record.

Stations located in environmentally adverse locations will require inspection and preventive maintenance at more frequent intervals than just discussed.

IMPORTANT! STATIONS SHOULD ALWAYS BE INSPECTED IMMEDIATELY FOLLOWING SEVERE STORMS.

If a station is activated by remote control (landline or radio), the twice-monthly activation should be performed using the remote control link.

The twice-monthly activation of a station can be confirmed by several different methods, depending upon the options selected with each Whelen System.

Local Site Confirmation

For a basic station activated at the cabinet, or by landline or radio, have an observer confirm that the station activated audibly. The observer should report successful as well as failed station tests. Station Performance Logs should be maintained. It is important to understand that audible confirmation alone is not assurance that the station is operating at 100% power. This requires inspecting the station in greater detail.

Stations may be optionally equipped with counters that advance upon radio or tone generator activation. These counters do not confirm total operation or the final expected output of an outdoor warning device.

If a station is equipped with the "Status Display" option, full power station activation can be visually confirmed from outside the siren cabinet. This diagnostic display, located on the right side of the cabinet, will indicate the following:

(from left to right)

- Red** indicates the presence of AC power (if equipped with an AC Battery Charger)
- Yellow** indicates the presence of DC power at minimum operating level (at least 19VDC)
- Red** indicates partial amplifier/driver function
- Green** indicates full amplifier/driver function
- Red** indicates rotor operation (WPS-4000 systems only)

This diagnostic function is enabled by either a full power siren tone activation or by performing a SI TEST®.

The same information is available on the control board LED numbers 4 - 8. The “Status” option is not required for the on-board LED’s to function.

Following activation and observation, the results should be noted in the performance log. Any indication of incomplete operation presented by the LED indicators should prompt IMMEDIATE service attention.

The system retains diagnostic information until cleared by a specific command.

The diagnostic information stored at the station, if not cleared, will update itself automatically with subsequent SI TEST® or siren tone activations.

Remote Monitoring and Confirmation

Stations equipped with the optional Whelen COMM/STAT™ Command and Status Monitoring control, allow remote monitoring of status as well as confirmation of system activation. COMM/STAT™ returns the results of a remote station activation (both SI TEST® and siren warning mode) in a DTMF encoded format via radio link.

Remote monitoring by RF link eliminates the necessity of physically visiting a station to confirm an activation.

Following the activation of a station, a “Status Request” may be sent to that station by DTMF encoded radio command. Diagnostic information is then presented to the status encoder at the station, converted into DTMF code and transmitted back to the control center, where one of several COMM/STAT™ base station products will convert the DTMF code into meaningful information.

Quarterly Maintenance

Developing a quarterly inspection and preventive maintenance program for an outdoor warning station requires a thorough understanding of all the elements and expectations of the system. The following section provides an overview and basic guideline for quarterly station inspection and preventive maintenance program for the sample station.

Visual Siren Station Physical Inspection

- Observe the speaker cluster, siren cabinet and AC Service for any signs of damage or loose mounting hardware (Some shrinkage of a newly treated utility pole may occur in the first several years following installation, requiring the tightening of mounting hardware).
- Check all conduit for watertight connection and entrance into the siren cabinet.
- Inspect the AC Service for damage, blown fuses, degraded (corroded) power connections and integrity of the lightning arrester.
- Inspect the grounding system for AC Service, Siren Cabinet and pole top equipment. Verify connections and acceptability of earth ground.
- Observe the pole for any shifting and/or leaning. Poles that are not plumb will not properly direct alerting sounds.
- Examine entire station for any signs of vandalism or forced entry.

Siren Cabinet and Components

- Inspect AC Outlet, fuse and surge suppression equipment. Examine system for infiltration of foreign material(s), rodents, insects or other pests.
- Inspect and, if necessary, clean all drain holes and vent screens.
- Inspect battery terminal connections and clean if necessary. Re-apply silicone coating to battery terminals if necessary. Observe battery voltage with siren in inactive state (AC power must be on to station, otherwise station must be powered up to observe meter).
- Examine all wiring harnesses for chafing. Verify wiring terminations for tightness and wiring connections for proper electrical connections. Replace and correct any corroded or marginal connections. Inspect antenna for proper connection.

Speaker Assembly and Pole Top Equipment

NOTE: *Any examination of Pole Top equipment should be performed with the station audibly disabled.*

- Inspect speaker for blockage by rodents, pests, insects or other foreign material. Clean if necessary. Inspect any wiring cables or harnesses for chafing. Inspect the siren driver compartment for infiltration of foreign materials, rodents or pests. Clean if necessary. Confirm that the driver compartment will allow for water or moisture drainage. Inspect speaker wiring connections for any sign of corrosion.

- Verify tightness of all mounting hardware.
- Check all wiring terminations and connections.

Station Performance Testing

NOTE: *Depending on local conditions and station options selected, the station may be tested on or off line. Off line testing of the station involves disconnecting the speaker drivers from the siren amplifiers, so as not to disturb the public when verifying tone generator operation. A complete test must, however, include the testing of the siren amplifier operation. This can be accomplished inaudibly using the SI TEST® command.*

A basic routine, verifying the performance and operation of the sample station previously described, would be as follows:

1. **Local and Remote Activation -**
Activation of each remote station function by local control and remote control. With amplifiers on and off line as needed. An examination of each activation function will also facilitate a verification of related and subsequent system module activations and electrical connections that would be caused by an activation command. Also confirm function time outs (ex.: does the Alert signal time out at three minutes as per user specification?).
2. **Response to Station Address and All Call address programming -**
Control Center reception and activation on SI TEST® or non-tone activation, for individual station address and All Call address selection.
3. **Public Address -**
With the station on line, activation of PA for both local and remote control, verifying PA Audio path and proper set up level of volume.
4. **Siren Amplifiers -**
Inspect for complete operation with speaker drivers (observe LED's).
5. **SI TEST® Station Analysis -**
Observe and confirm diagnostic status of:
AC
DC
Partial Amplifier & Speaker Driver Operation (disable one amplifier to confirm this test).
Full Amplifier & Speaker Driver Operation
NOTE: Verify AC drop out during SI TEST® mode.
6. **Battery Charger Operation -**
Observe for proper charging operation.
Verify AC drop out in PA or SI TEST® mode.

7. **Batteries -**
Verify voltage stability under load.
Perform a load test.

8. **Status Encoder -**
Perform a diagnostic SI TEST® of the station.
Compare status information with observations made locally at the station.
Disable one speaker and verify that the “Full” LED indicator is off.
Disable AC and verify that the “AC” LED indicator is off.
Compare battery voltage return status with observed and measured battery voltage.

9. **Transmitter -**
Check status encoder DTMF tone level modulation with transmitter.

Wide Band		Narrow Band	
With CTCSS	3.1 kHz deviation	With CTCSS	1.8 kHz deviation
Without CTCSS	2.5 kHz deviation	Without CTCSS	1.5 kHz deviation

Check transmitter set up.
Verify power output and SWR.

NOTE:On concluding any examination of a station where connectors have been opened and closed , a final radio test by either SI TEST® or full power should be performed and the results observed for a complete successful test. The PA audio path should also be audibly verified by sending PA and broadcast a voice message.

The following is a sample form that may be used for quarterly inspection and maintenance.

MAINTENANCE CHECK LIST

Station #: _____

Siren Address: _____

Installation Date: ____ / ____ / ____

Inspection Date: _____

Inspector: _____

PHYSICAL INSPECTION:

	<u>OK</u>	<u>NOT OK</u>	<u>COMMENT</u>
Mounting Hardware	_____	_____	_____
Speaker Assembly	_____	_____	_____
AC Service	_____	_____	_____
Proper Grounding	_____	_____	_____
Solar Panels*	_____	_____	_____
Antenna*	_____	_____	_____
Conduit Connections	_____	_____	_____
Siren Case Assembly	_____	_____	_____
Batteries	_____	_____	_____
Components Secure	_____	_____	_____
Harnesses	_____	_____	_____

LOCAL OPERATIONAL TESTING:

Battery Voltage (Stand-by)	_____	_____	_____
Battery Voltage (Under Load)	_____	_____	_____
Manual Test:			
Clear	_____	_____	_____
Wail	_____	_____	_____
Attack	_____	_____	_____
Alert	_____	_____	_____
Airhorn	_____	_____	_____
Hi/Low	_____	_____	_____
Whoop	_____	_____	_____
Clockwise	_____	_____	_____
Counter-Clockwise	_____	_____	_____
SI TEST®	_____	_____	_____
AC LED	_____	_____	_____
DC LED	_____	_____	_____
Partial LED	_____	_____	_____
Full LED	_____	_____	_____
Rotor LED	_____	_____	_____
Timer Set LED	_____	_____	_____
Audio Present LED	_____	_____	_____
Microphone	_____	_____	_____
Mic Volume	_____	_____	_____

*Optional

MAINTENANCE CHECK LIST
(continued)

Radio*:

	<u>OK</u>	<u>NOT OK</u>	<u>COMMENT</u>
Squelch Control	_____	_____	_____
Sensitivity	_____	_____	_____
Antenna Tuned*	_____	_____	_____
Transmit LED	_____	_____	_____
Remote Activation:			
Clear	_____	_____	_____
Wail	_____	_____	_____
Attack	_____	_____	_____
Alert	_____	_____	_____
Public Address	_____	_____	_____
Airhorn	_____	_____	_____
Hi/Low	_____	_____	_____
Whoop	_____	_____	_____
Wail / 5 Sec.	_____	_____	_____
All Call	_____	_____	_____
Speaker LEDs:			
1	_____	_____	_____
2	_____	_____	_____
3	_____	_____	_____
4	_____	_____	_____
5	_____	_____	_____
6	_____	_____	_____
7	_____	_____	_____
8	_____	_____	_____
9	_____	_____	_____
10	_____	_____	_____
Status:			
AC	_____	_____	_____
DC	_____	_____	_____
Partial	_____	_____	_____
Full	_____	_____	_____
Status Request	_____	_____	_____
Intrusion*	_____	_____	_____

***Optional**

Fig. 11: System LED Diagnostic Indicators

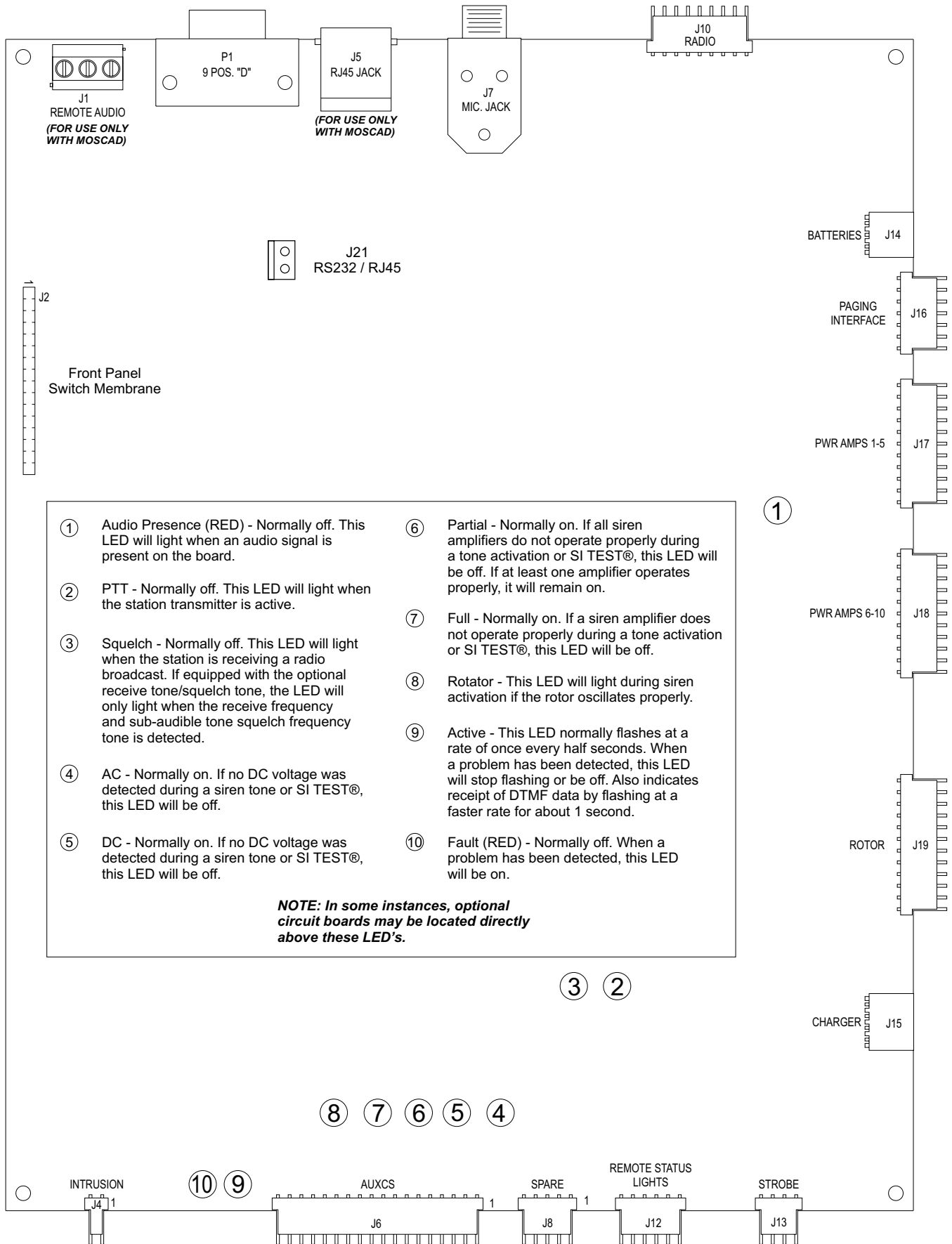

Fig. 12: Control Board Wire Colors

